

Art.-Nr. 440 751, 440 752, 440 753

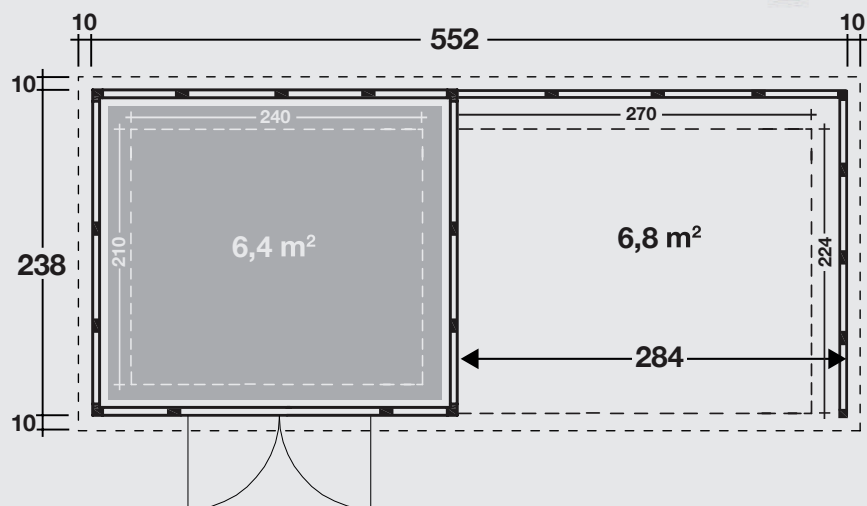

Projet numéro / Project number / Project number / Projekt Nummer :

QC-numéro / QC-nummer / QC-number / QC-Nummer :

Couleur / Kleur / Colour / Farbe:

- Blanc, Wit, White, Weiß
- Gris clair, Licht grijs, Light grey, Lichtgrau
- Anthracite, Antraciet, Anthracite, Granitgrau

- Zubehör**
- Fußboden
 - Innenwand: Innenwandpaket während des Hausaufbaus montieren. Nicht im Nachhinein montierbar!
 - Lochblech
 - Bodenschwelle / Rampe

**DONNÉES TECHNIQUES /
INSTRUCTIONS DE MONTAGE**
**TECHNISCHE GEGEVENS /
MONTAGE HANDLEIDING**
**TECHNICAL DATA /
ASSEMBLY INSTRUCTIONS**
**TECHNISCHE DATEN /
MONTAGEANLEITUNG**



Nous vous invitons à lire attentivement le présent mode d'emploi.
 Vous y trouverez les caractéristiques techniques ainsi que toutes les informations utiles en vue d'un fonctionnement correct.
 Les données techniques figurant dans cette publication peuvent être modifiées à tout moment et sans avis préalable et ce,
 pour des raisons techniques ou commerciales..

Wij nodigen u uit deze handleiding aandachtig te lezen.
 Ze omvat de technische eigenschappen en alle nuttige informatie voor een correcte werking.
 De technische gegevens in deze publicatie kunnen om technische of commerciële redenen op elk moment en zonder
 voorafgaande kennisgeving worden gewijzigd.

Please read this manual carefully.
 It contains the technical properties and all the information required for correct operation.
 The technical data in this publication is subject to change for technical and/or commercial reasons at any time and without notice.

Bitte lesen Sie diese Anleitung sorgfältig durch.
 Sie enthält die technischen Eigenschaften und alle Informationen, die für einen korrekten Betrieb erforderlich sind.
 Die in dieser Publikation enthaltenen technischen Daten können jederzeit ohne Vorankündigung aus technischen oder
 kommerziellen Gründen geändert werden.



Lisez bien l'ensemble du mode d'emploi avant de commencer à réaliser des travaux.

Lees de volledige handleiding voordat u begint met de werken uit te voeren.

Read the entire manual before you start working.

Lesen Sie vor Arbeitsbeginn die gesamte Anleitung.



L'utilisation de gants est obligatoire.

Het gebruik van handschoenen is verplicht.

The use of gloves is mandatory.

Das Tragen von Handschuhen ist Pflicht.



L'utilisation de lunettes de protection est obligatoire.

Het gebruik van een veiligheidsbril is verplicht.

The use of safety glasses is mandatory.

Das Tragen einer Sicherheitsbrille ist Pflicht.



L'utilisation d'un casque de protection est obligatoire.

Het gebruik van een veiligheidshelm is verplicht.

The use of a hard hat is mandatory.

Das Tragen eines Sicherheitshelms ist Pflicht.

Liste d'outils / Gereedschappenlijst / Tools List / Werkzeugliste

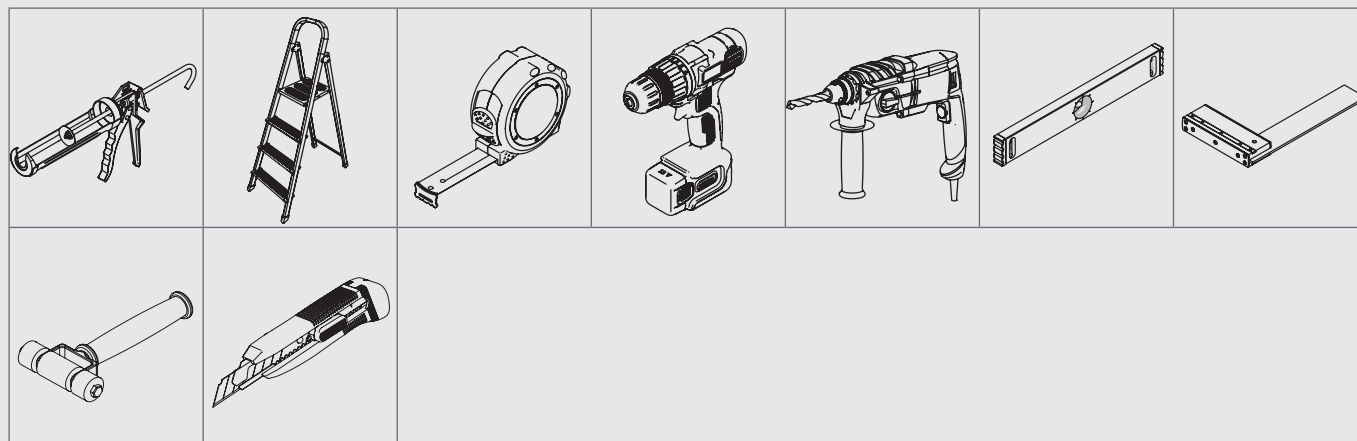

Liste des composants / Stukslijst / Partslist / Teileliste

A27 1x 	A24 1x 	A21 3x 	AD24 1x 	B6 31x 	F6 10x 	FA6 1x
FPH1 1x 	FPH2 2x 	FTPPH 1x 	HA6 4x L= 2080mm 	HPH 1x L= 2064mm 	FD18 1x 	UD18 1x
KT18 1x 	K6R 1x 	K6LD 1x 	K6S 6x 	J24R 1x 	J27 1x 	J24 1x
J21 3x 	J21S 3x 	JDA27 1x 	JDA24 1x 	JD24 1x 	Z24A 1x 	Z21B 1x
Z24C1 1x 	Z24C2 1x 	Z21D 1x 	AB-5 5x AB-1,25 1x 	ZAPHR 1x 	ZAV 1x 	DA030 12x
DA27 12x 	DA24 6x 	DA21 22x 	DAVL21 1x 	DAVR21 1x 	DI030 12x 	DI21 10x
DI24 6x 	DIVR21 1x 	DIVL21 1x 	X24A 1x 	X21B 1x 	X24C 1x 	X21D 1x
IG 2x L= 2.090mm 	IK 2x L= 2.070mm 	TP2724 3x 	BF21 7x 	PP21 1x 	OS18 1x 	

option / optie / option / Option

Liste des composants / Stukslijst / Partslist / Teileliste

ZC1PHR 1x 	ZC2PHR 1x 	ZCVR 1x 	CP01 3x 	CP02 8x 	CP03 3x 	CP05 13x
SD18 600x 	SD18BL 40x 	SD16D 18x 	SD25 2x 	TOOL1 1x 	TOOL2 3x 	TOOL3 1x
RK1 ● 1x RK2 ● RK3 ● 	W1 1x 	W2 1x 	W3 1x 	W4 2x 	M27 1x 	M24 2x
M21 3x 	DK 1x 	SPB6 4x 	BZ 16x 	DR 1x 	DL 1x 	2724PHR-1 1x
2724PHR-2 1x 	2724PHR-3 1x 	2724PHR-4 1x 	2724PHR-5 1x 	S6PH 2x 2 	XPHA 1x 	XPHB 1x
XPHC 13x 	XPHR 3x 	IPHK 2x 	IPHL 1x 	SSP 1x 		



Fundament

- Le sol doit être plat et de niveau. Le sol doit être réalisé pour permettre une fixation adéquate de l'abris de jardin.
- De vloer moet vlak en waterpas zijn. De vloer moet gemaakt worden zodat de bevestiging van het tuinhuis wel mogelijk is.
- The floor must be flat and level. The floor must be made in such a way that it is possible to fix the garden house.
- Der Aufbauort muss eine flache, geschlossene und in Waage liegende Bodenplatte aufzeigen. Die Bodenplatte muss so beschaffen sein, das eine mechanische Befestigung von dem Haus erfolgen kann.

PS

- L'abris de jardin doit être centrée sur la dalle de béton.
- Het tuinhuis moet gecentreerd geplaatst worden op het fundament.
- The garden house must be centered on the foundation.
- Das Gartenhaus muss auf dem Fundament zentriert sein.

Tous les éléments / Alle elementen / All elements / Alle Elemente

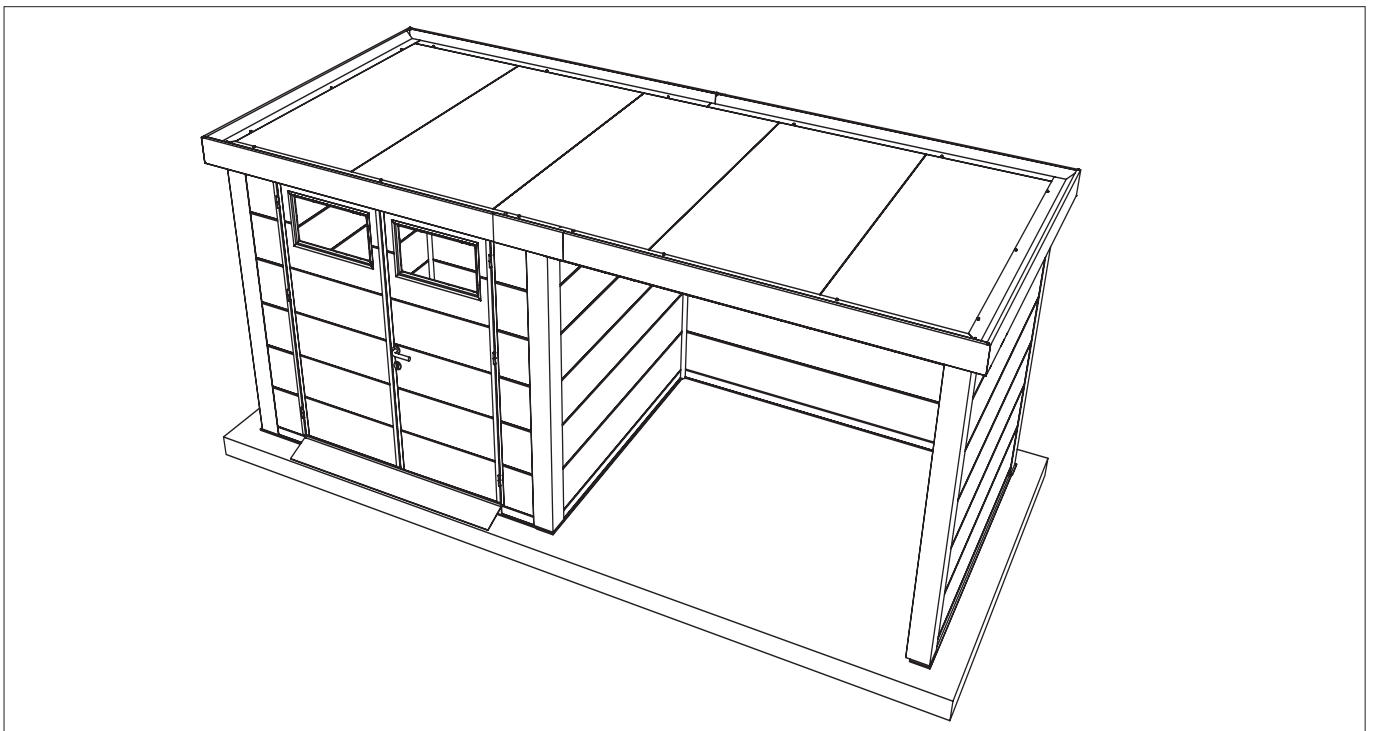

Composition / Compositie / Composition / Zusammensetzung

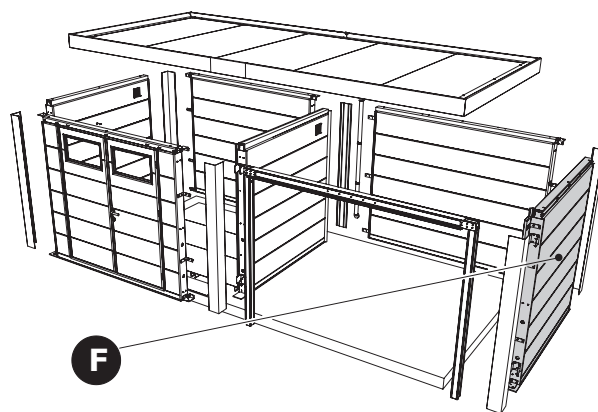
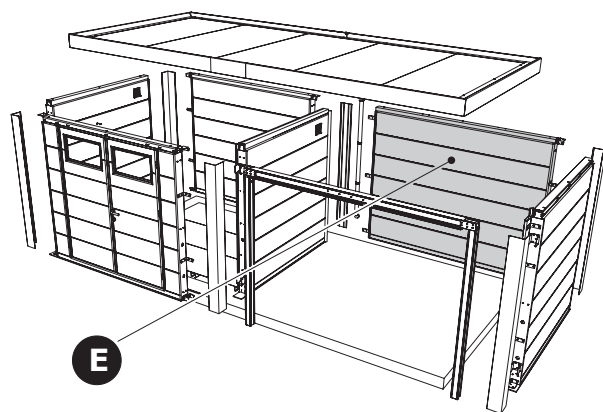
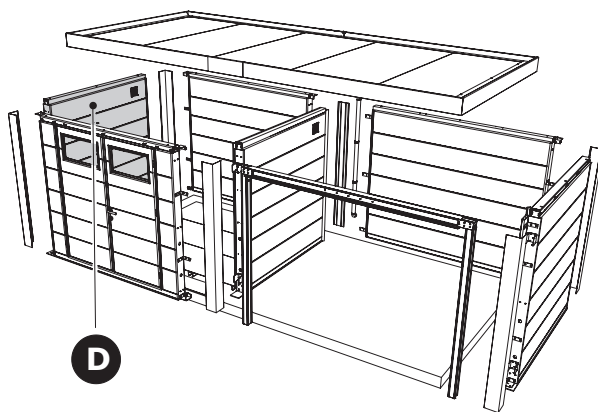
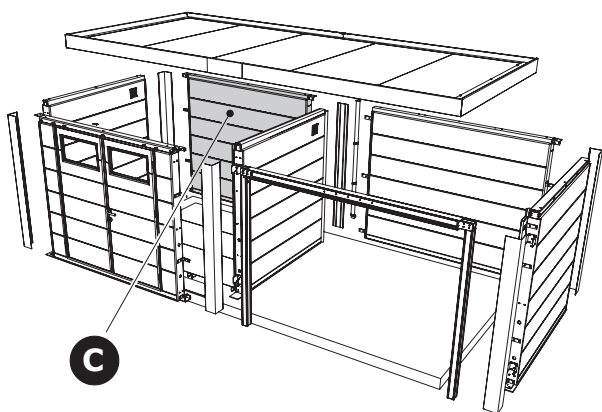
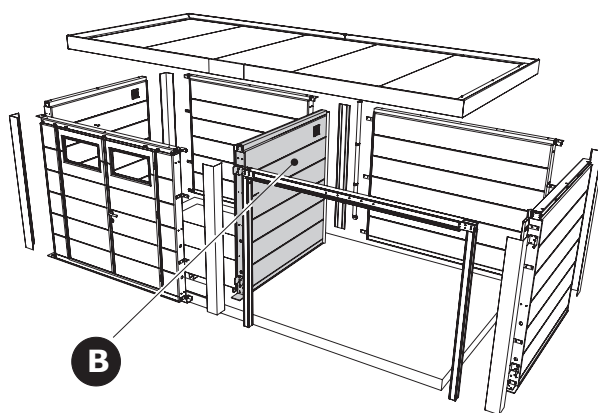
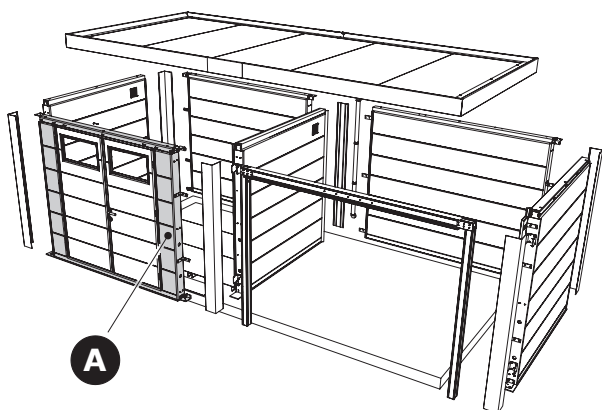
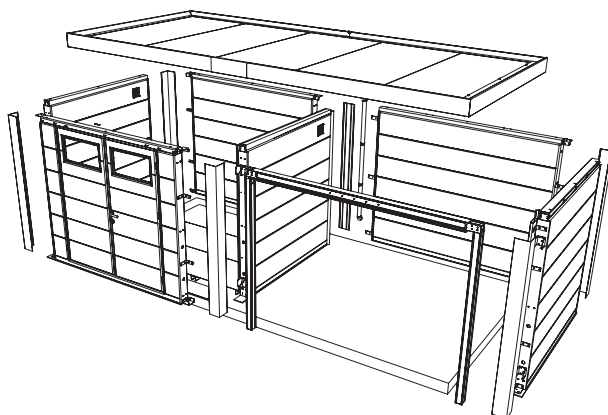

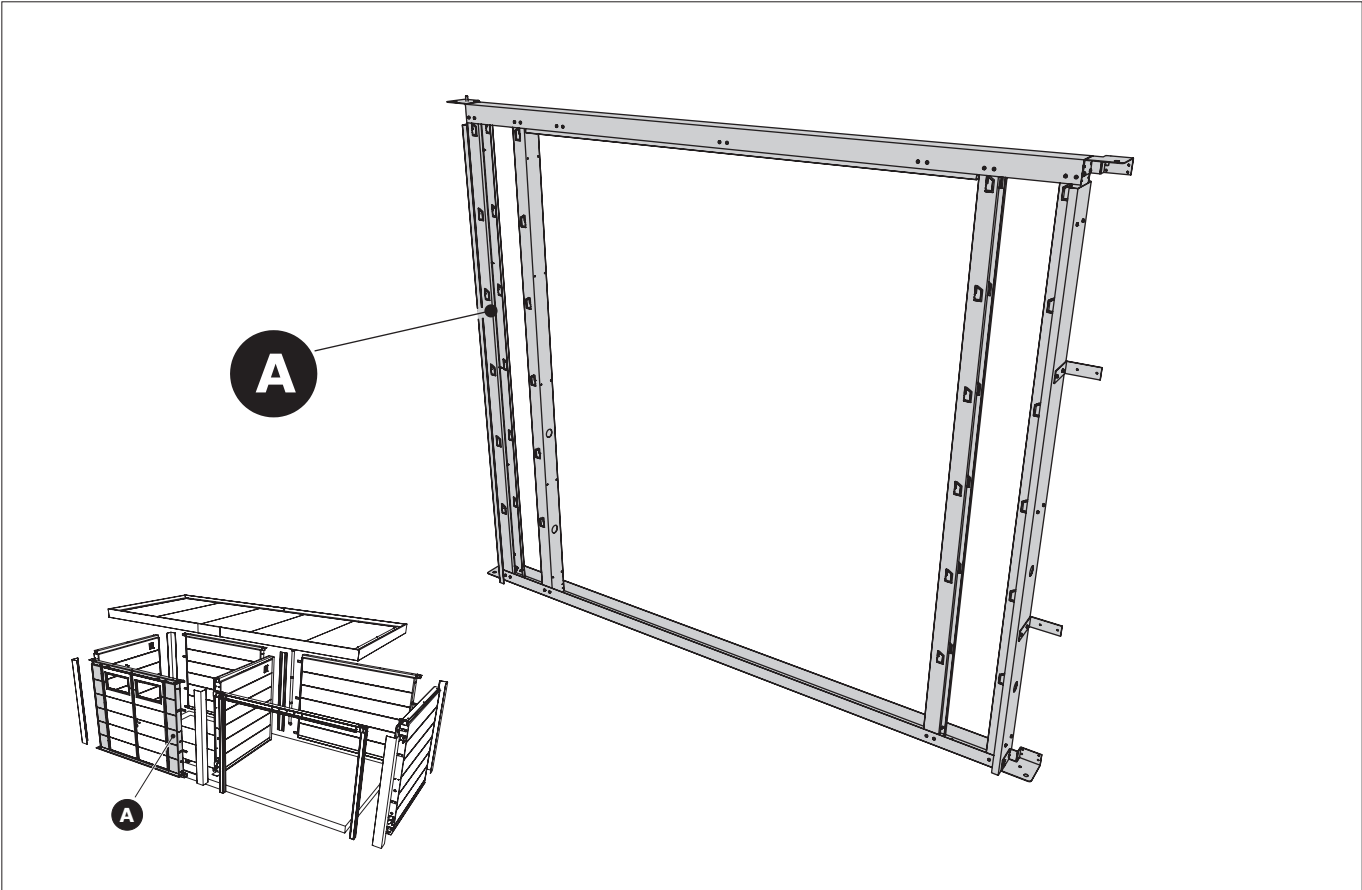

A Paroi / Wand / Wall / Wand

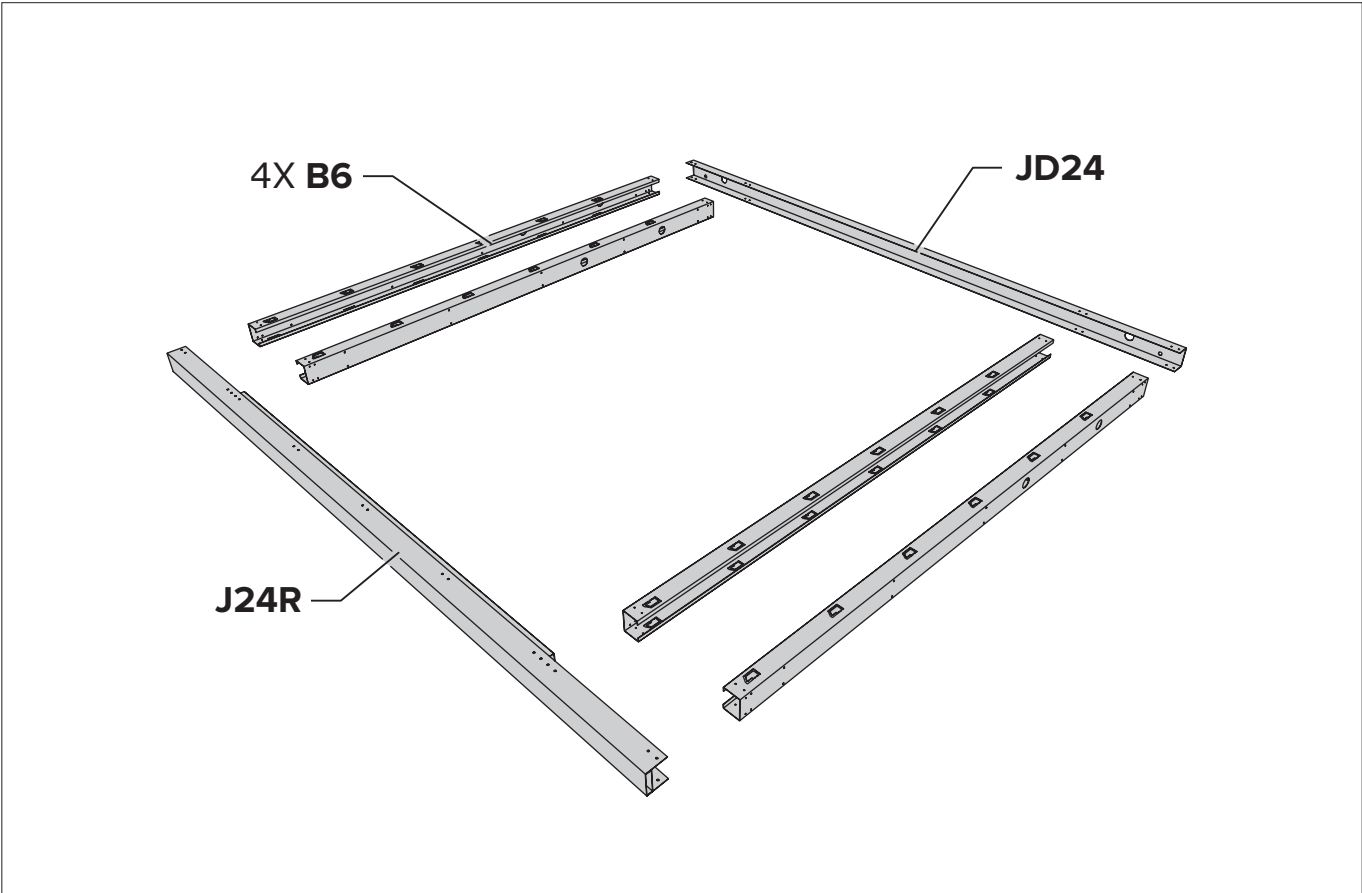

A Paroi / Wand / Wall / Wand

Le principe de la construction du mur (POW).
Het principe van de opbouw van de wand (POW).
The principle of building the wall (POW).
Das Prinzip des Baus der Mauer finden (POW).

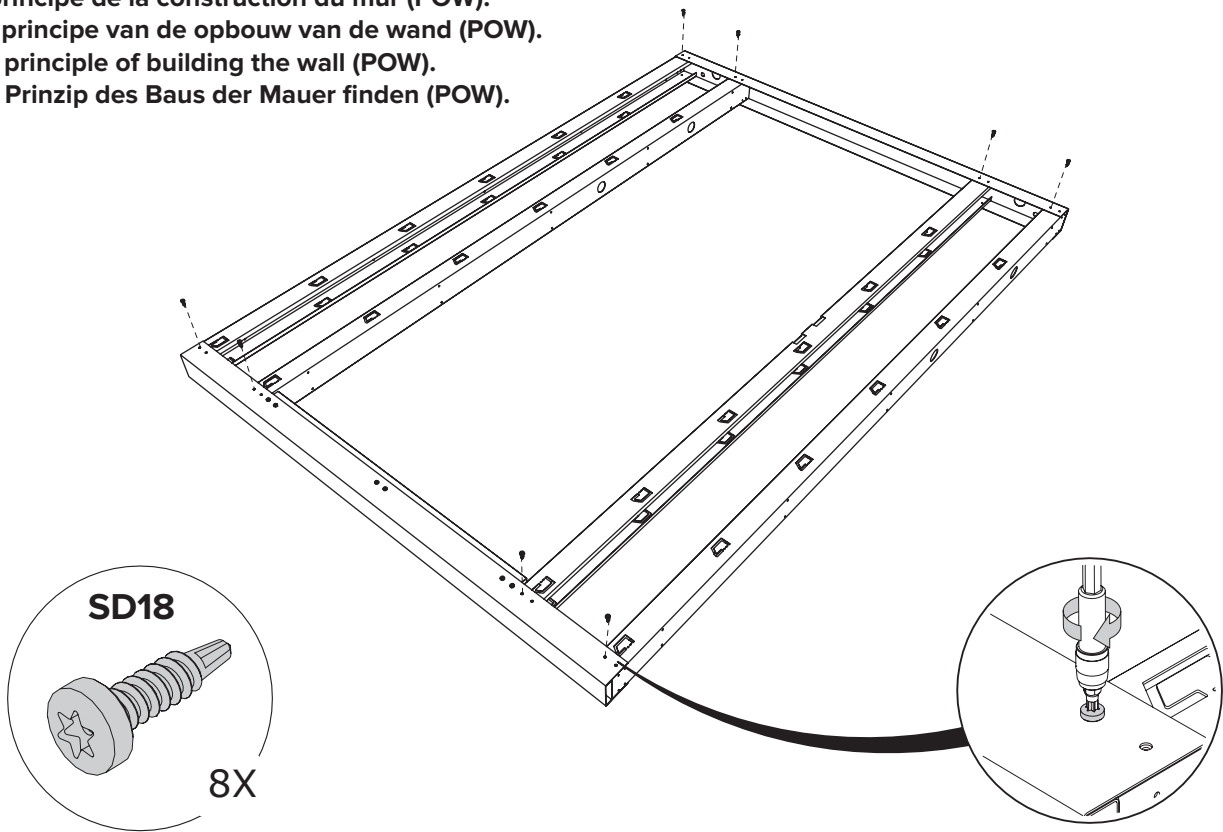

A

Paroi / Wand / Wall / Wand

POW

Tourner encadrement / Kader omdraaien / Turn Frame / Rahmen umdrehen

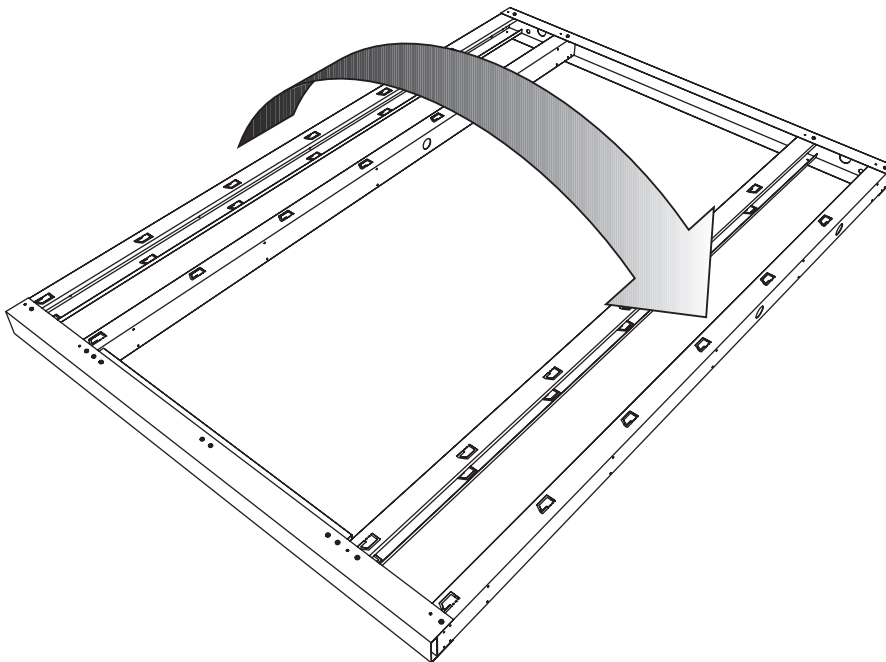

A

Paroi / Wand / Wall / Wand

POW

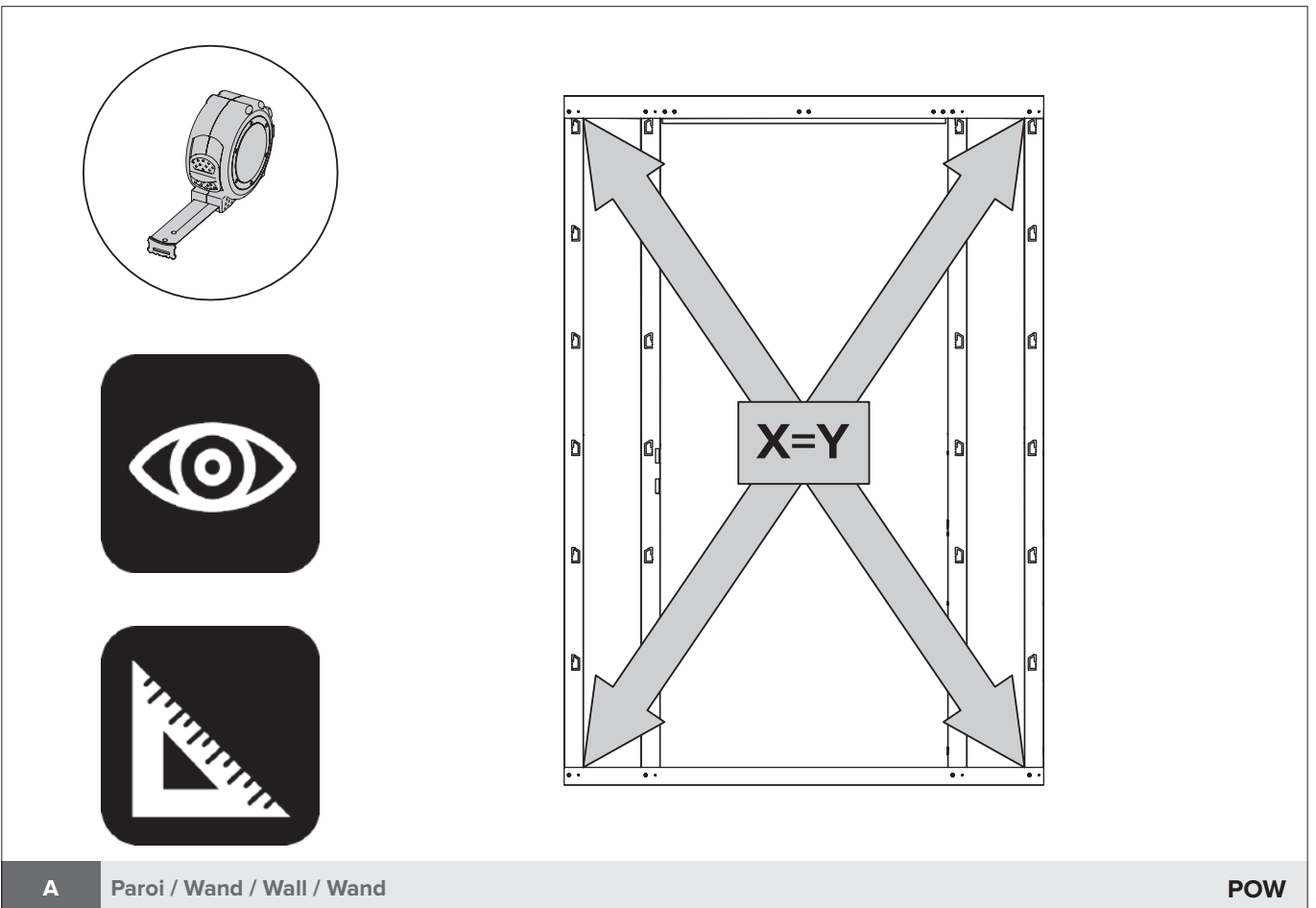
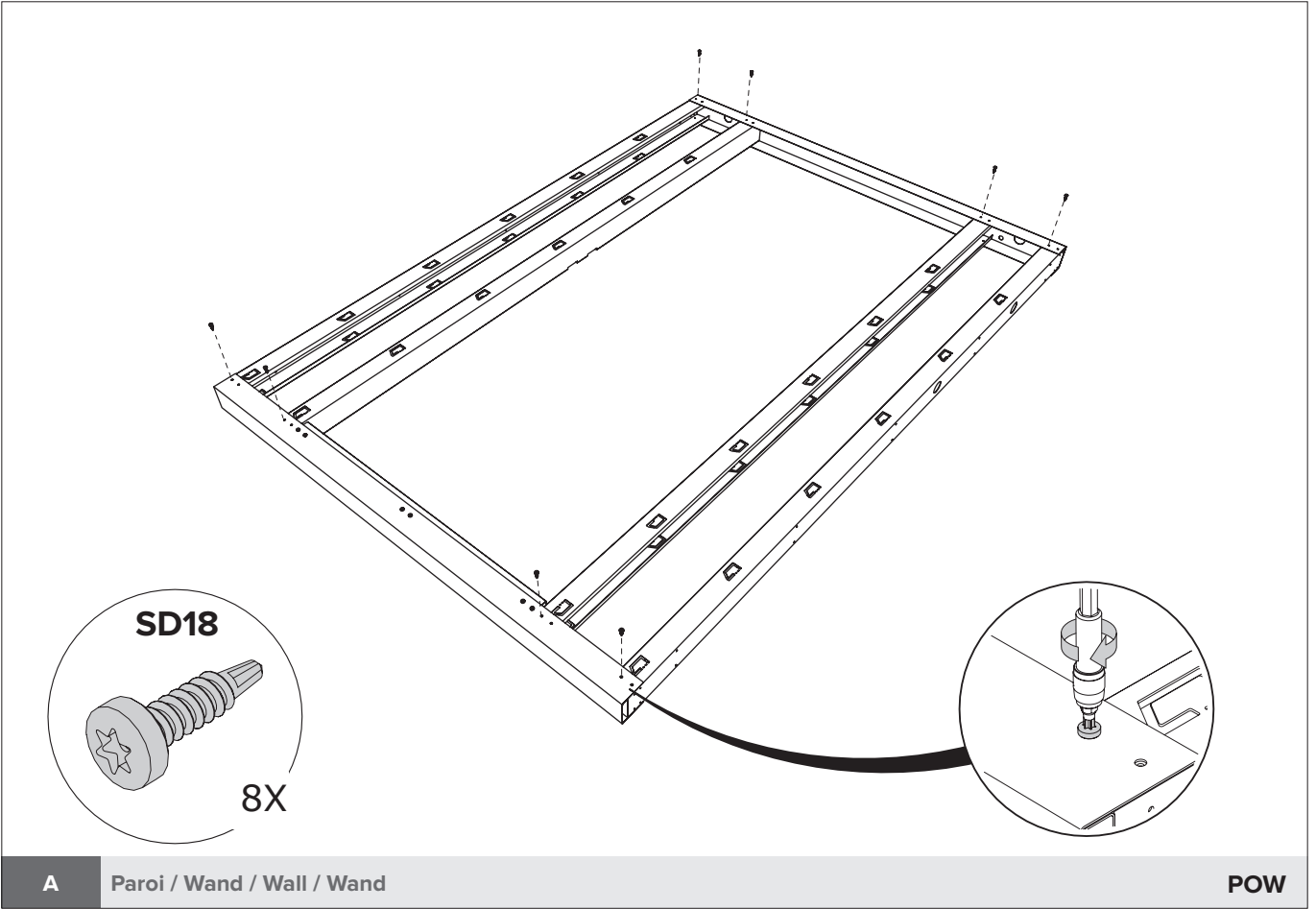

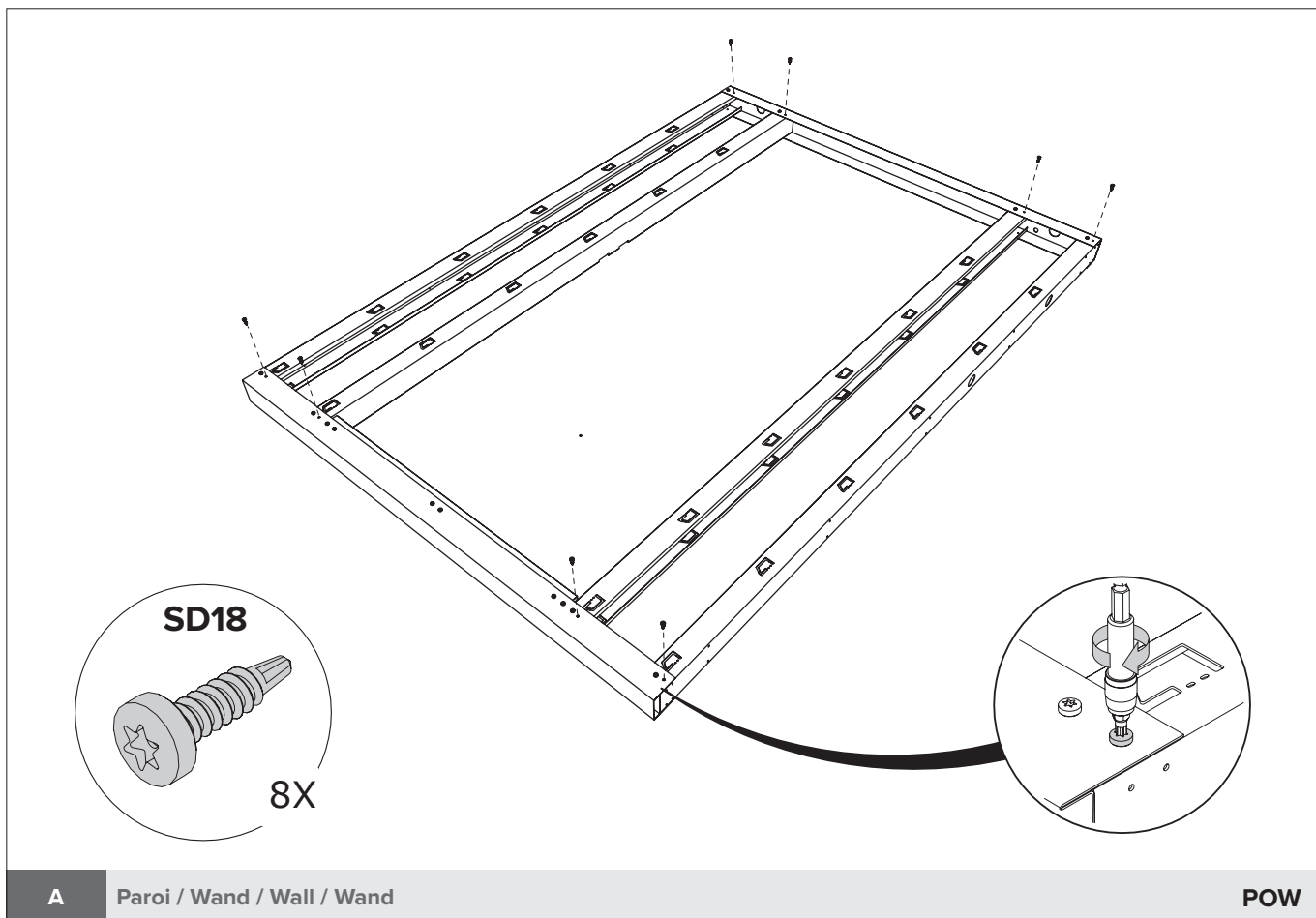

Tourner encadrement / Kader omdraaien / Turn Frame / Rahmen umdrehen

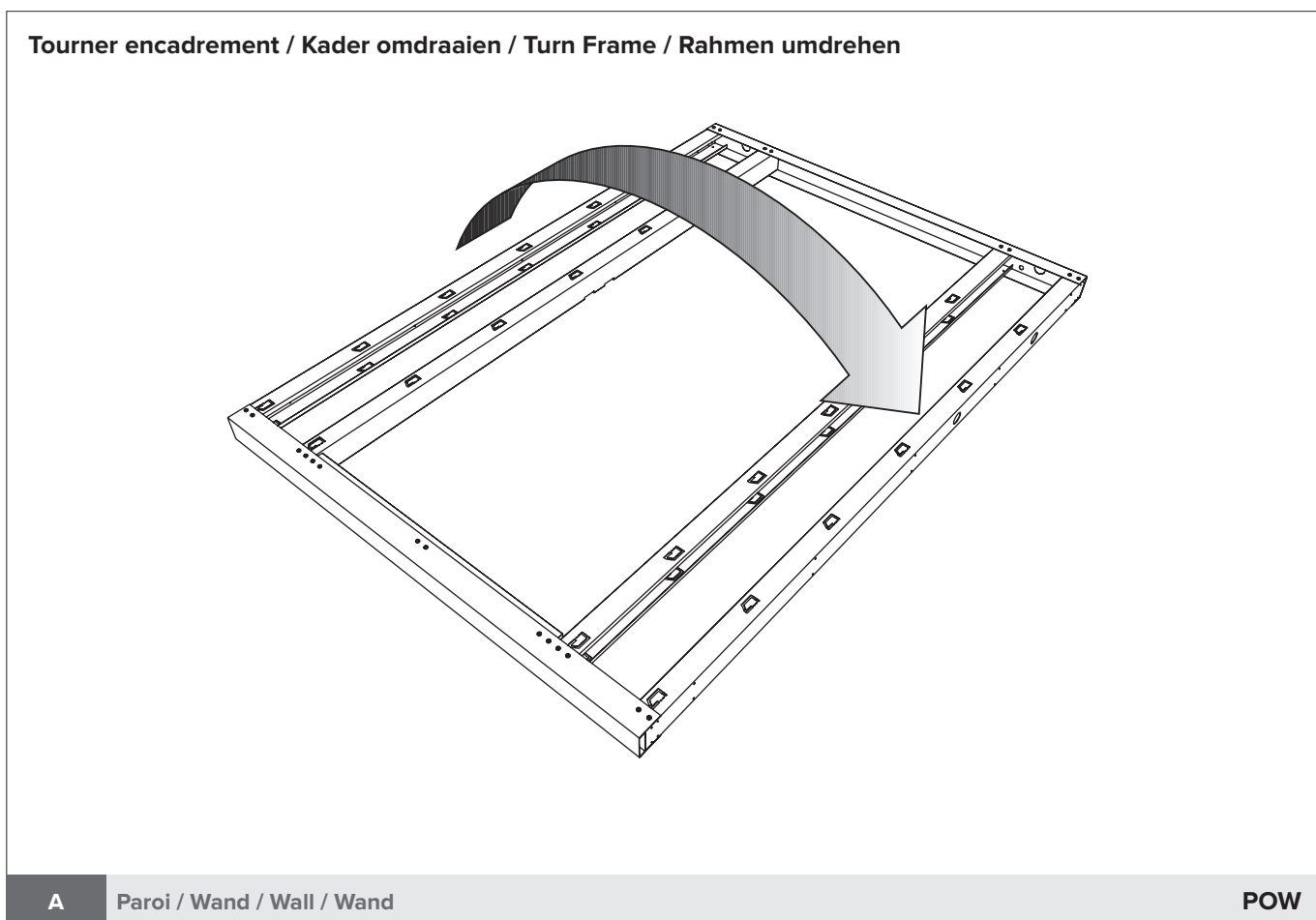

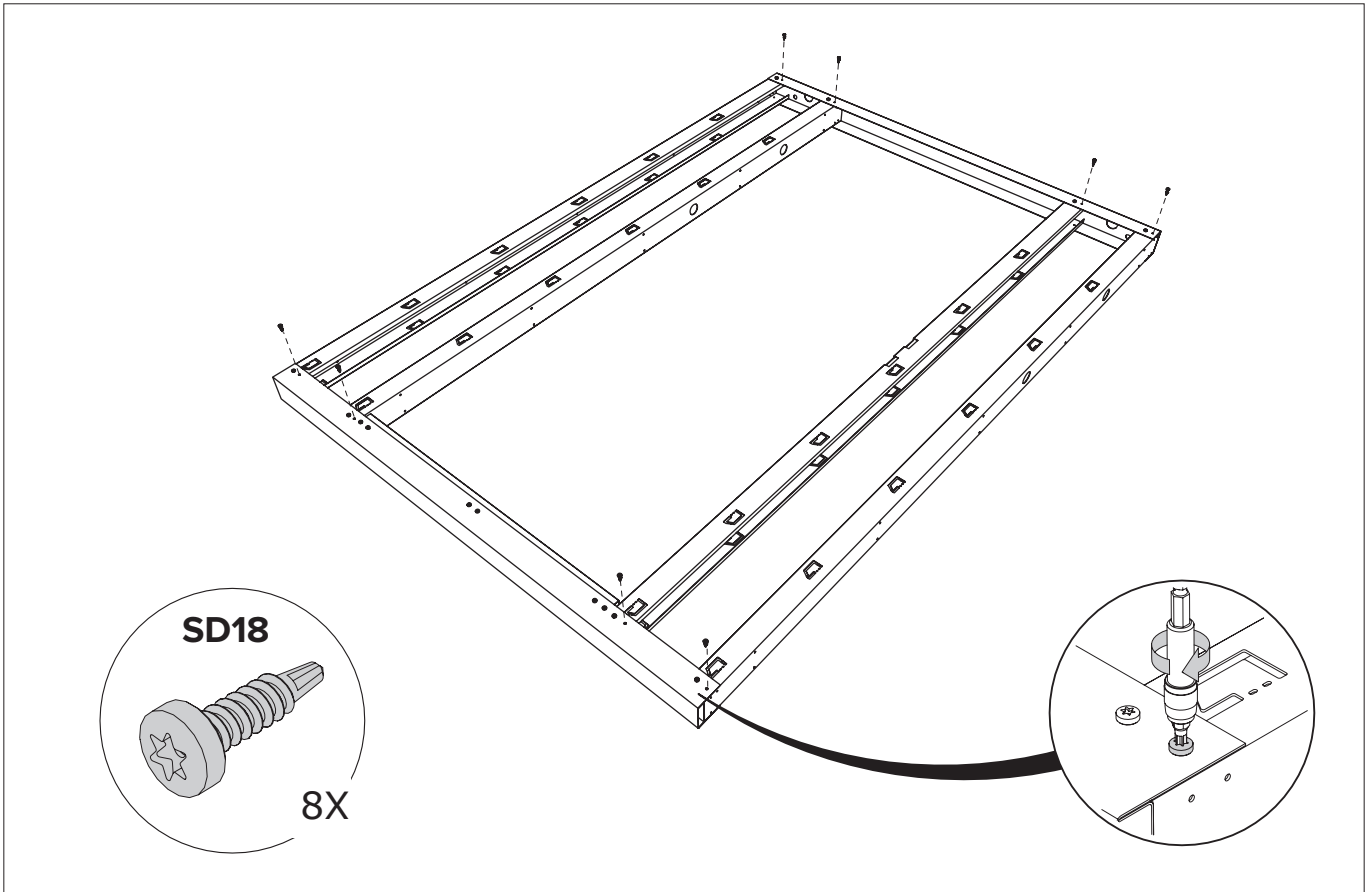

A Paroi / Wand / Wall / Wand POW

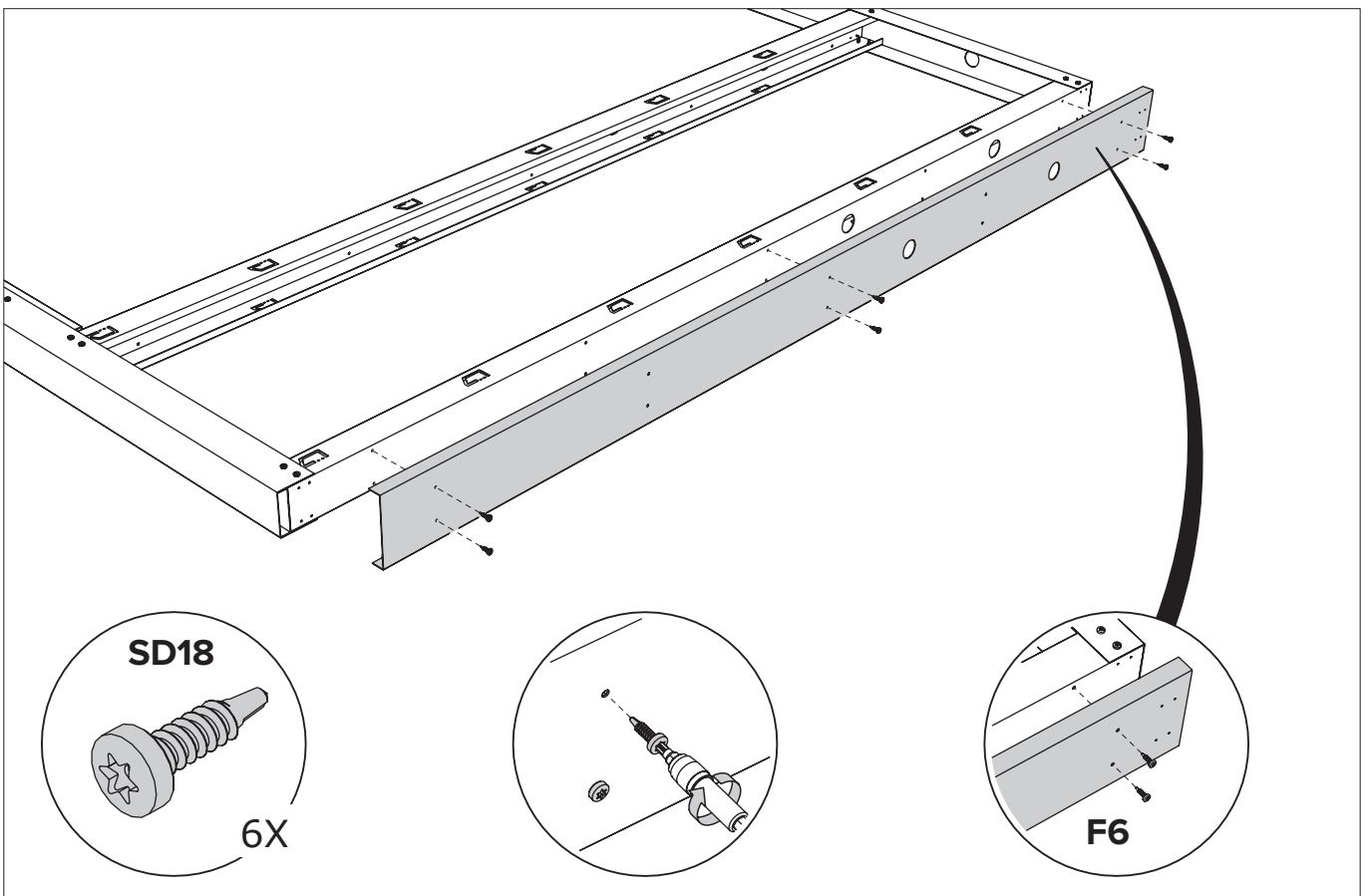

A Paroi / Wand / Wall / Wand

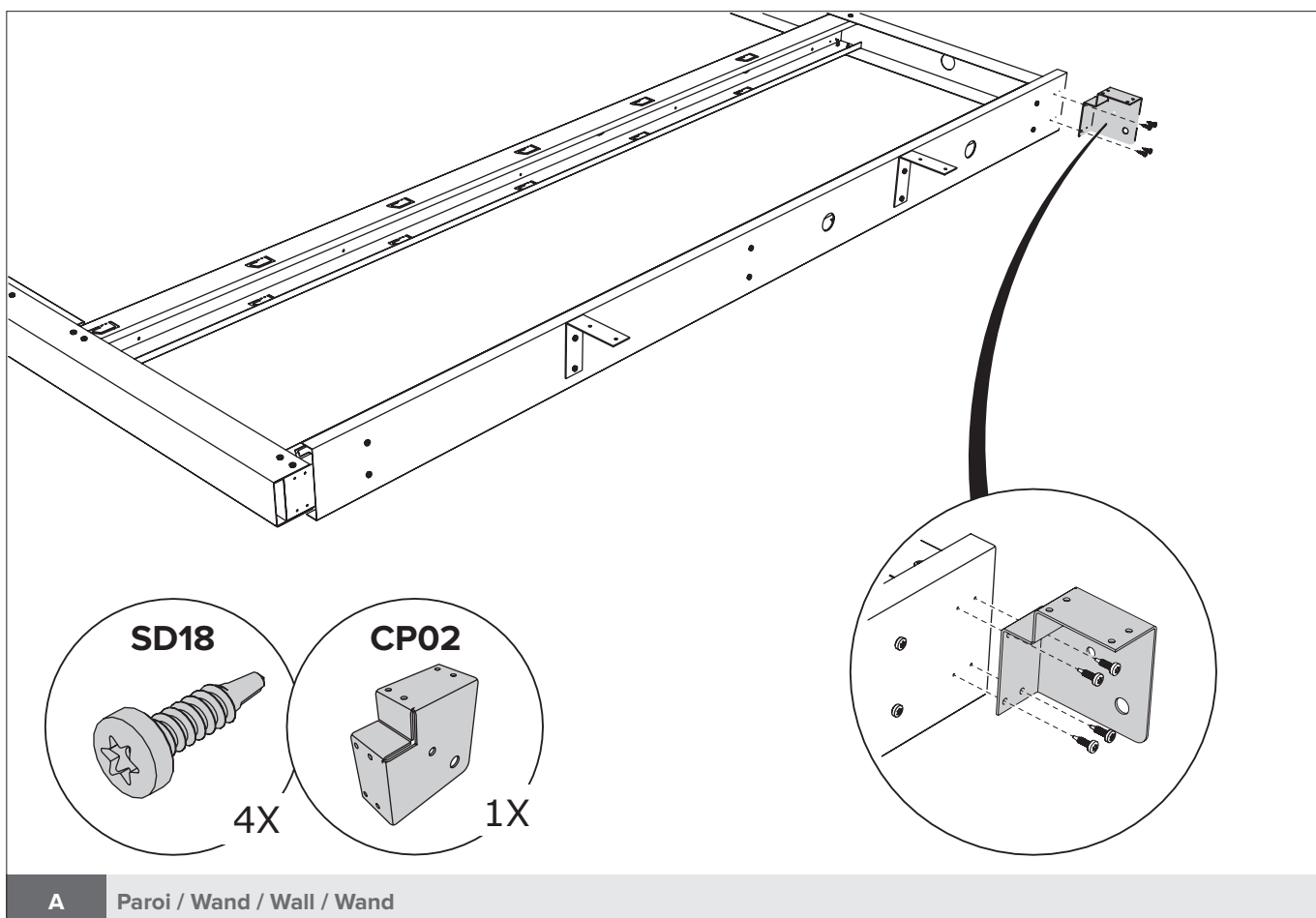
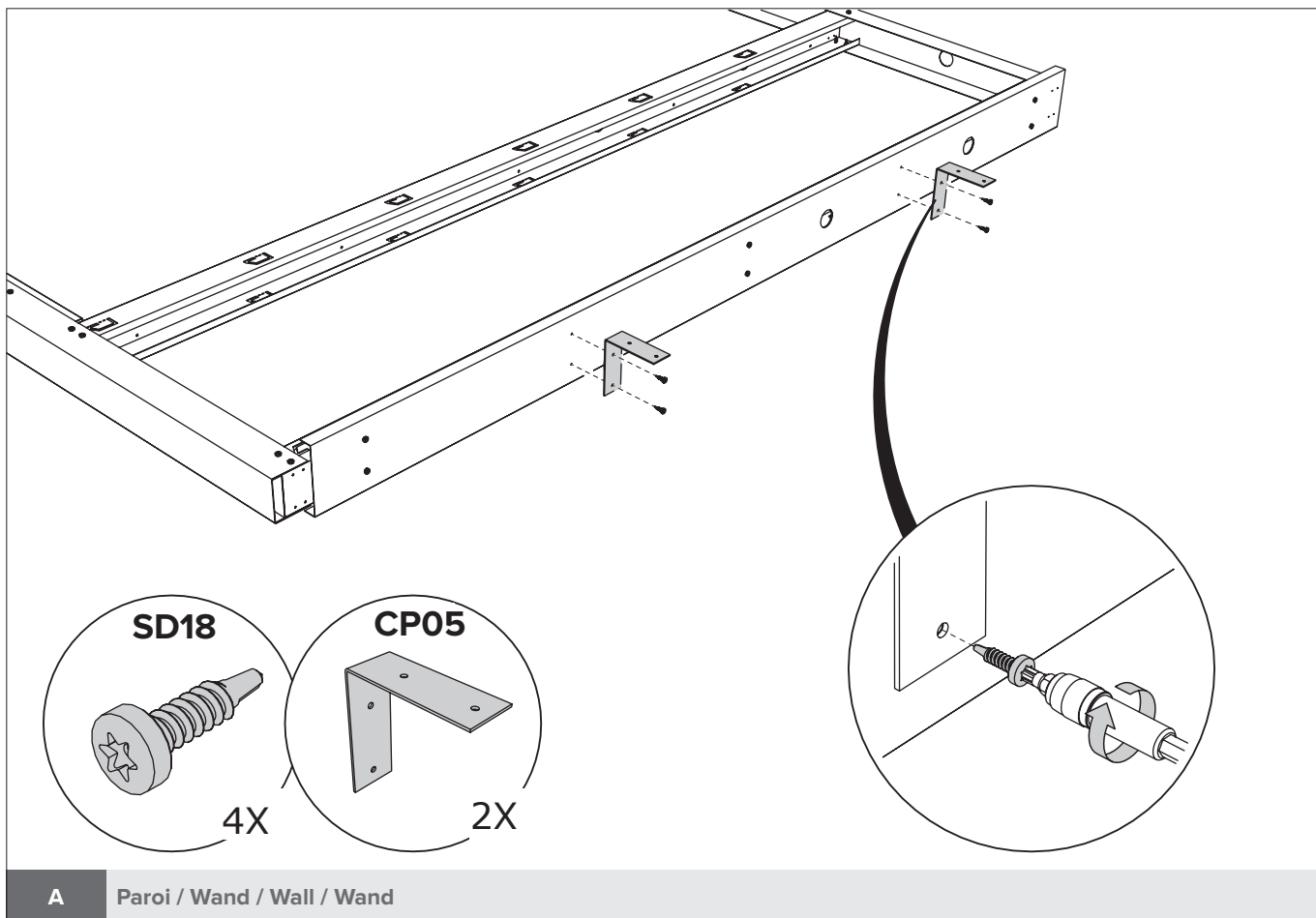

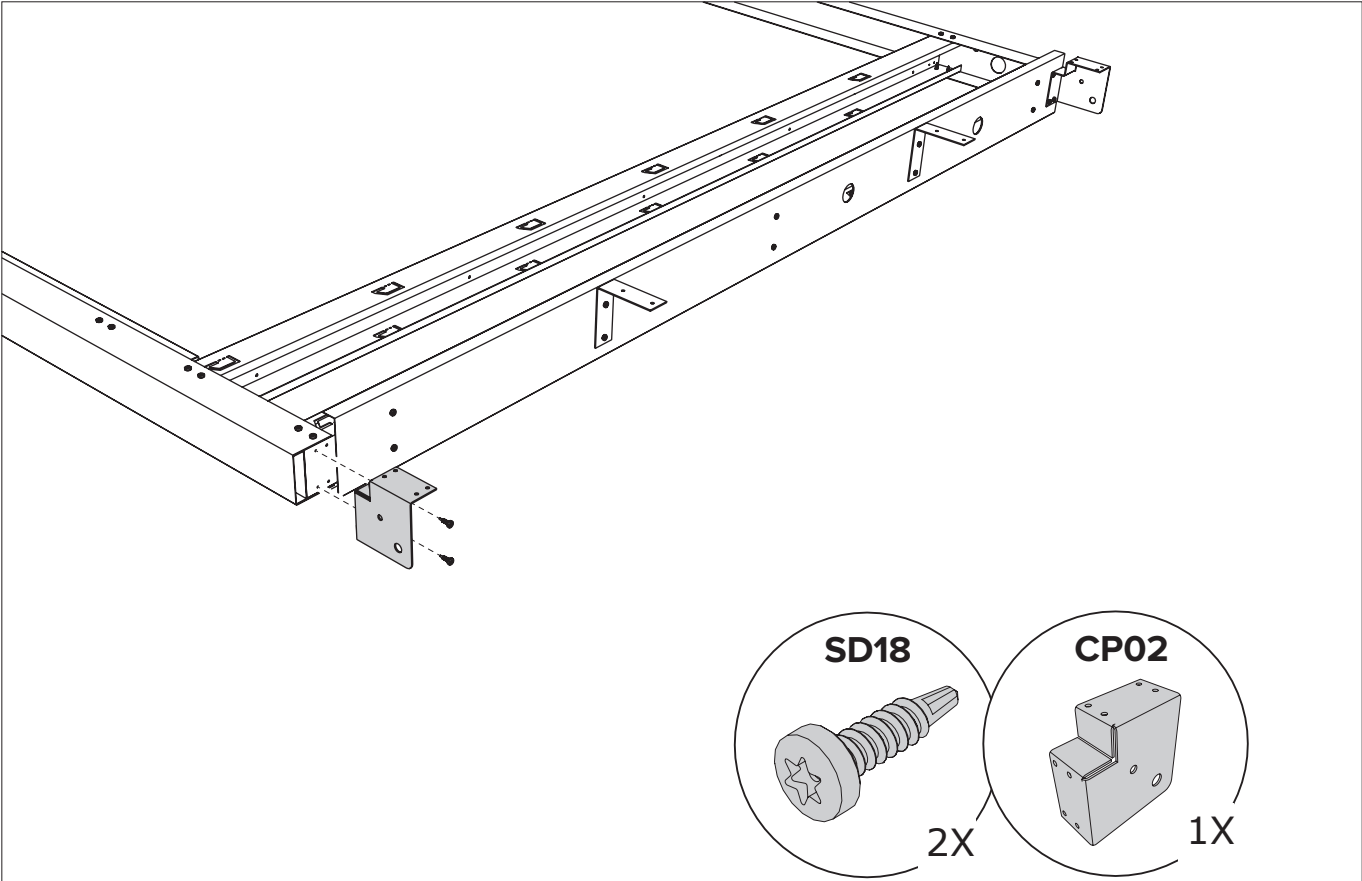

A Paroi / Wand / Wall / Wand

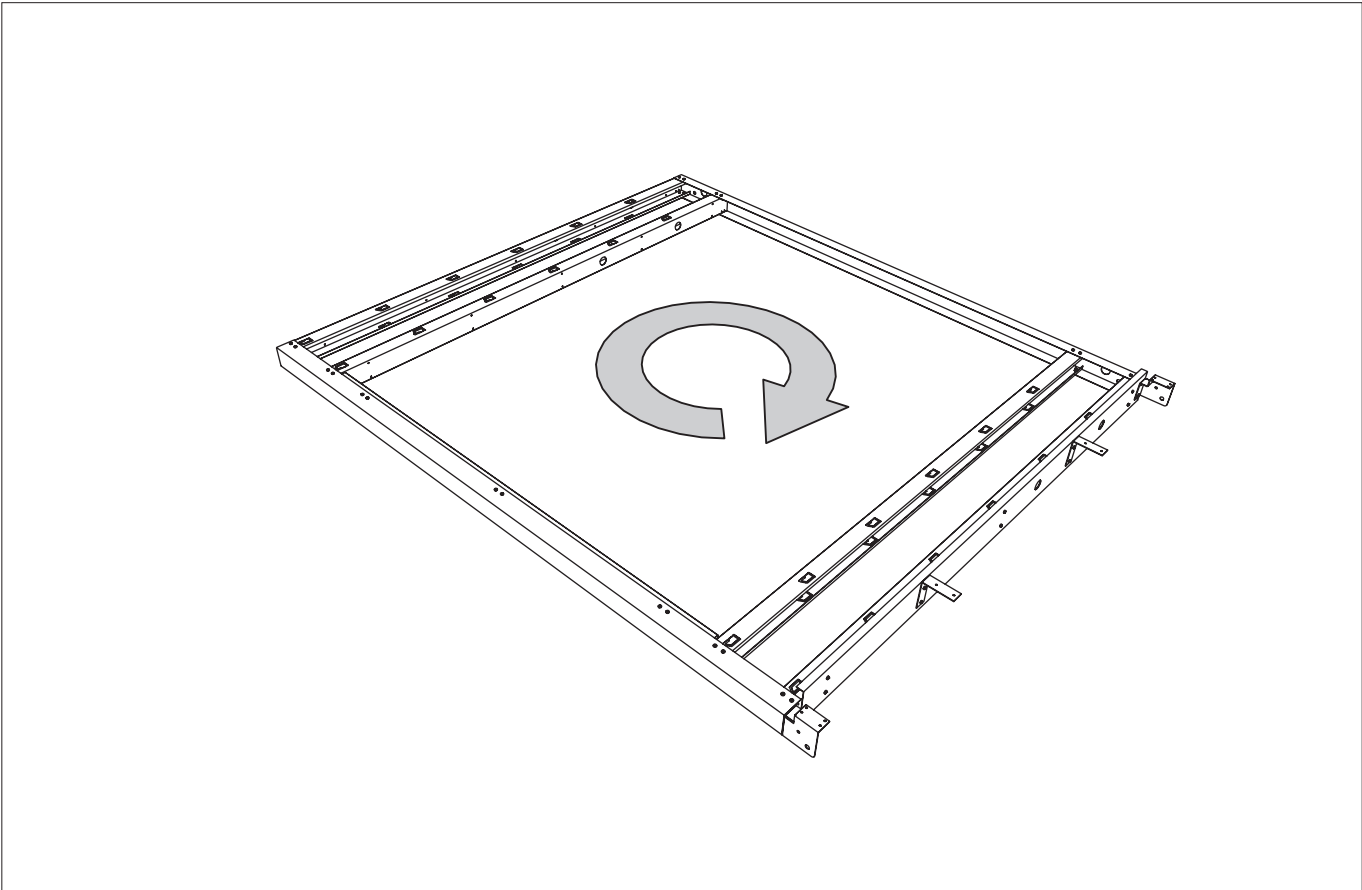

A Paroi / Wand / Wall / Wand

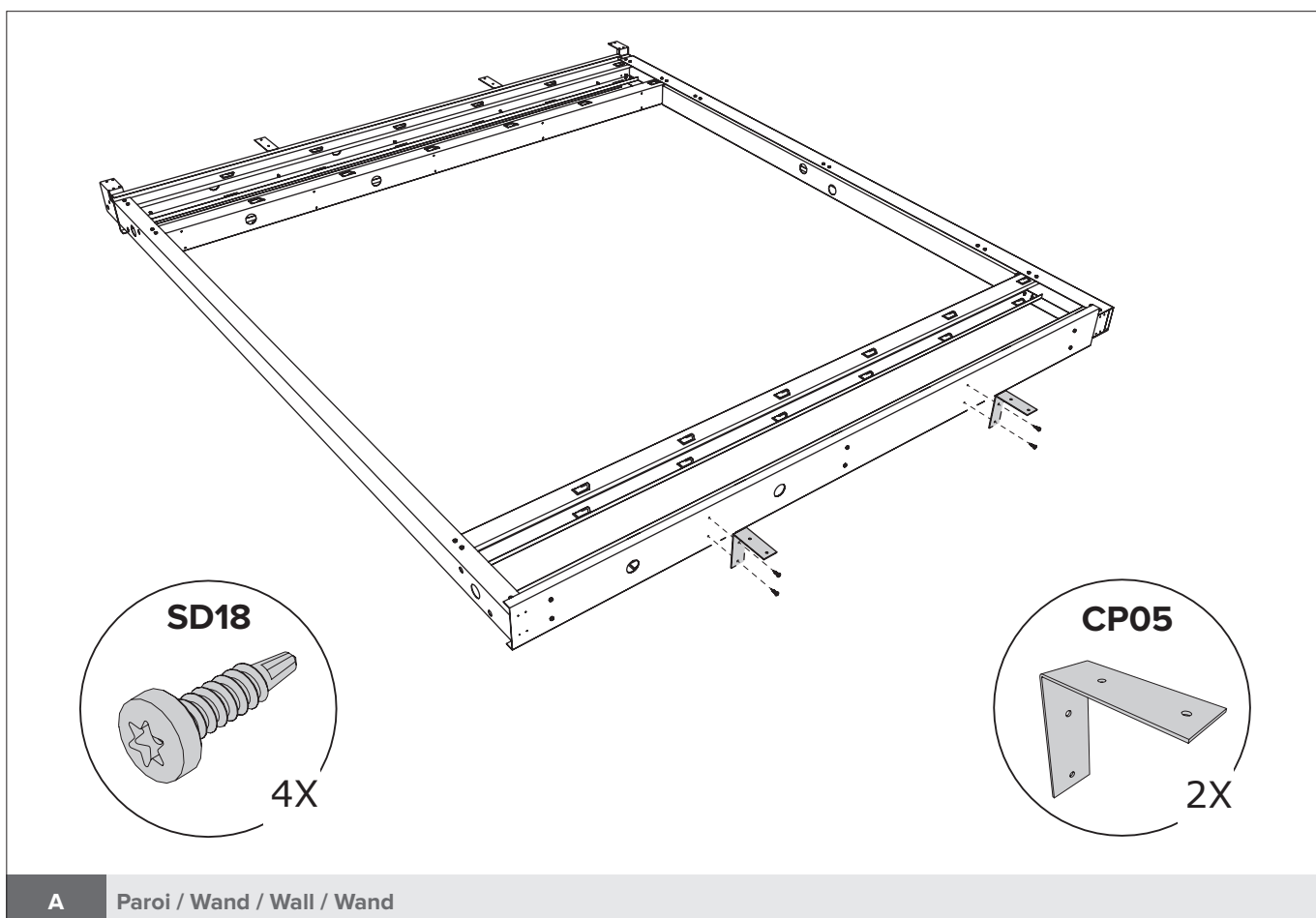
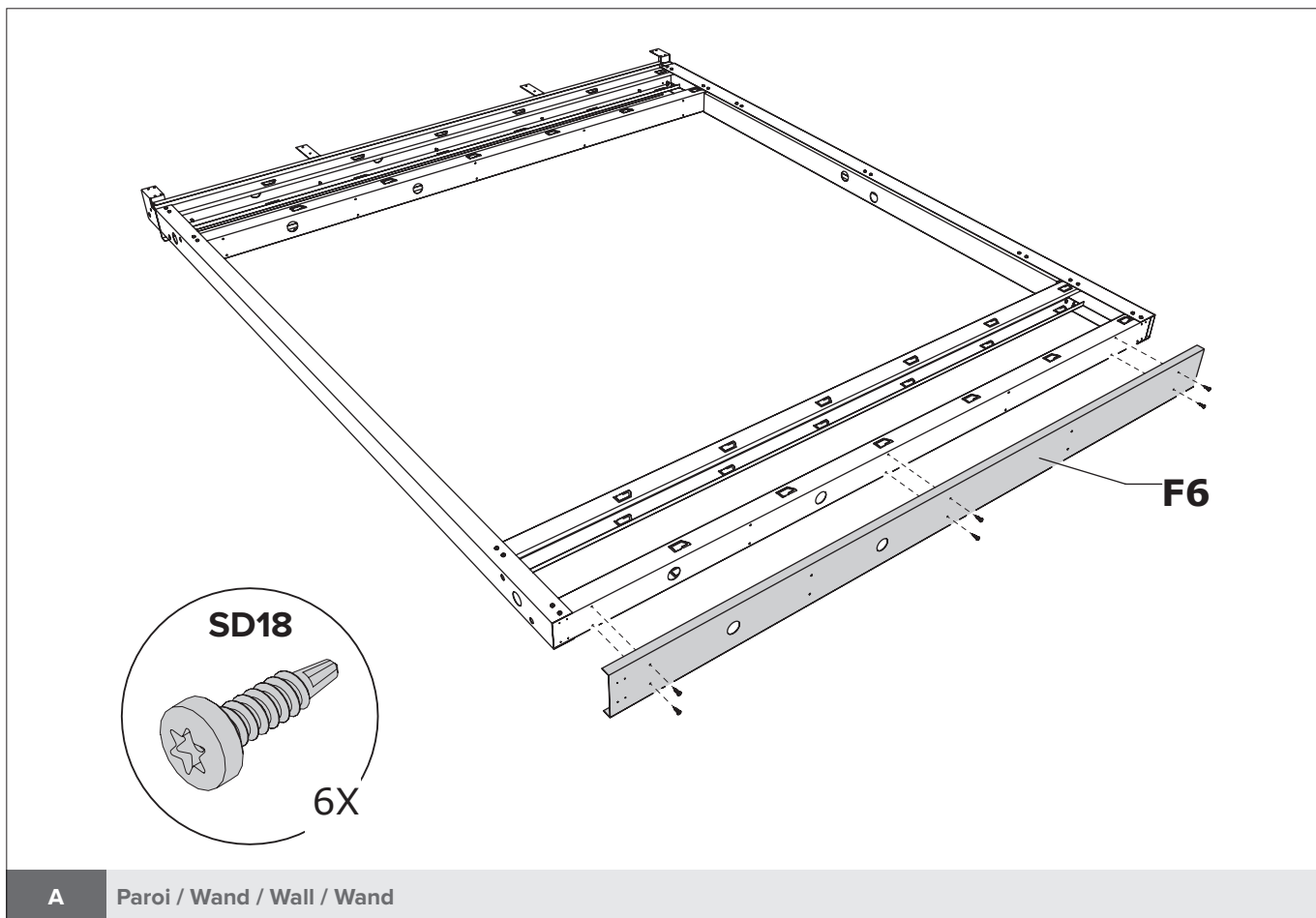

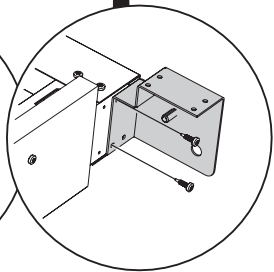
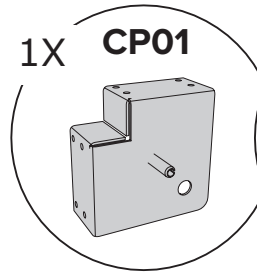
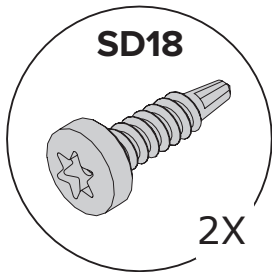
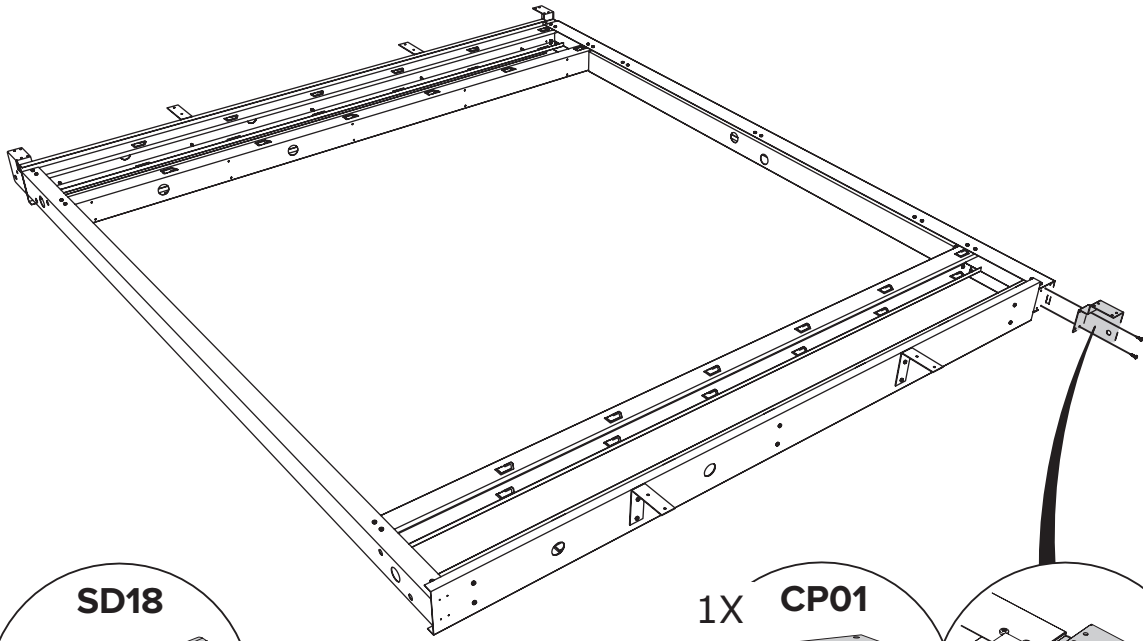

A Paroi / Wand / Wall / Wand

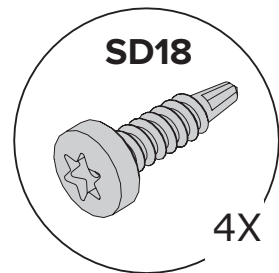
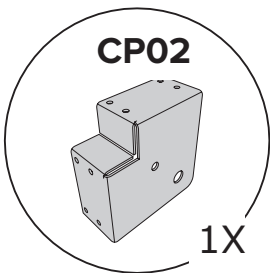
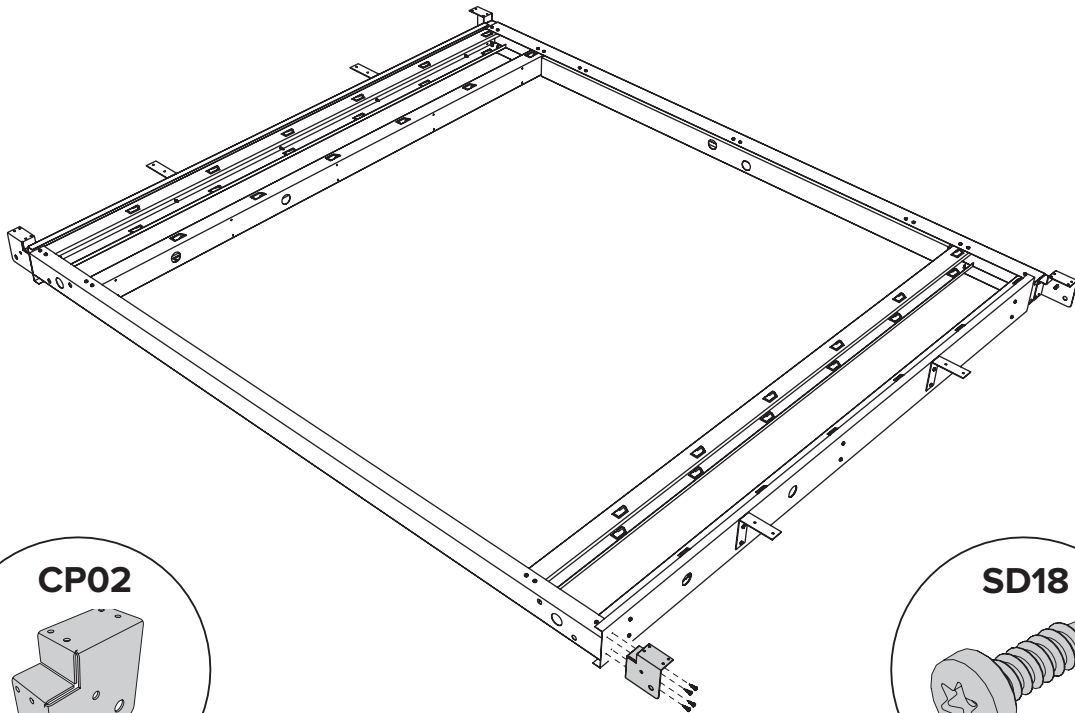

A Paroi / Wand / Wall / Wand

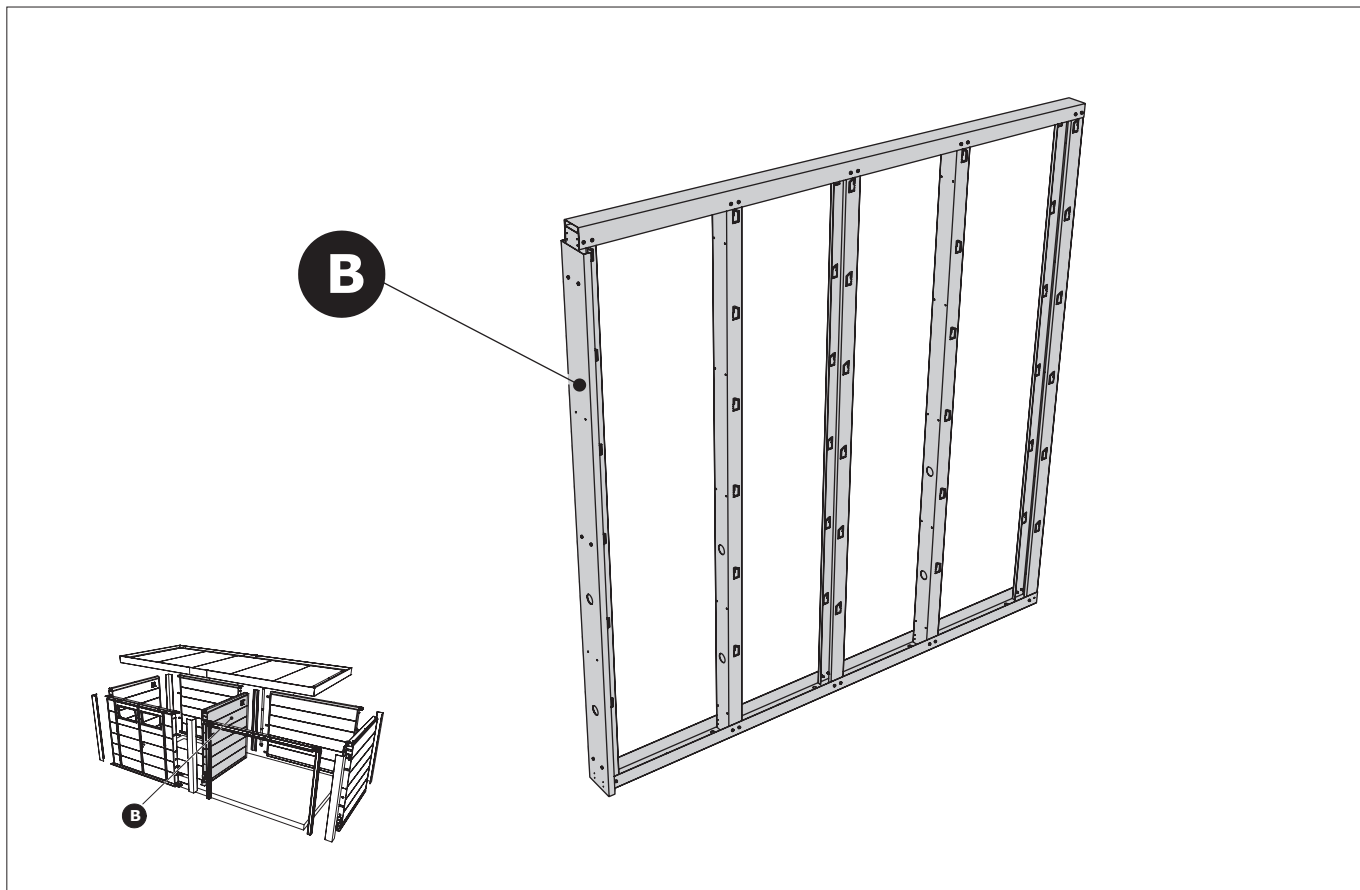

B Paroi / Wand / Wall / Wand

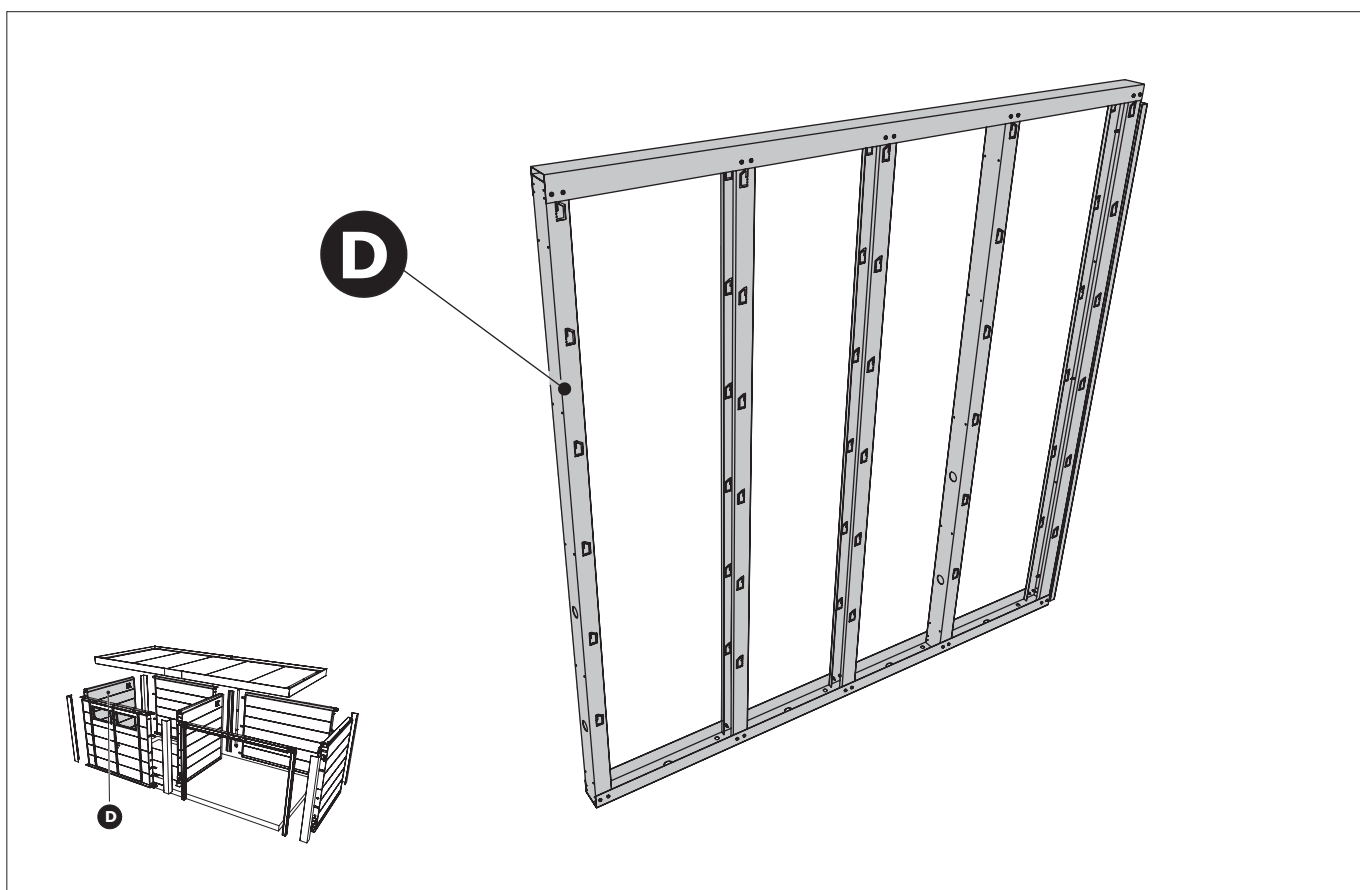

D Paroi / Wand / Wall / Wand

Le principe de la construction du mur, voir pages 8 à 11 (POW).
 Het principe van de opbouw van de wand, zie pagina 8 tot en met 11 (POW).
 The principle of building the wall, see pages 8 through 11 (POW).
 Das Prinzip des Baus der Mauer finden Sie auf den Seiten 8 bis 11 (POW).

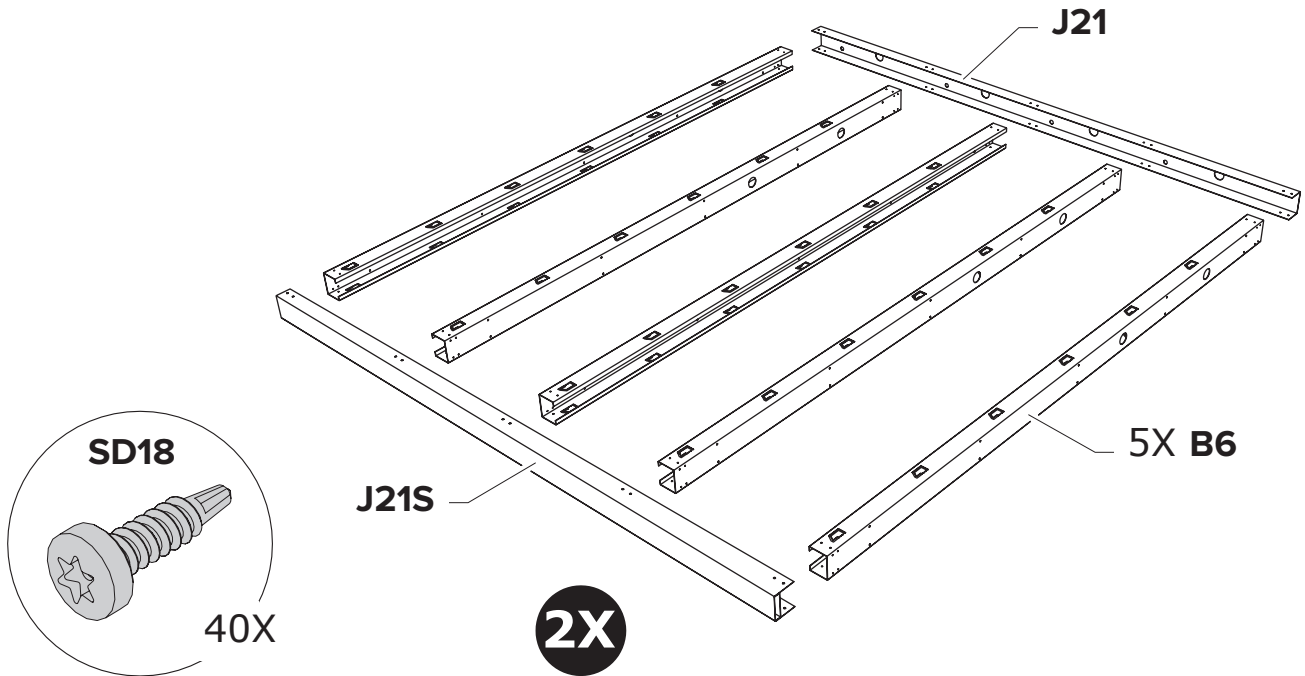

B / D Paroi / Wand / Wall / Wand

B

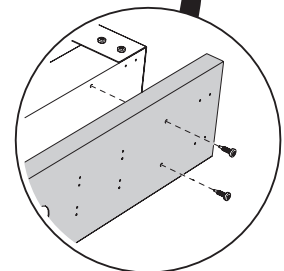
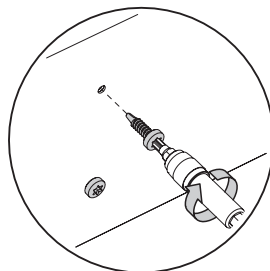
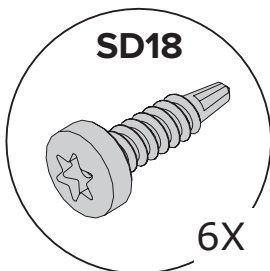
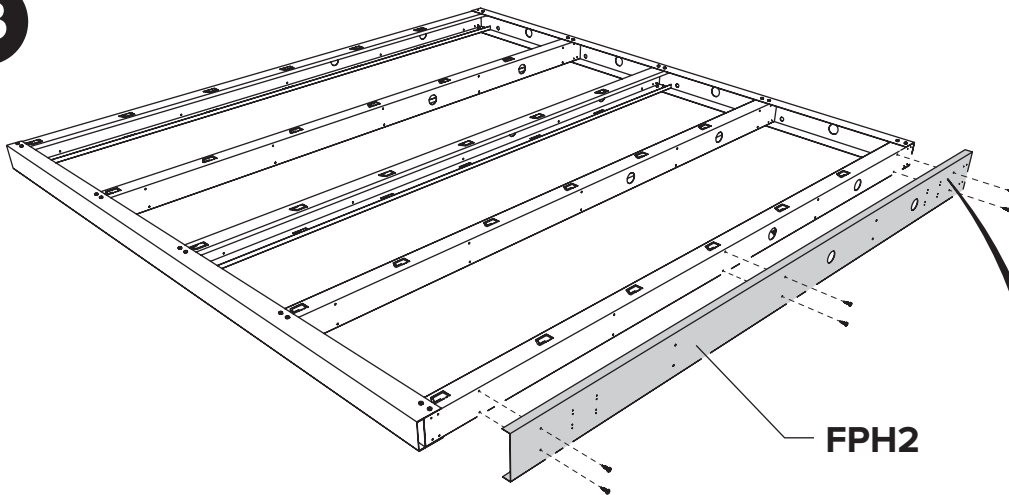

B Paroi / Wand / Wall / Wand

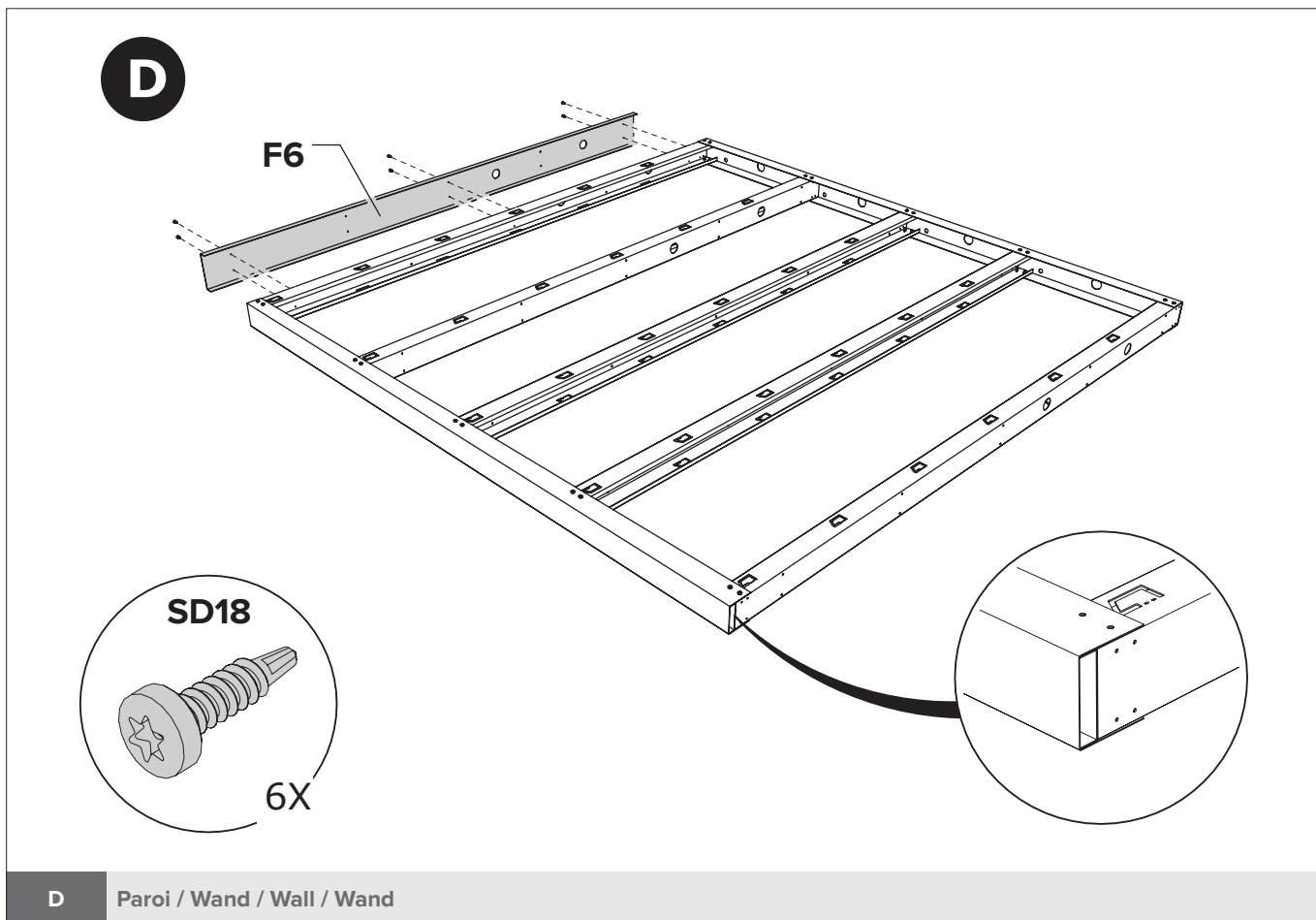

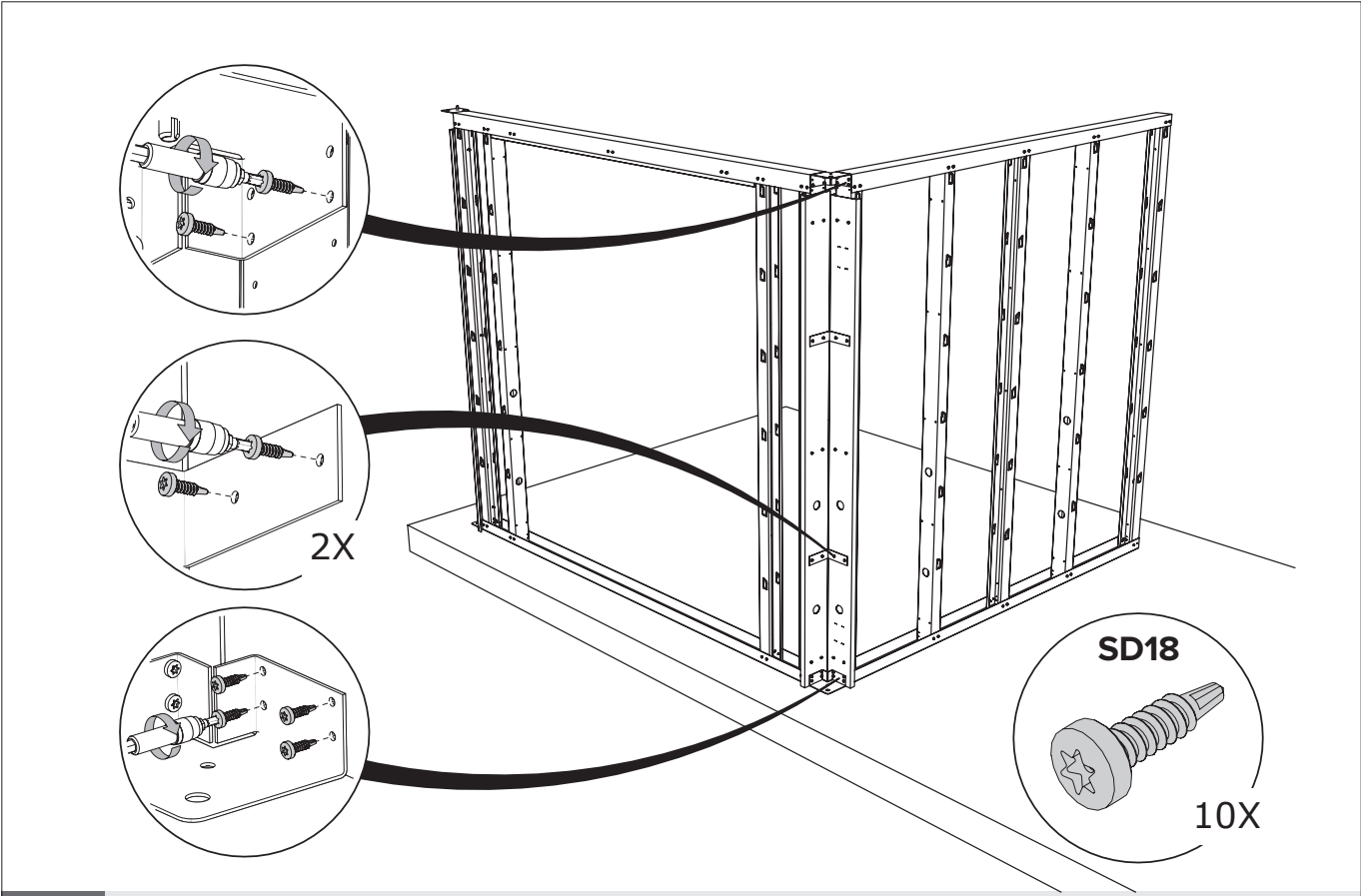

A + B Paroi / Wand / Wall / Wand

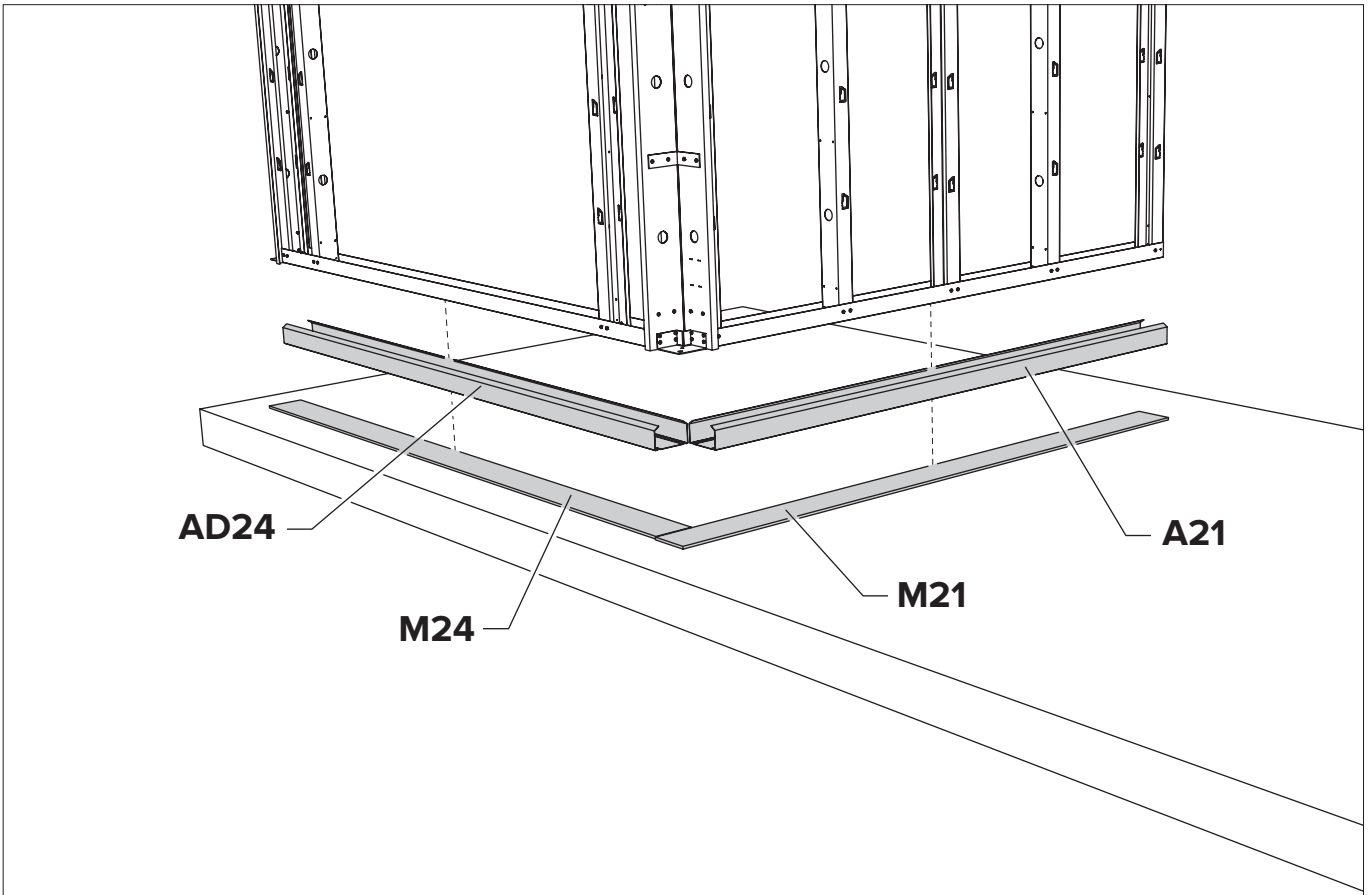

A + B Paroi / Wand / Wall / Wand

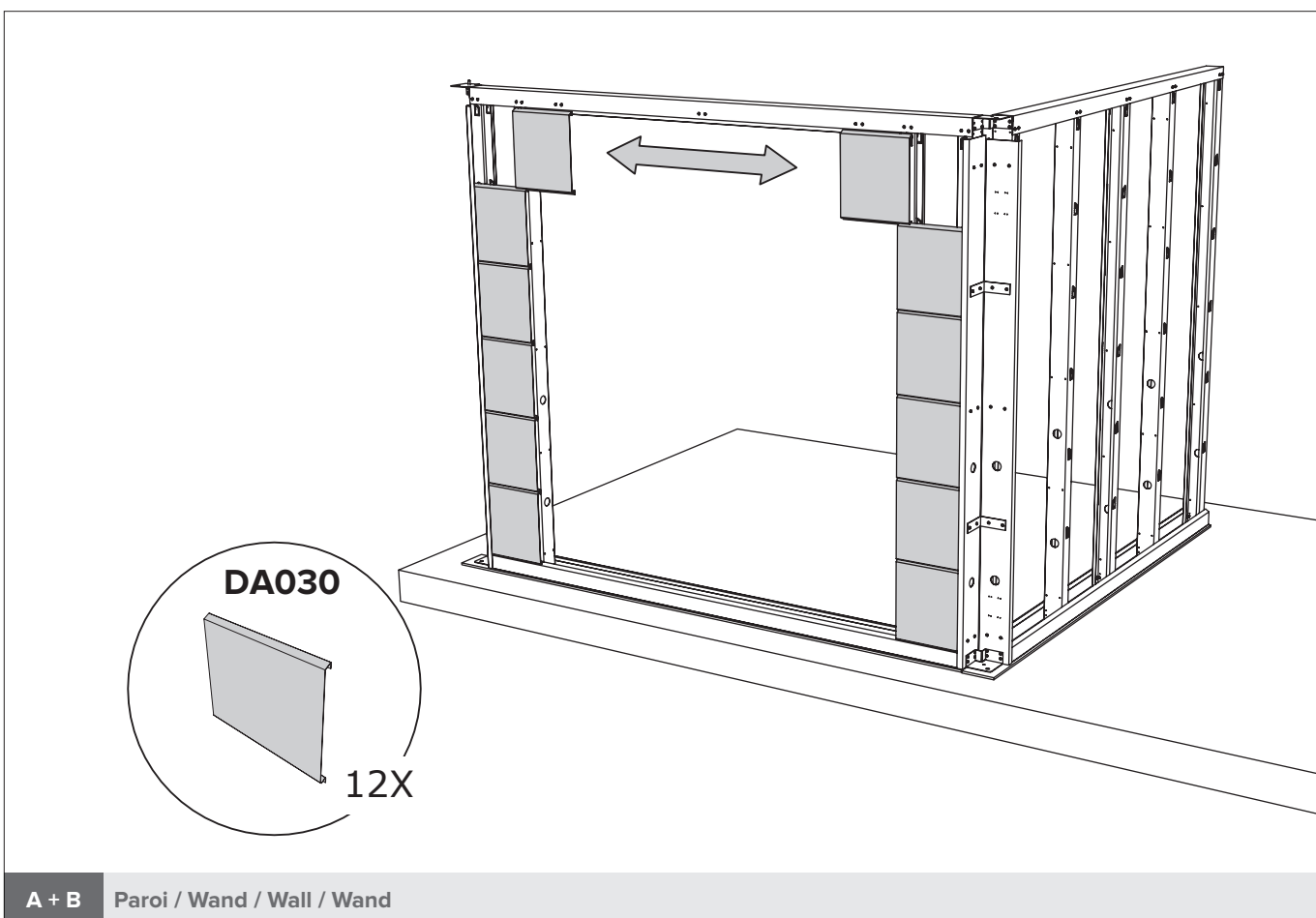
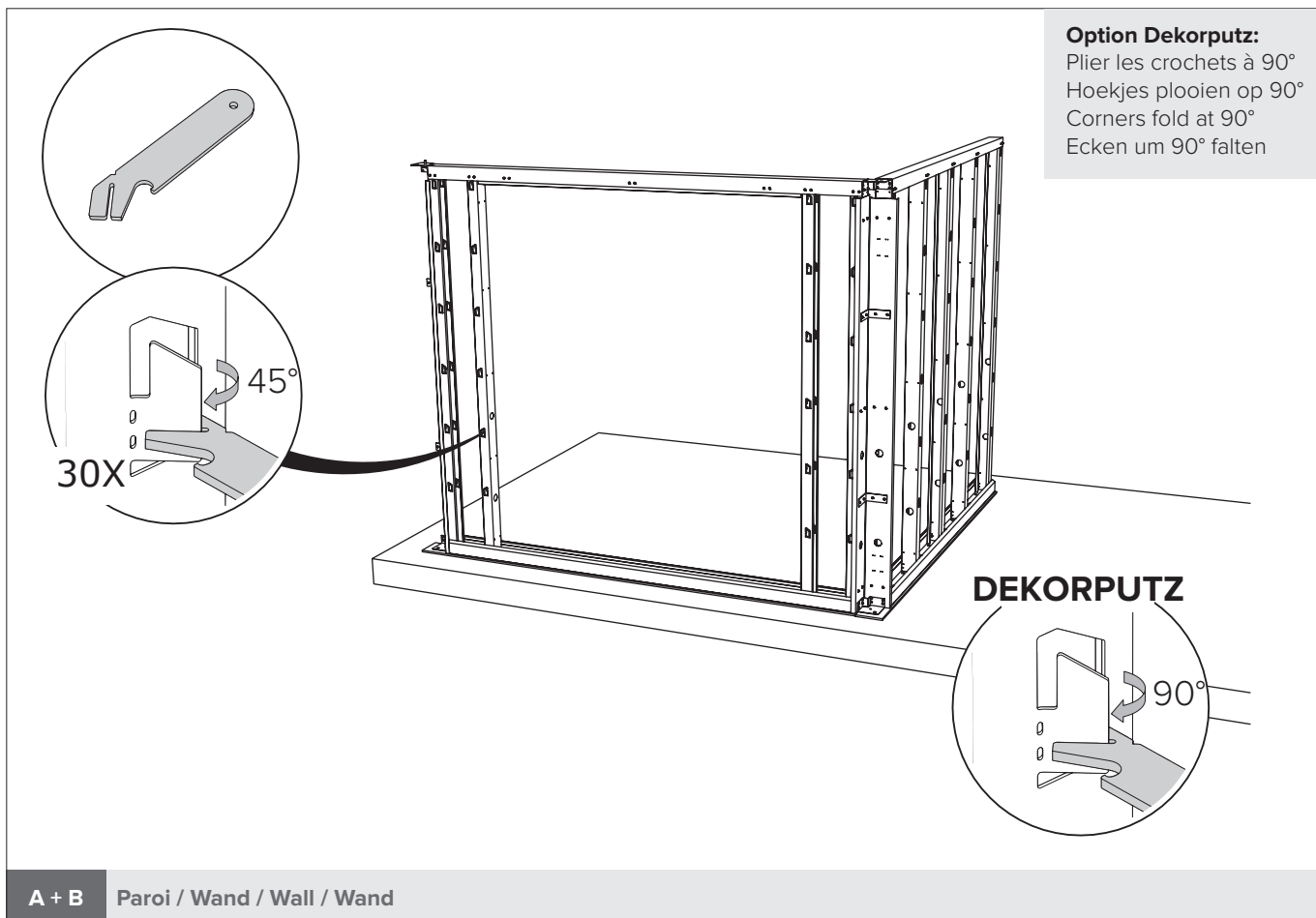

Option Dekorputz:

Plier les crochets à 90°
 Hoekjes plooiën op 90°
 Corners fold at 90°
 Ecken um 90° falten

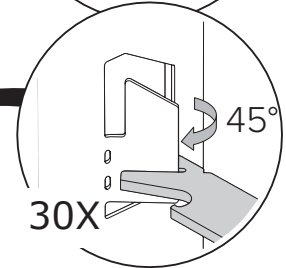
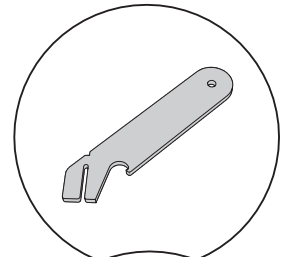
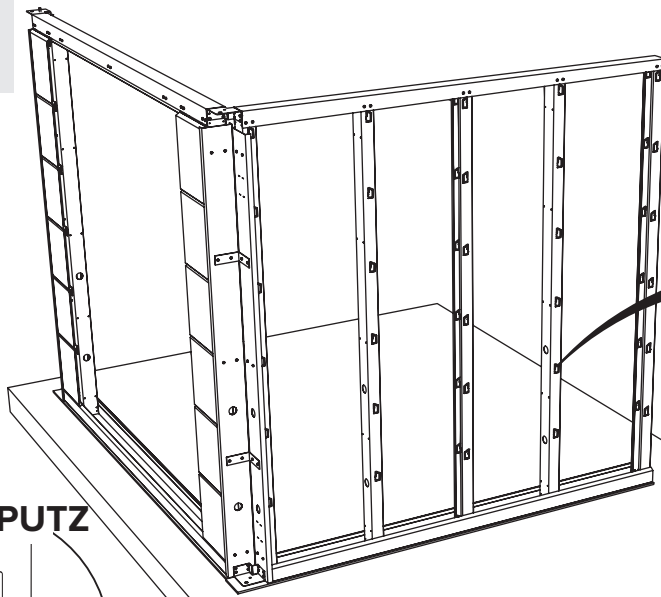

DEKORPUTZ

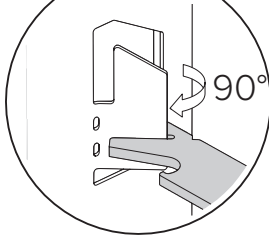

A + B Paroi / Wand / Wall / Wand

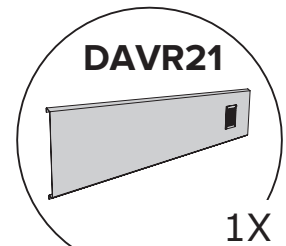
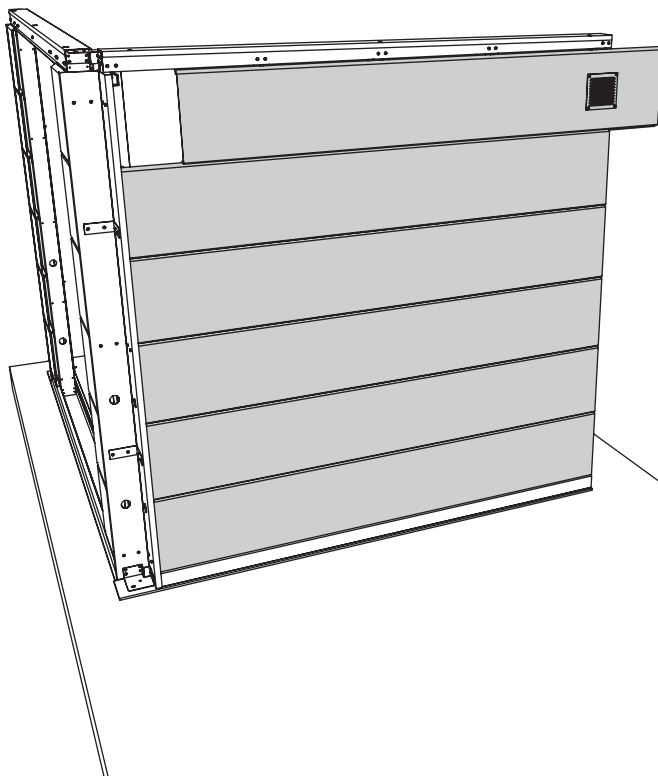

1X

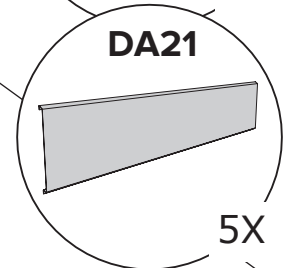

5X

A + B Paroi / Wand / Wall / Wand

revêtement intérieur
 binnenbekleding
 interior lining
 Innenverkleidung

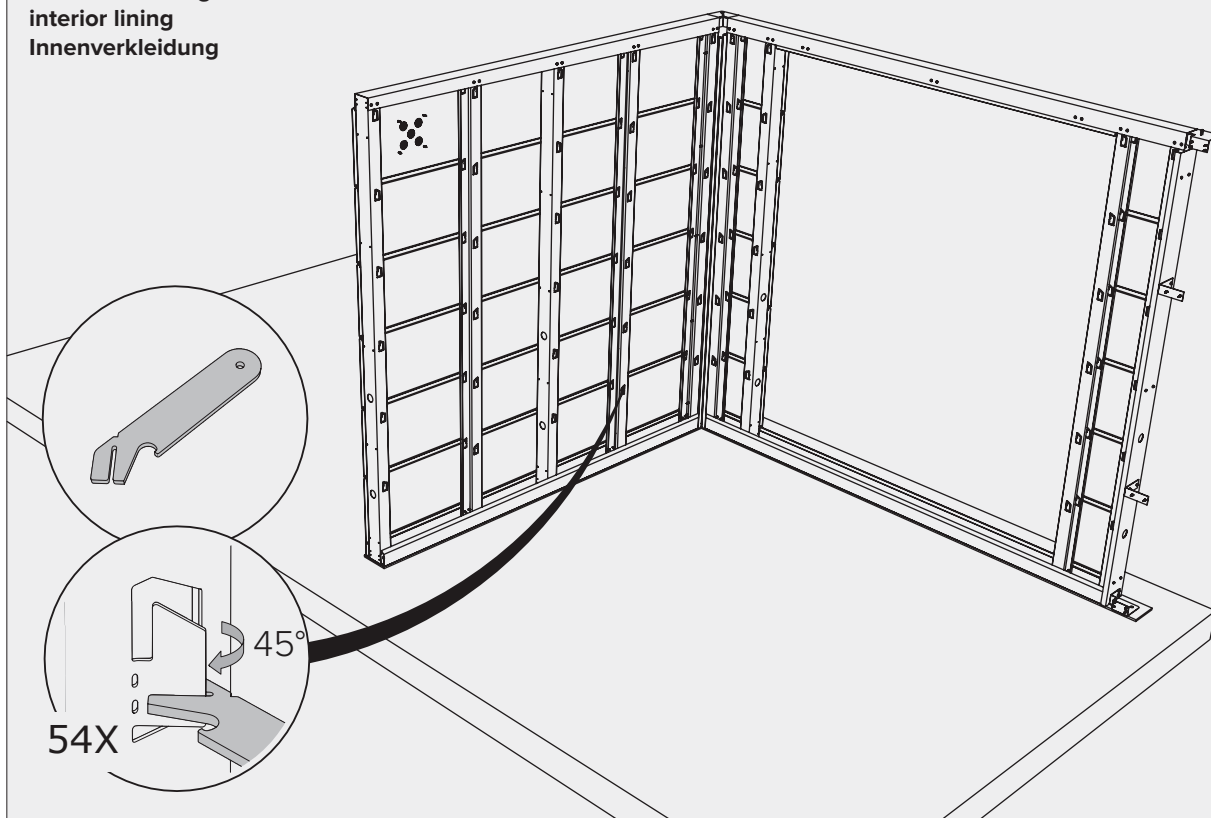

A + B Paroi / Wand / Wall / Wand

Option / Optie / Option / Option

revêtement intérieur
 binnenbekleding
 interior lining
 Innenverkleidung

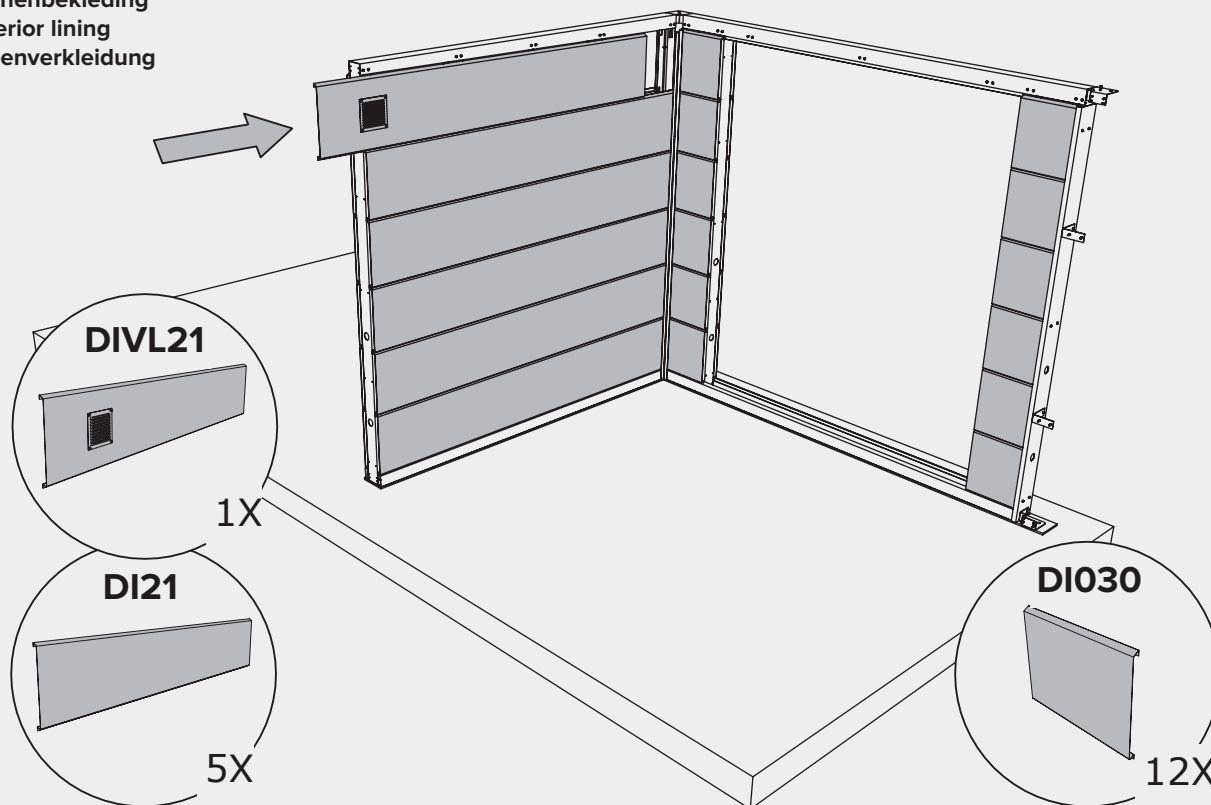

A + B Paroi / Wand / Wall / Wand

Option / Optie / Option / Option

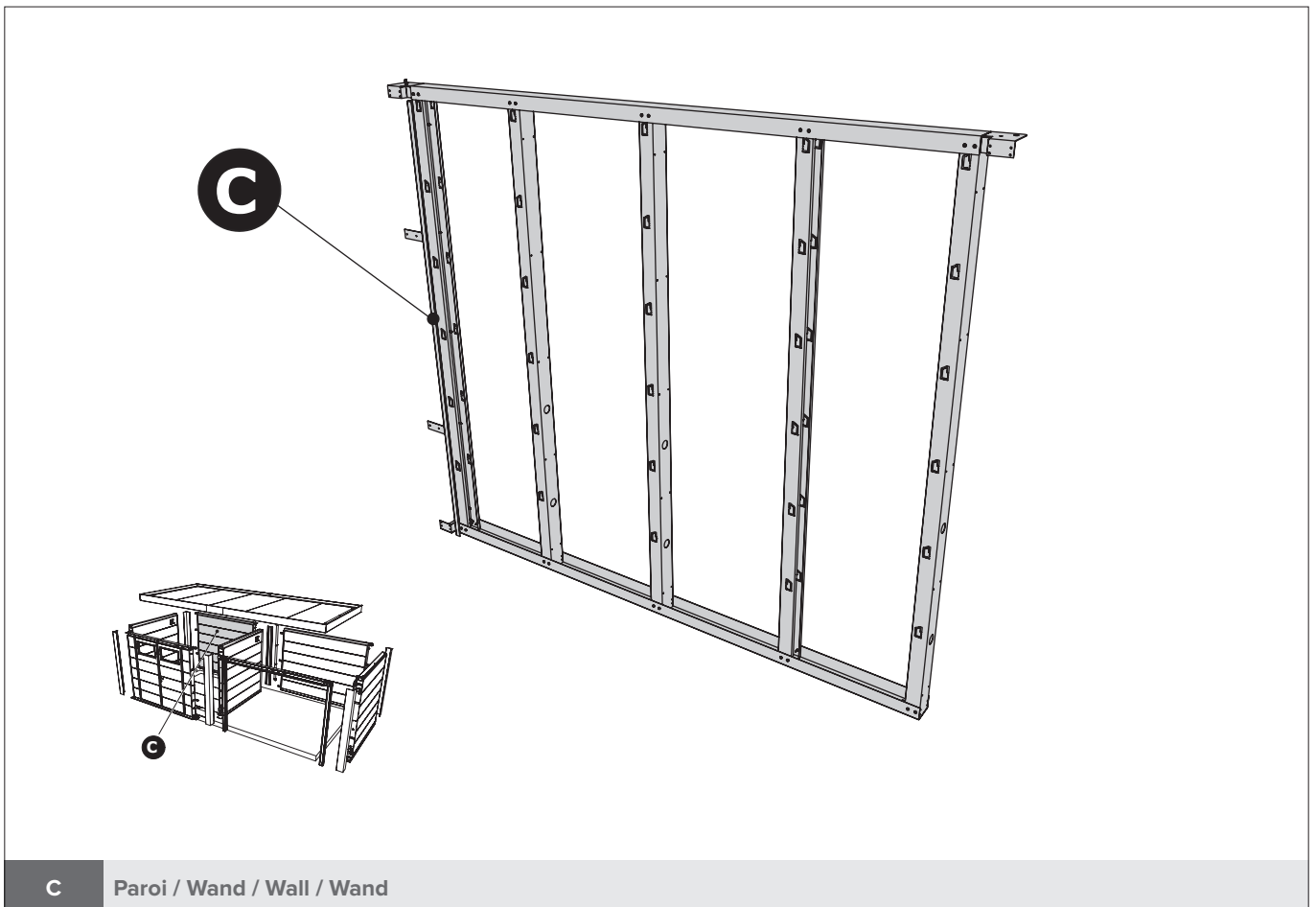
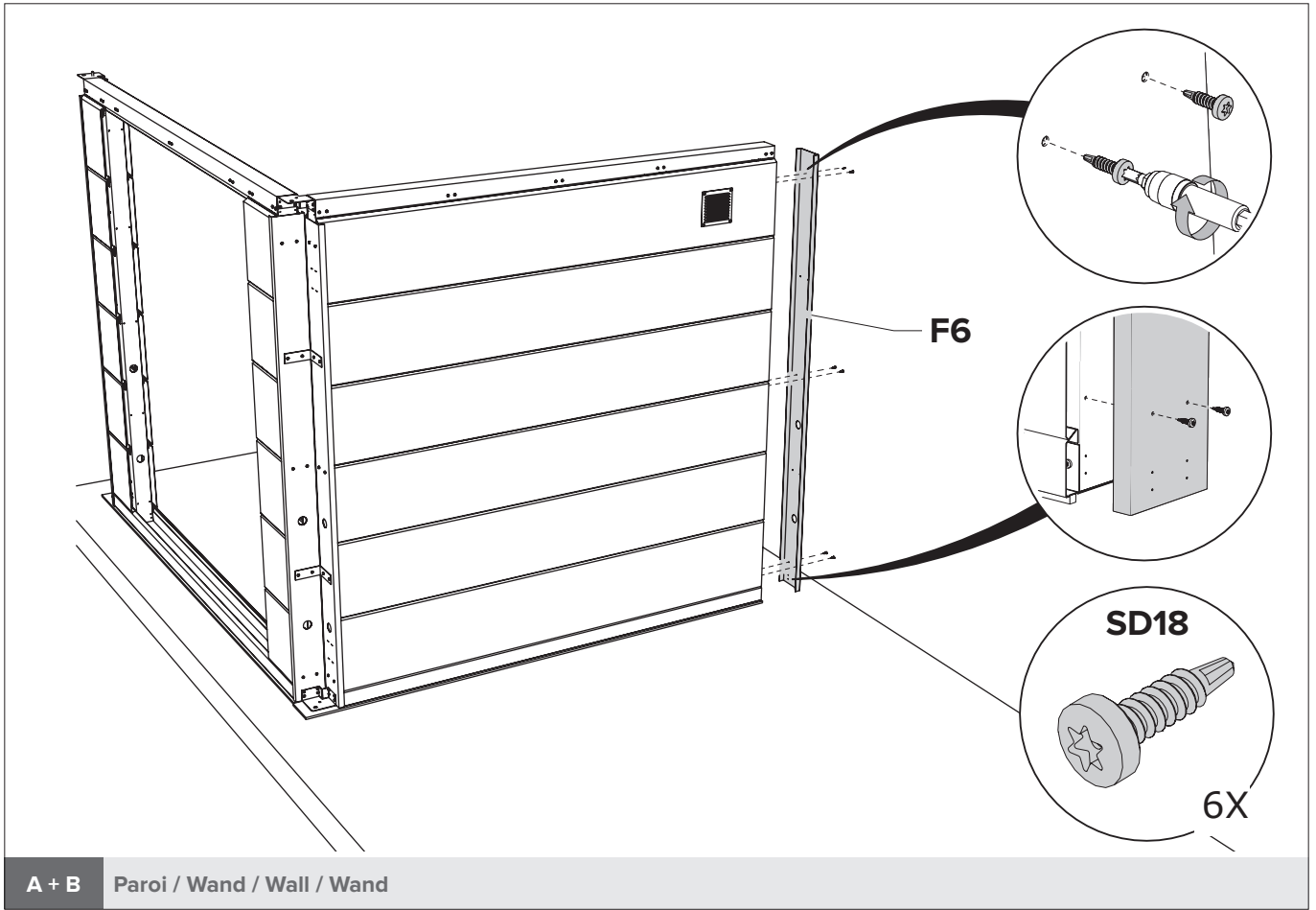

Le principe de la construction du mur, voir pages 8 à 11 (POW).
 Het principe van de opbouw van de wand, zie pagina 8 tot en met 11 (POW).
 The principle of building the wall, see pages 8 through 11 (POW).
 Das Prinzip des Baus der Mauer finden Sie auf den Seiten 8 bis 11 (POW).

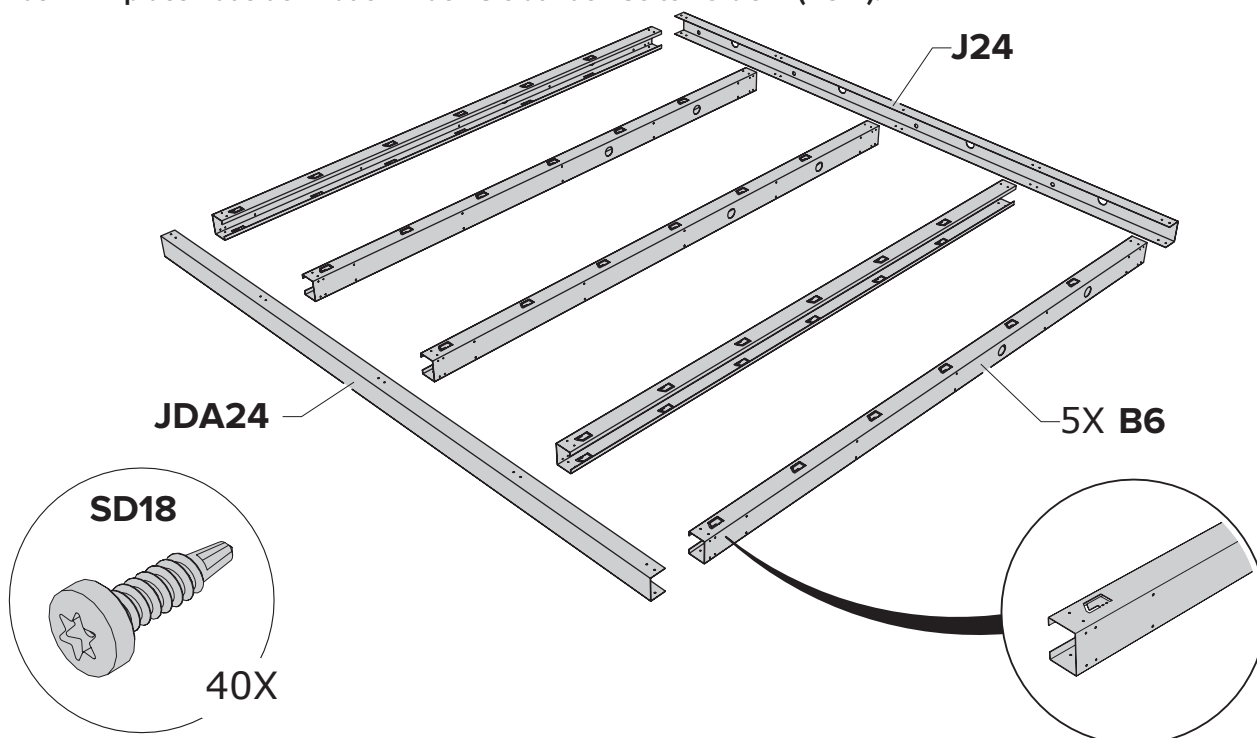

C Paroi / Wand / Wall / Wand

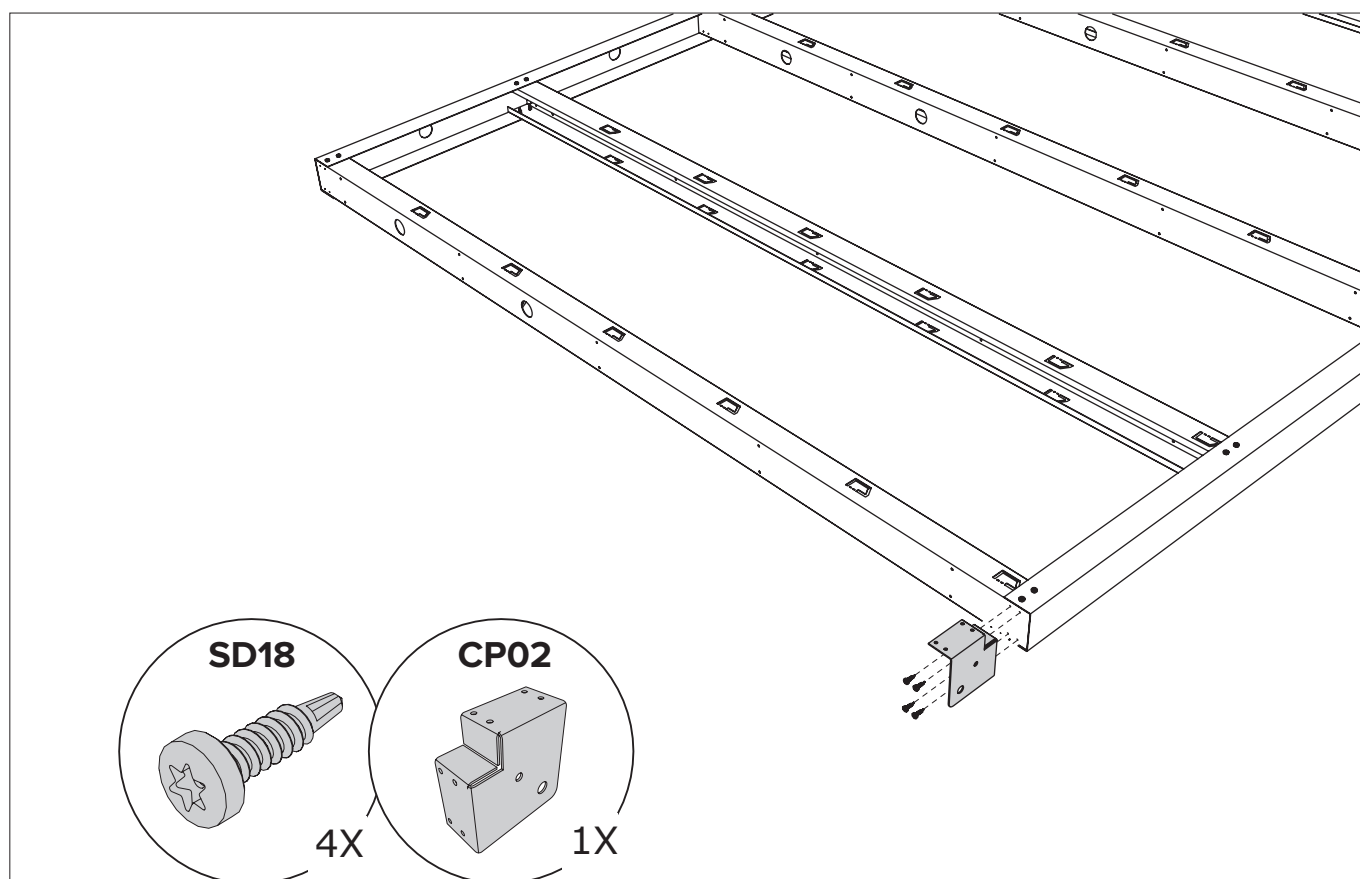

C Paroi / Wand / Wall / Wand

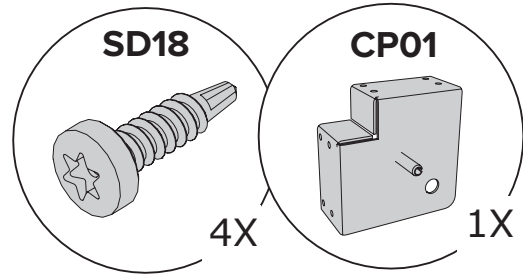
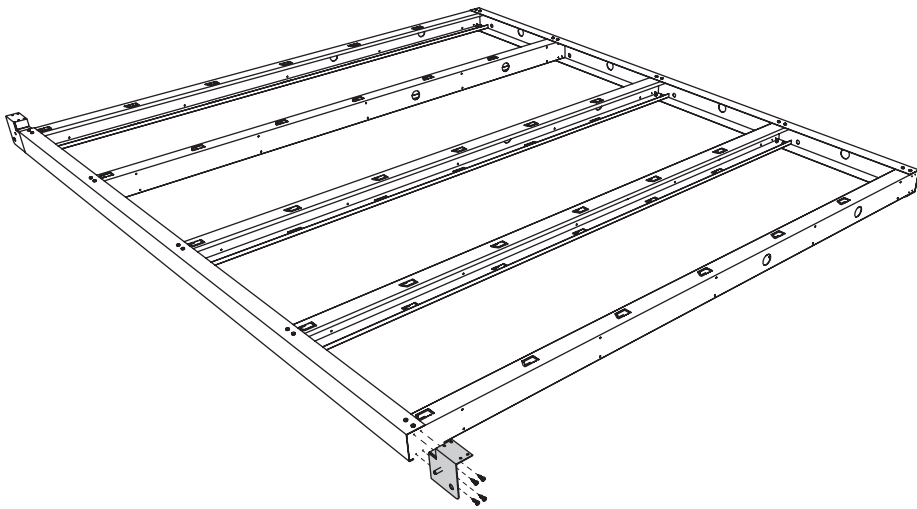

C Paroi / Wand / Wall / Wand

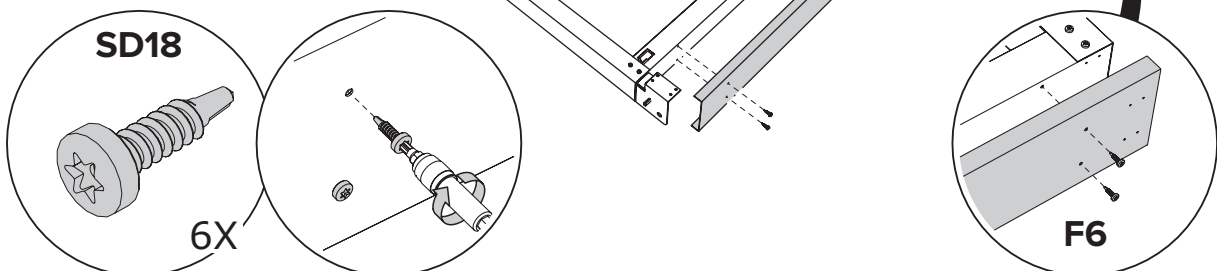
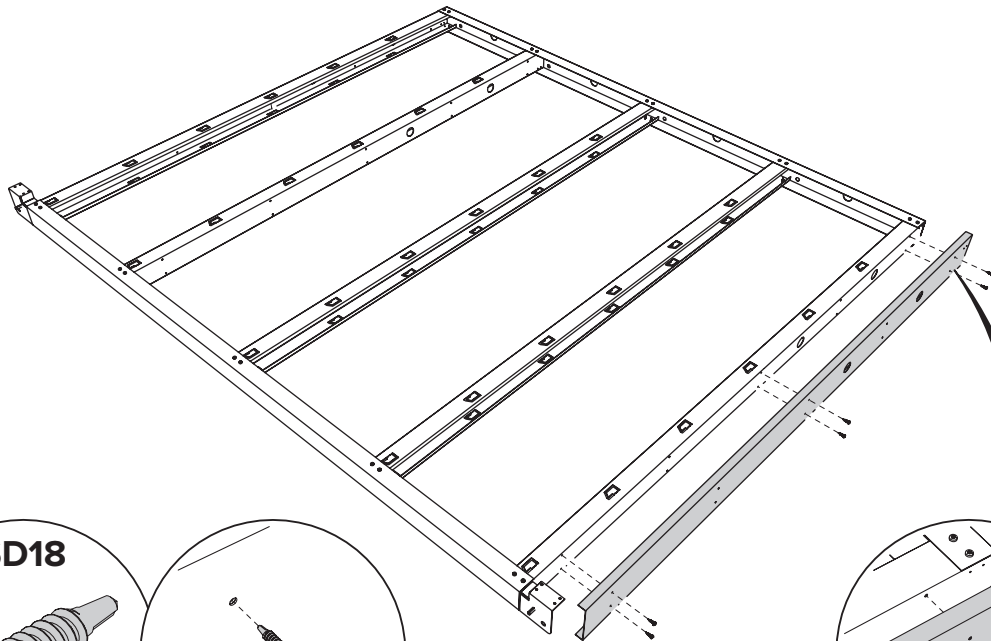

C Paroi / Wand / Wall / Wand

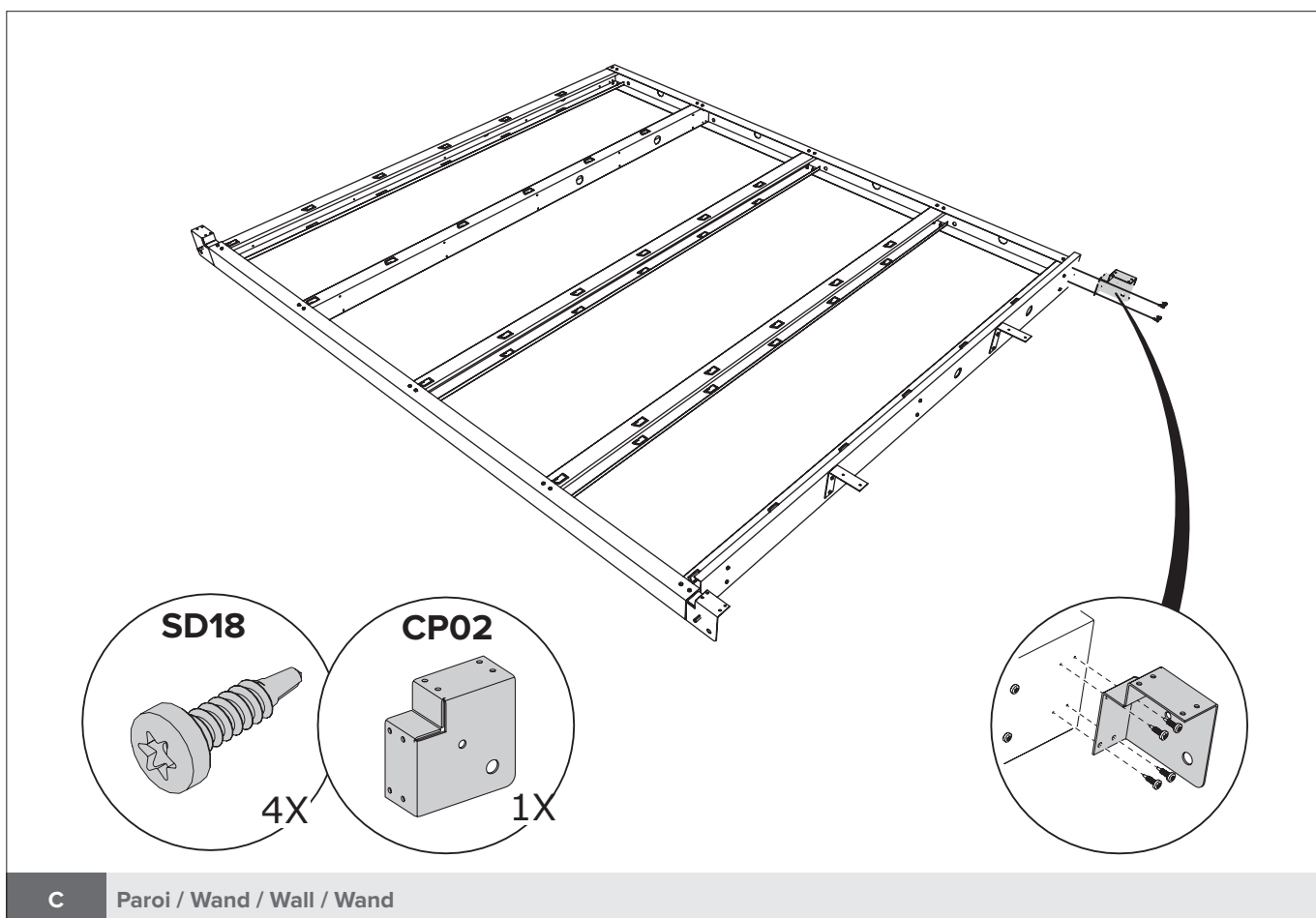
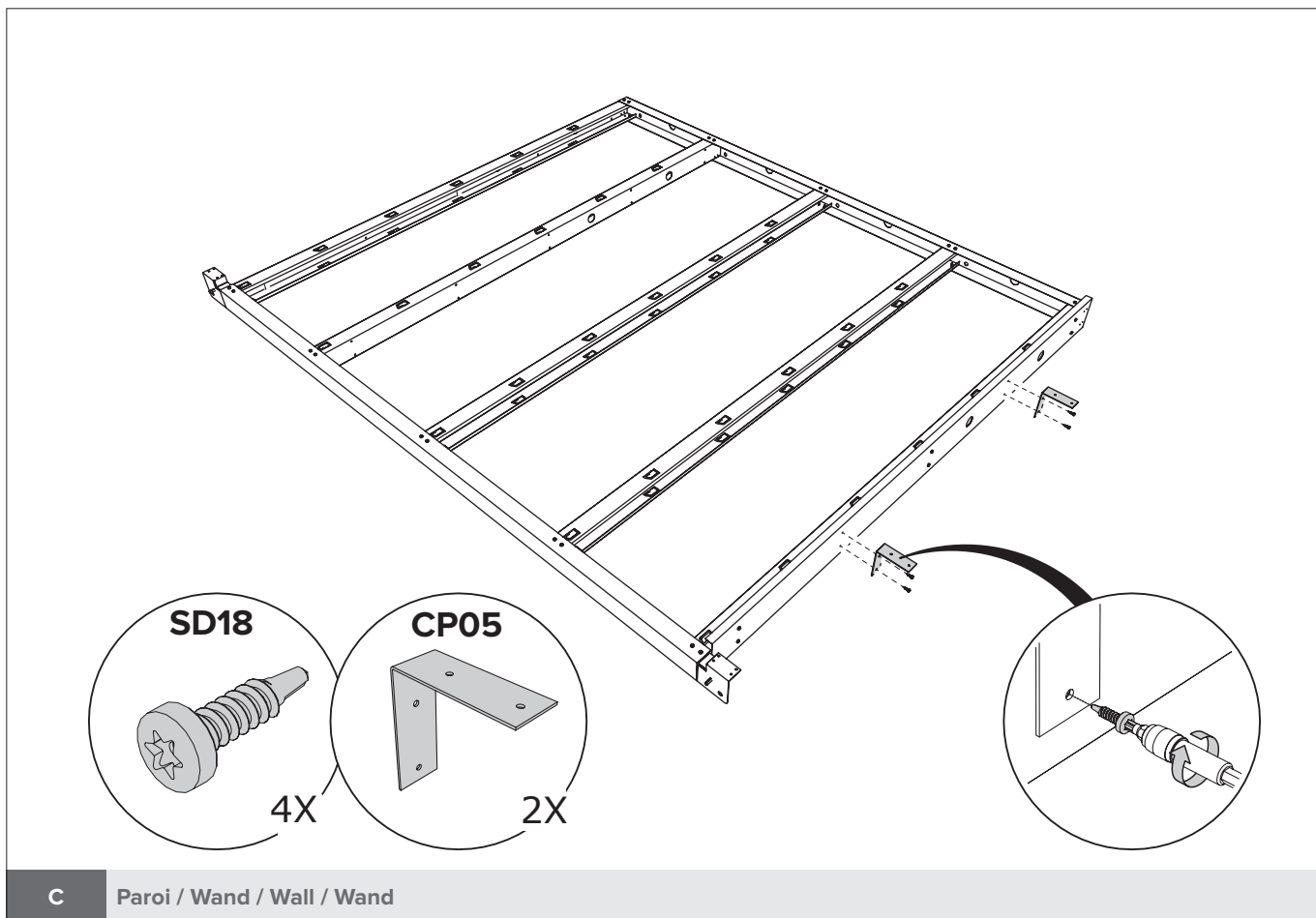

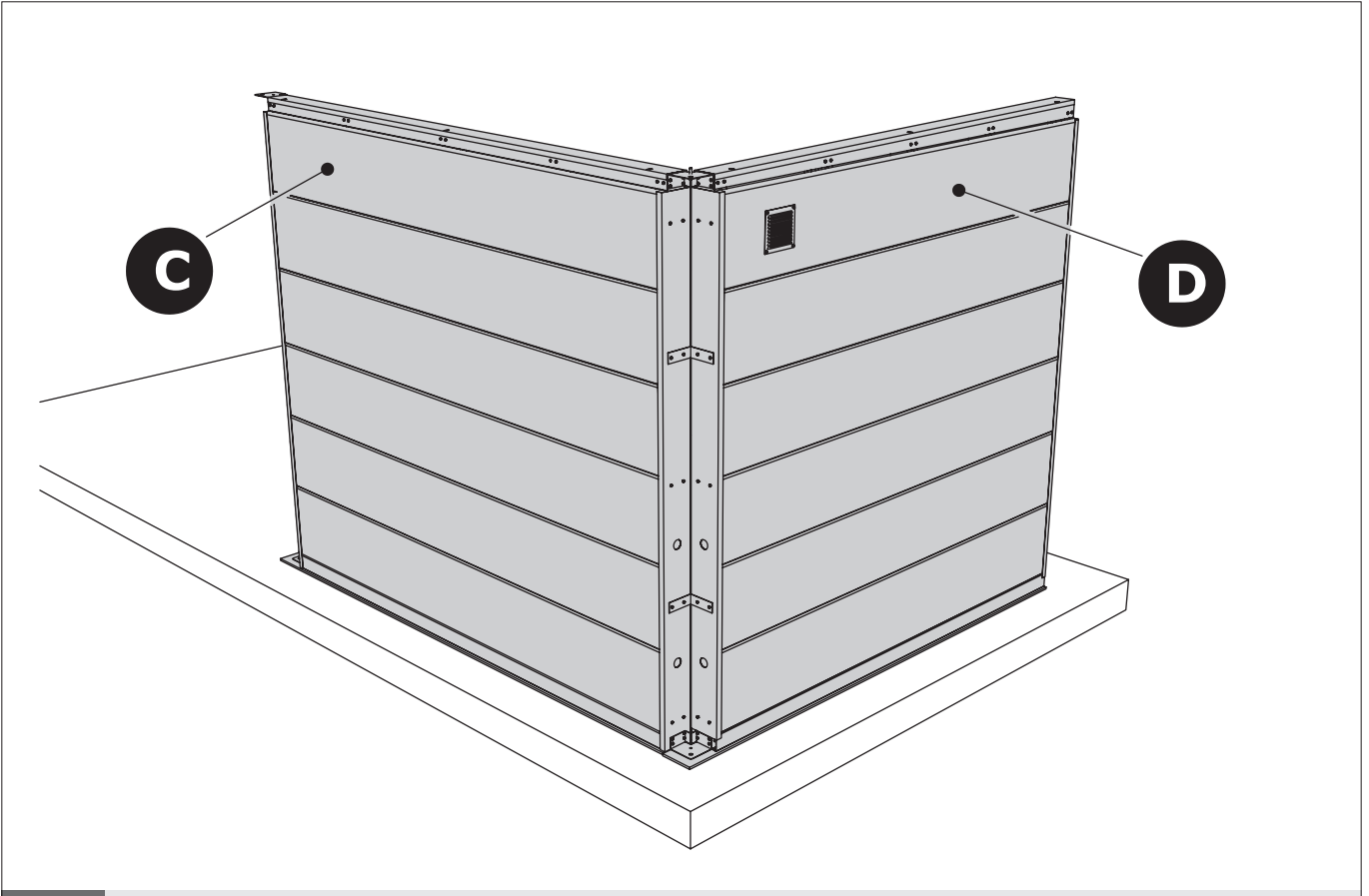

C + D Paroi / Wand / Wall / Wand

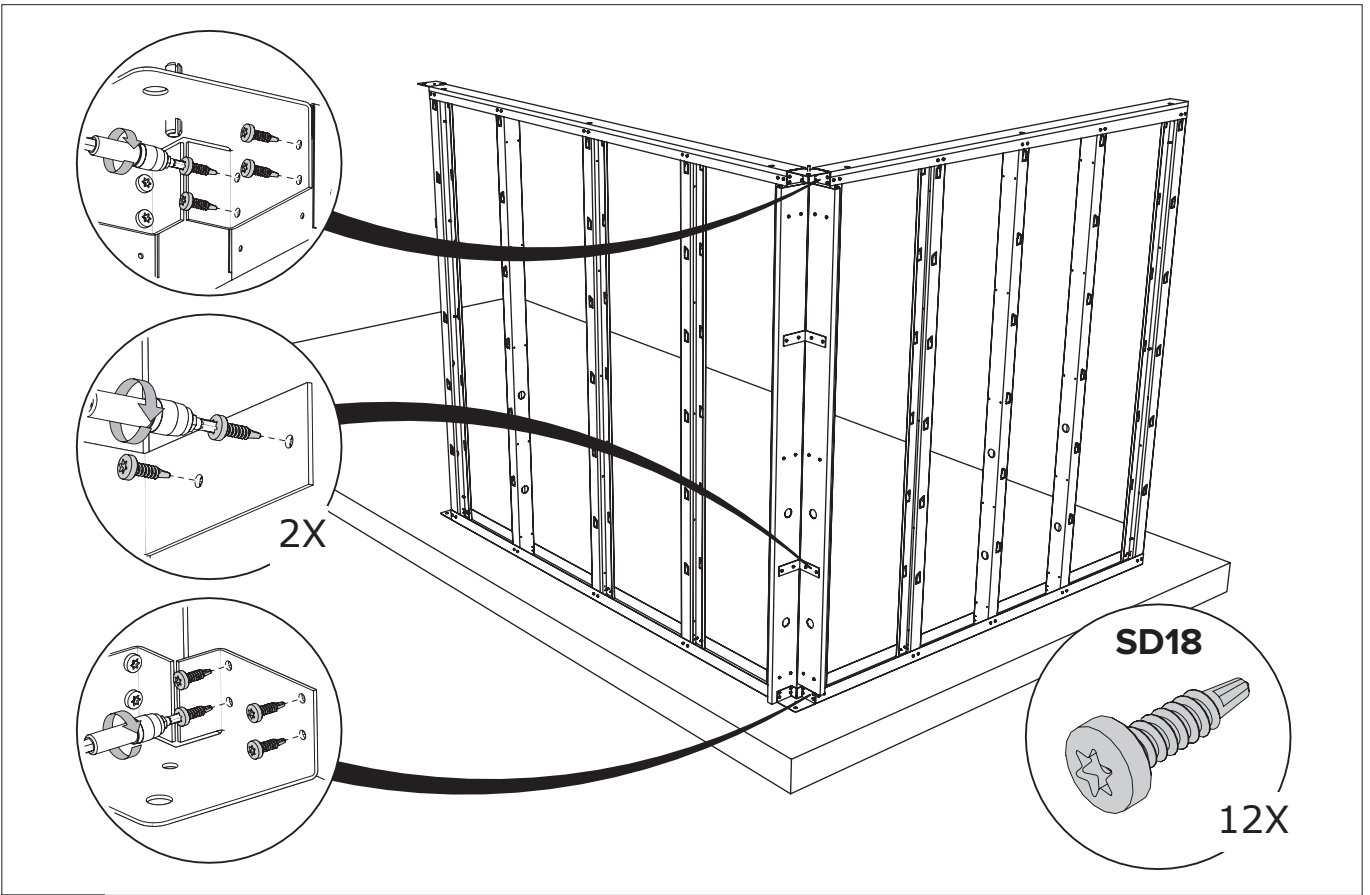

C + D Paroi / Wand / Wall / Wand

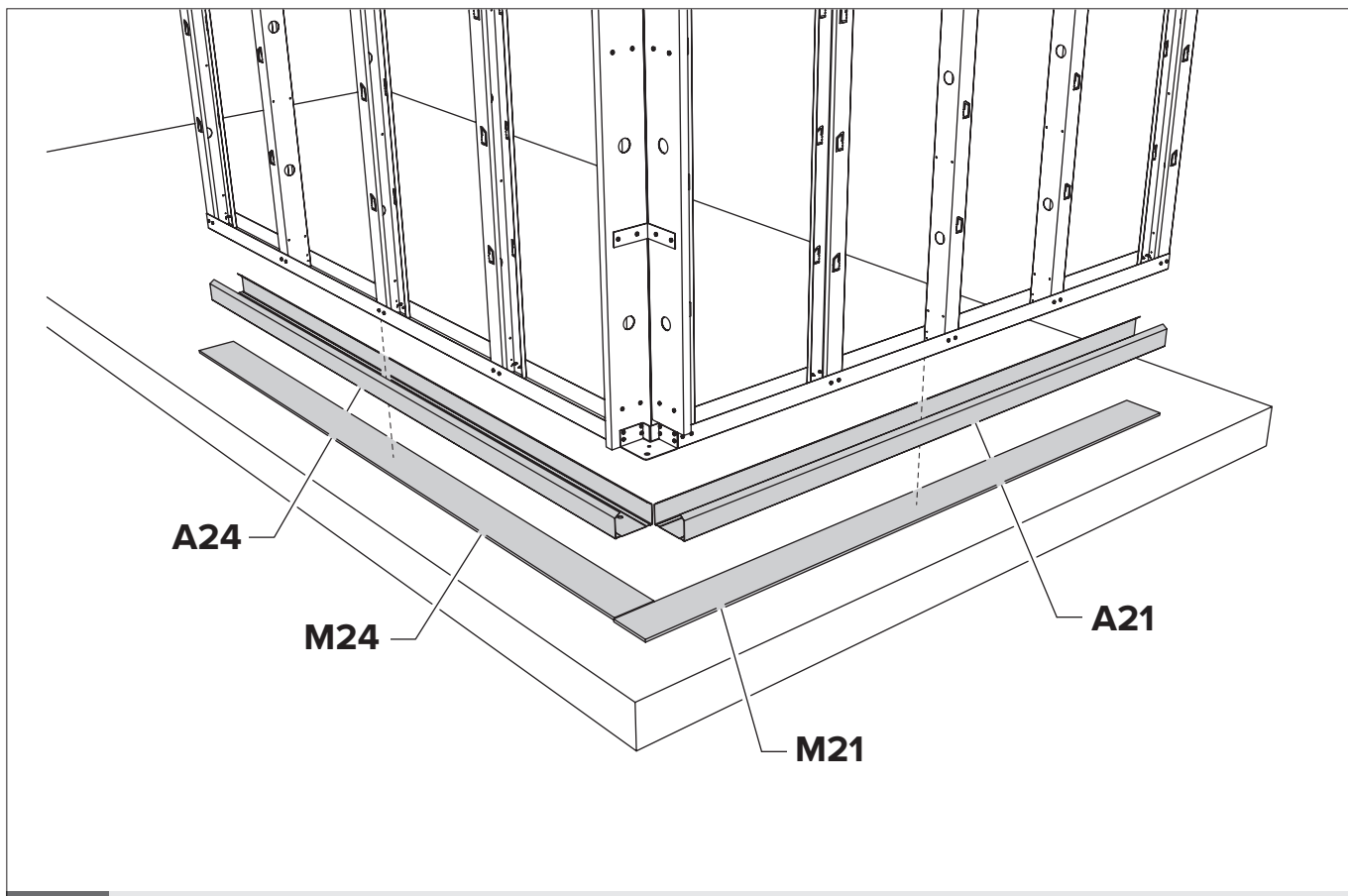

C + D Paroi / Wand / Wall / Wand

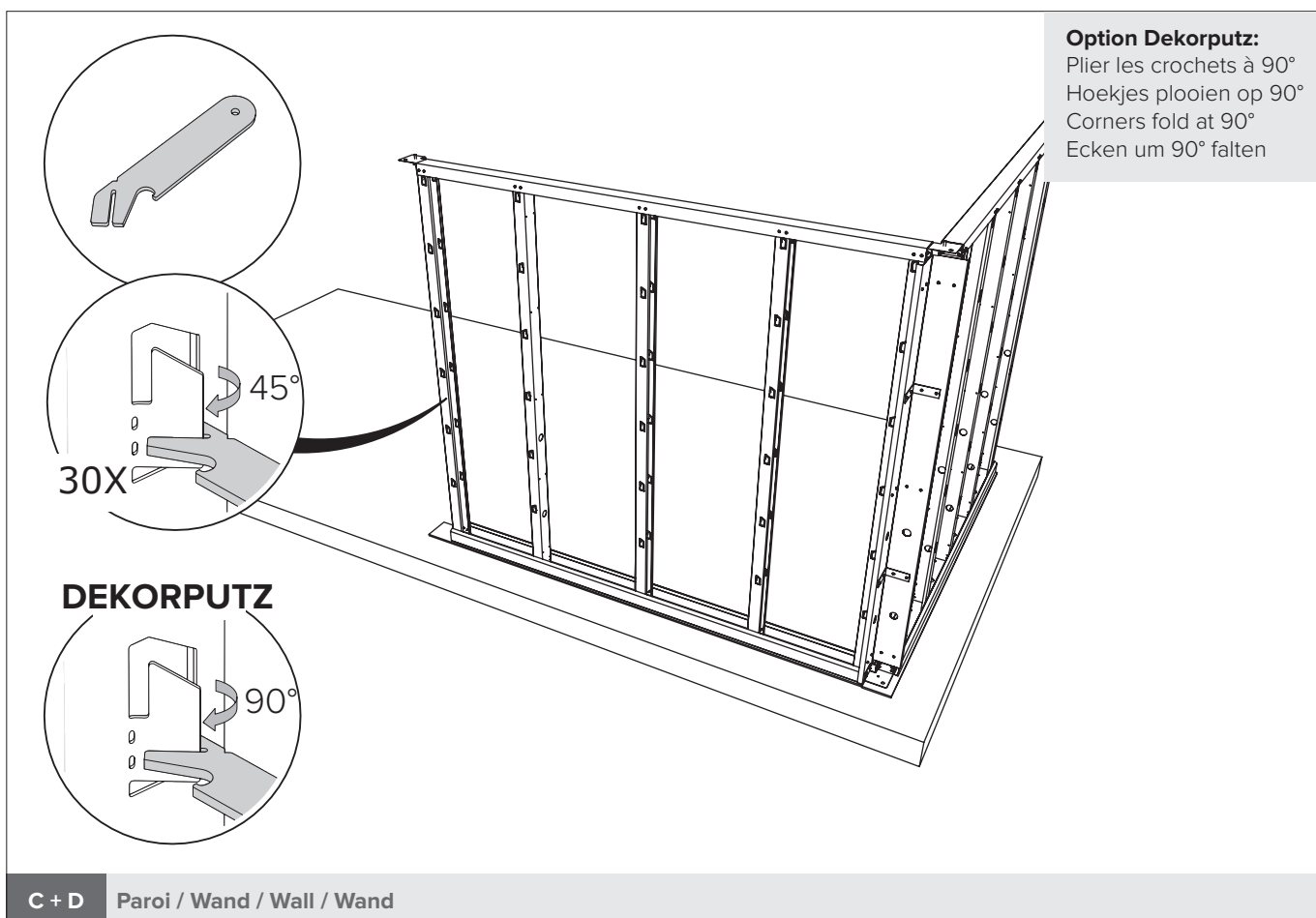

C + D Paroi / Wand / Wall / Wand

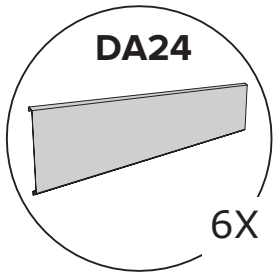
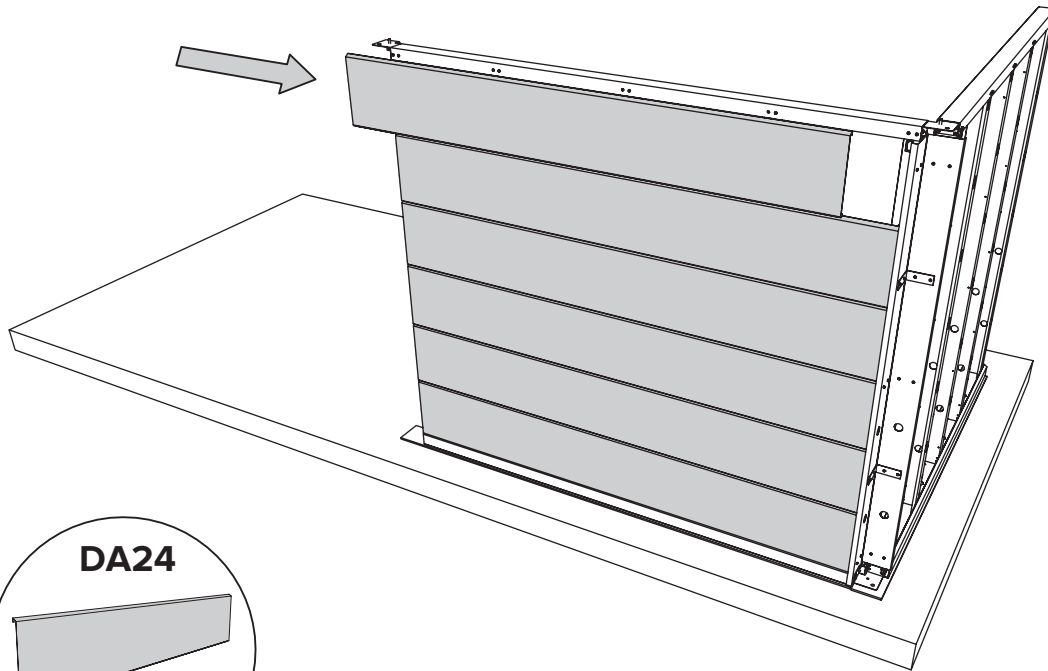

C + D Paroi / Wand / Wall / Wand

Option Dekorputz:

Plier les crochets à 90°
 Hoekjes plooiën op 90°
 Corners fold at 90°
 Ecken um 90° falten

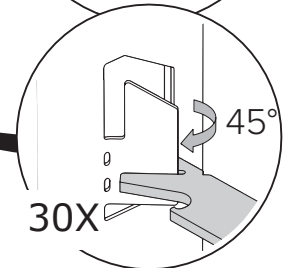
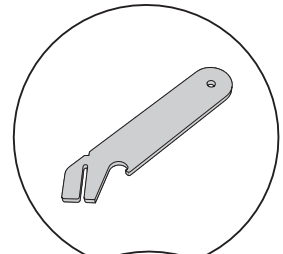
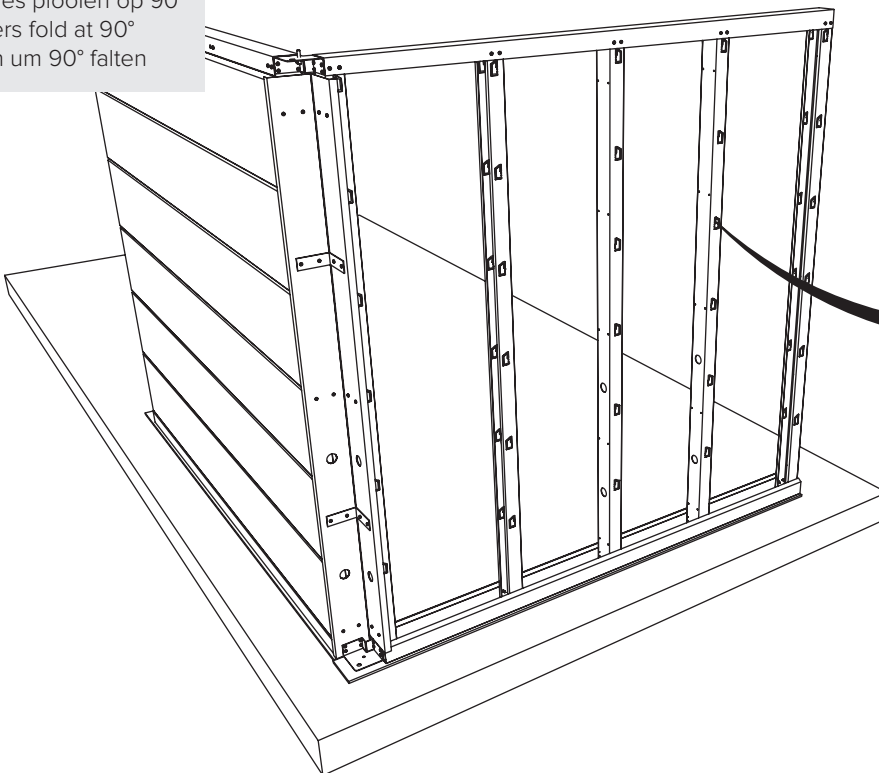

DEKORPUTZ

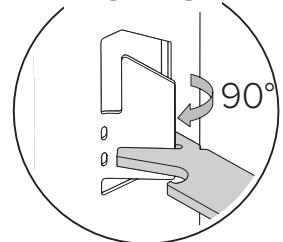

C + D Paroi / Wand / Wall / Wand

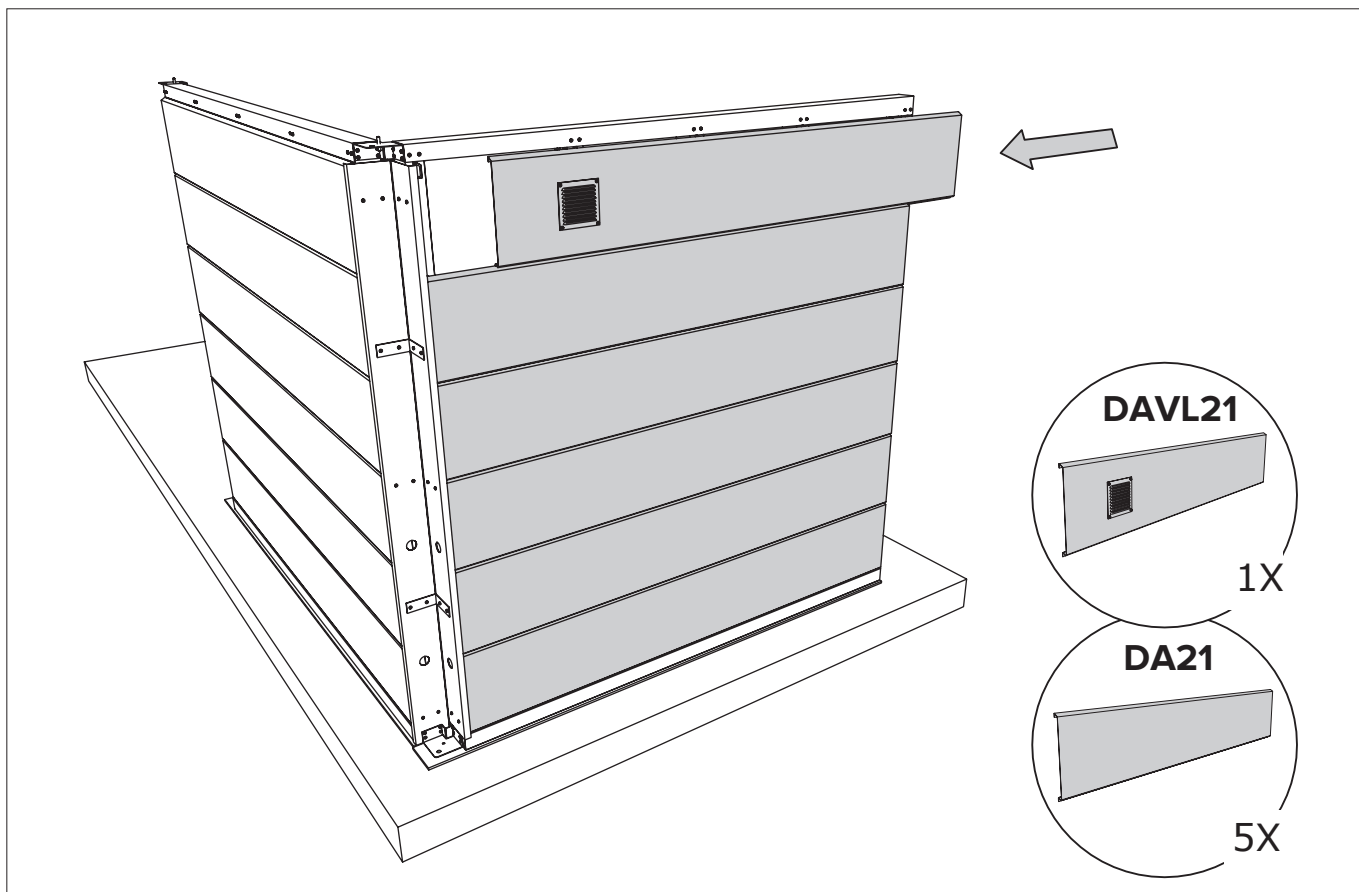

C + D Paroi / Wand / Wall / Wand

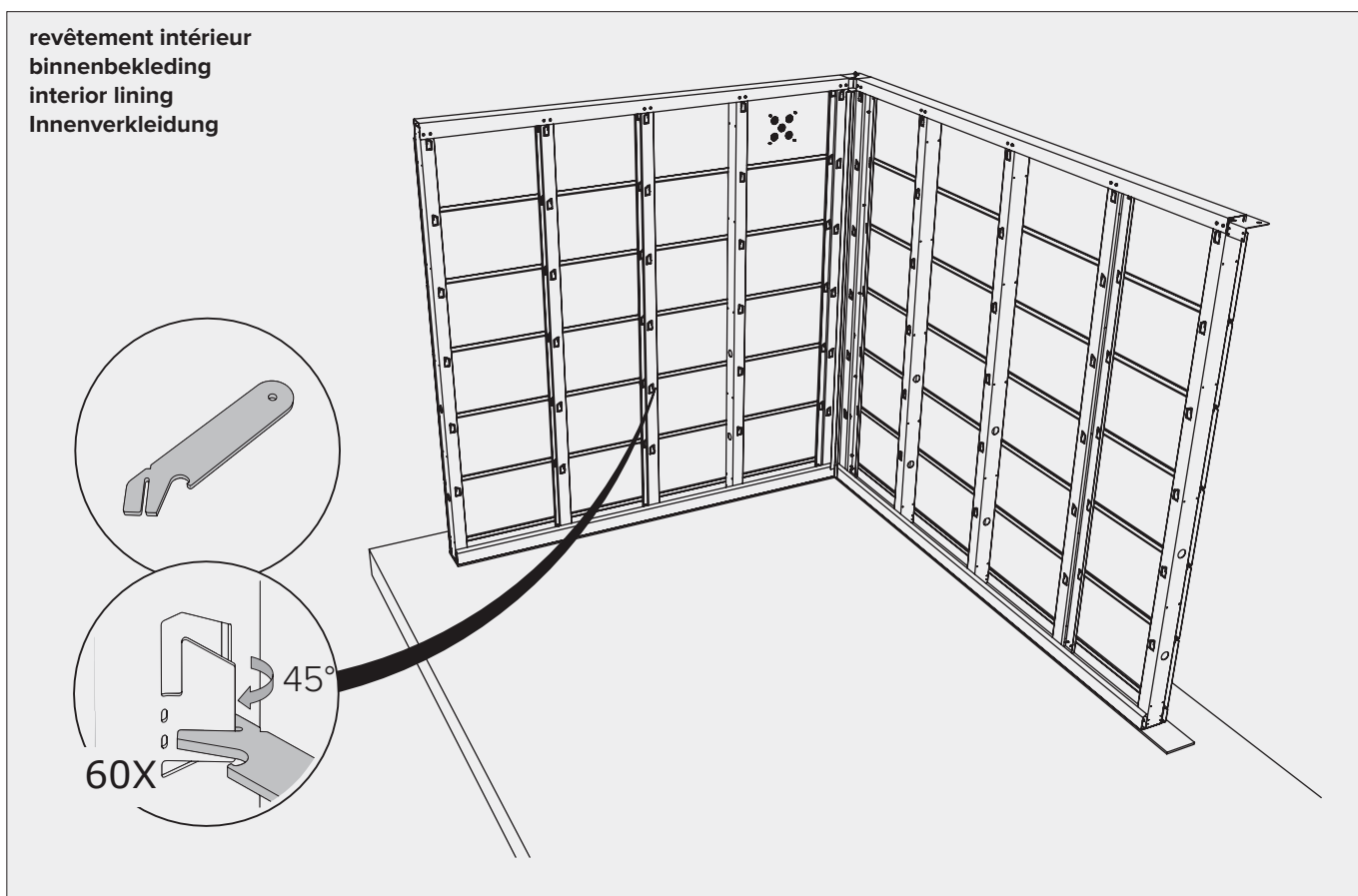

C + D Paroi / Wand / Wall / Wand Option / Optie / Option / Option

revêtement intérieur et plaque perforée
 binnenbekleding en geperforeerde plaat
 interior lining and perforated plate
 Innenverkleidung und perforierte Platte

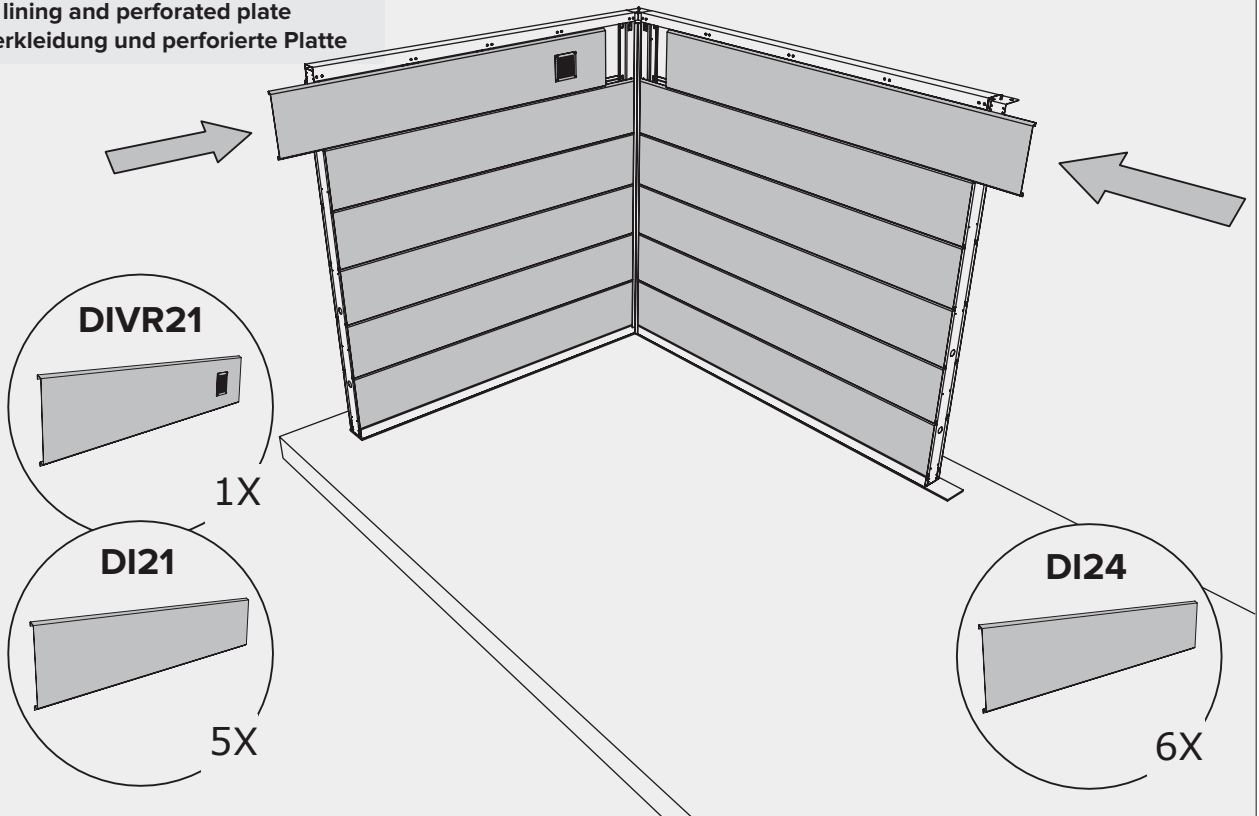

C + D Paroi / Wand / Wall / Wand

Option / Optie / Option / Option

revêtement intérieur et plaque perforée
 binnenbekleding en geperforeerde plaat
 interior lining and perforated plate
 Innenverkleidung und perforierte Platte

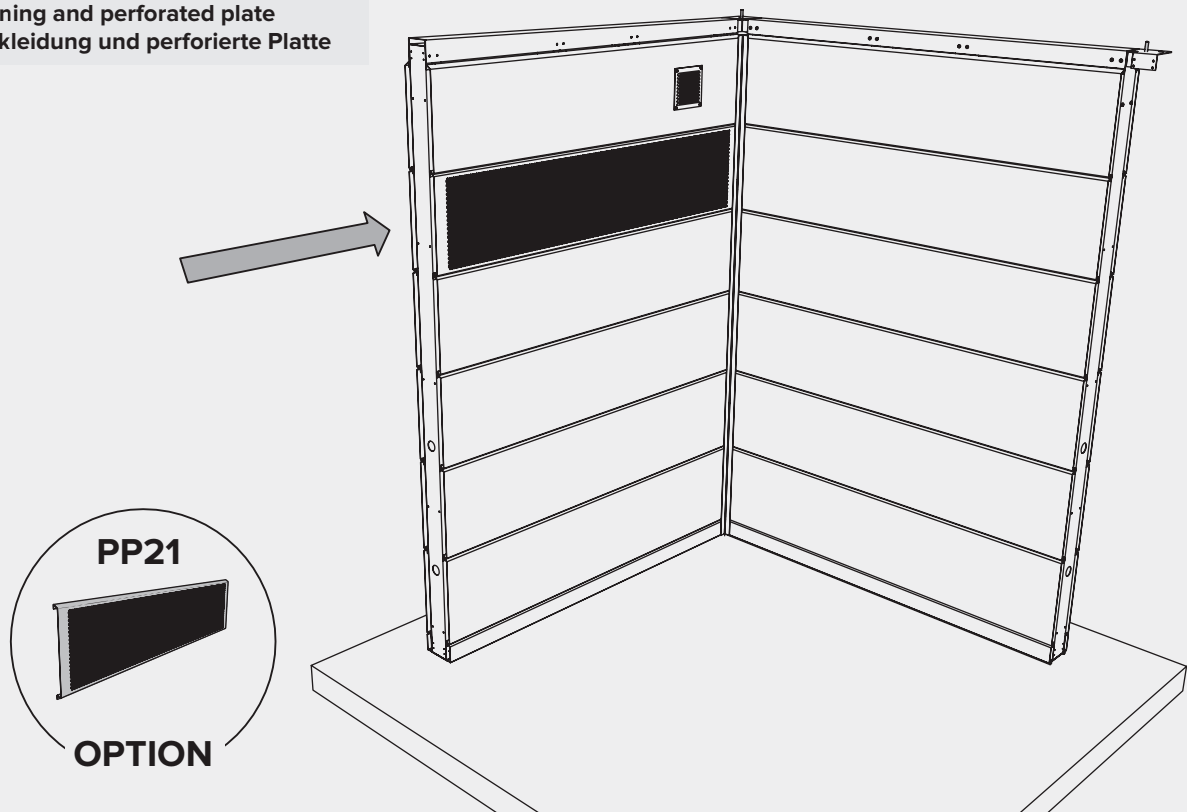

C + D Paroi / Wand / Wall / Wand

Option / Optie / Option / Option

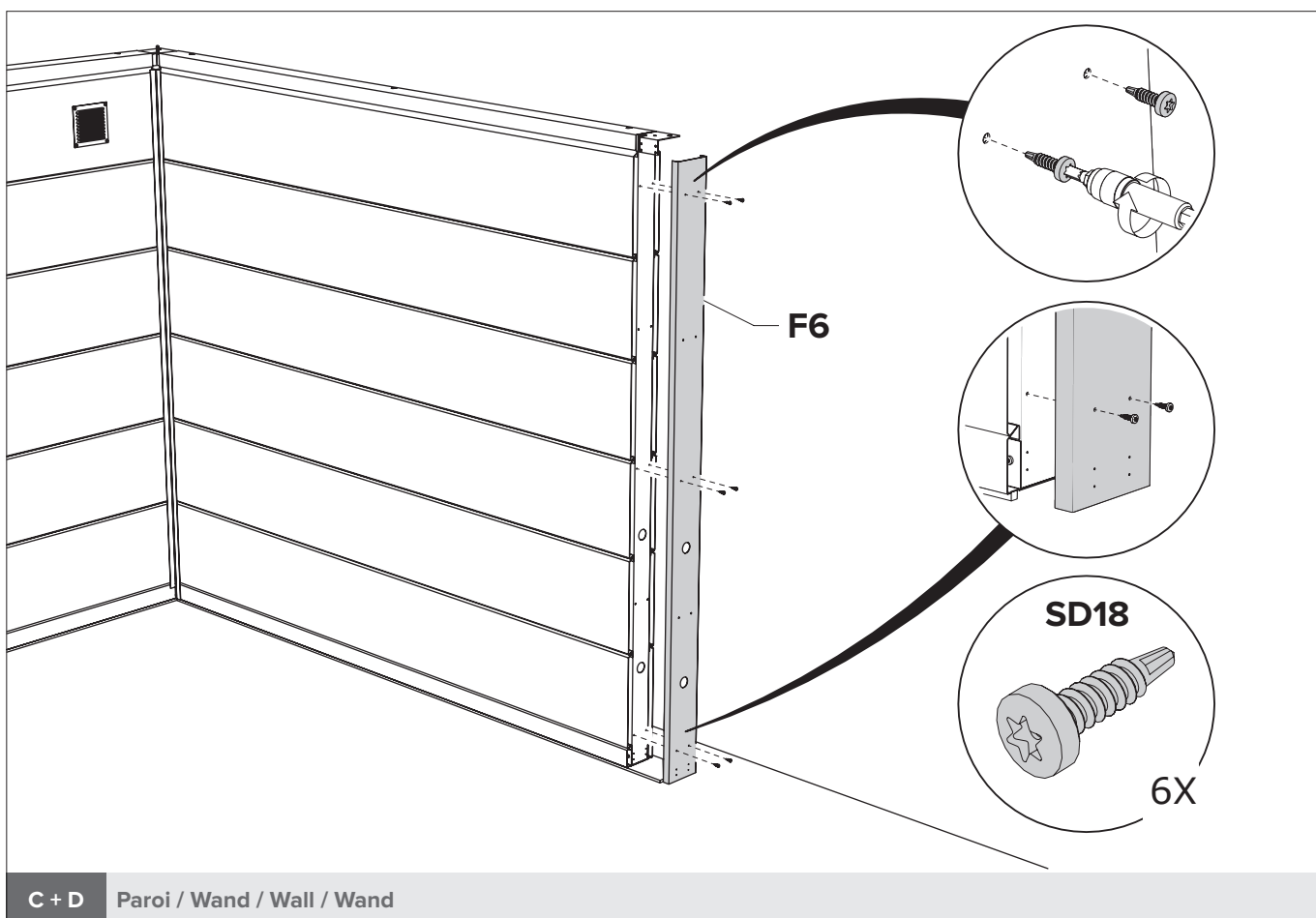
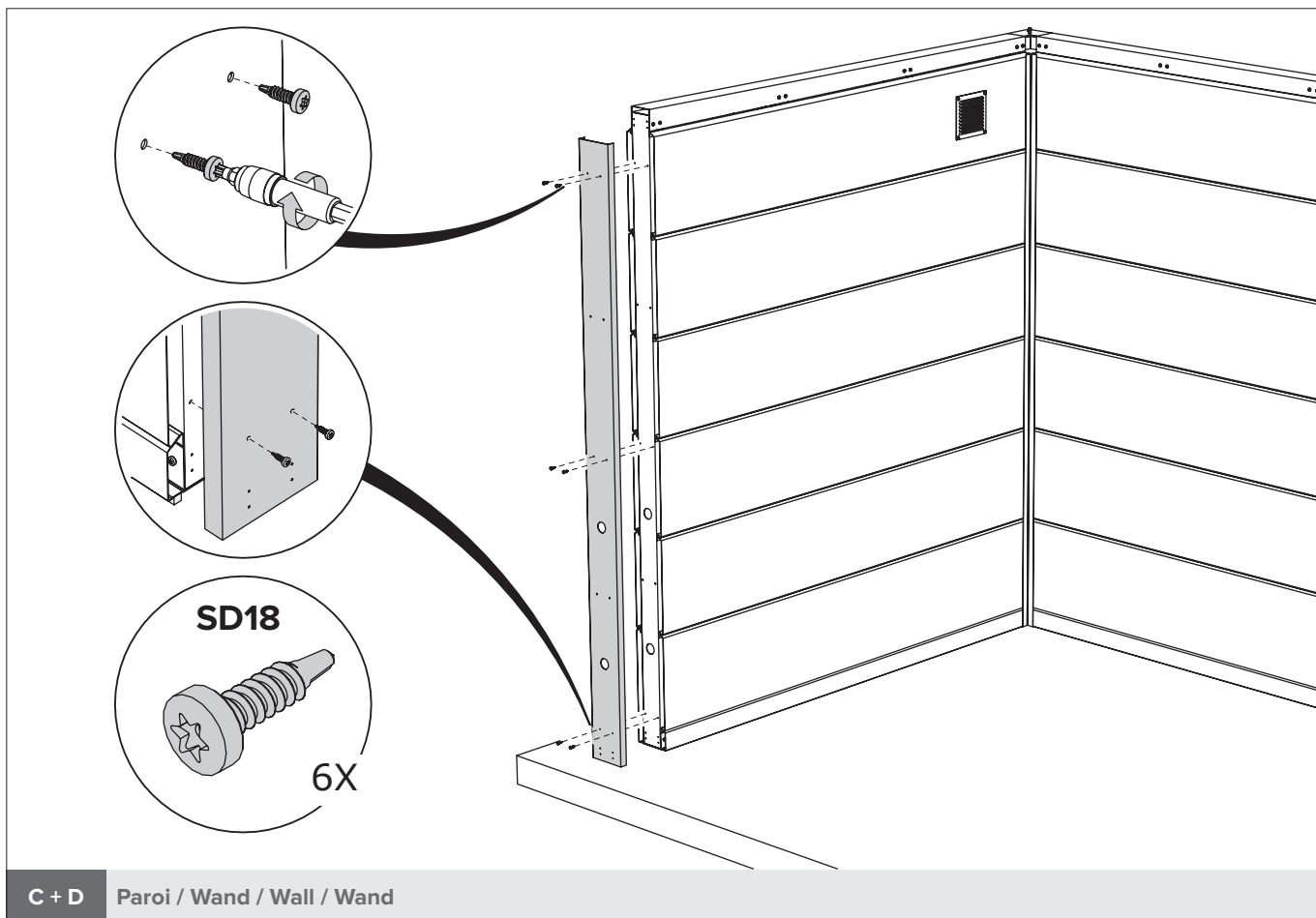

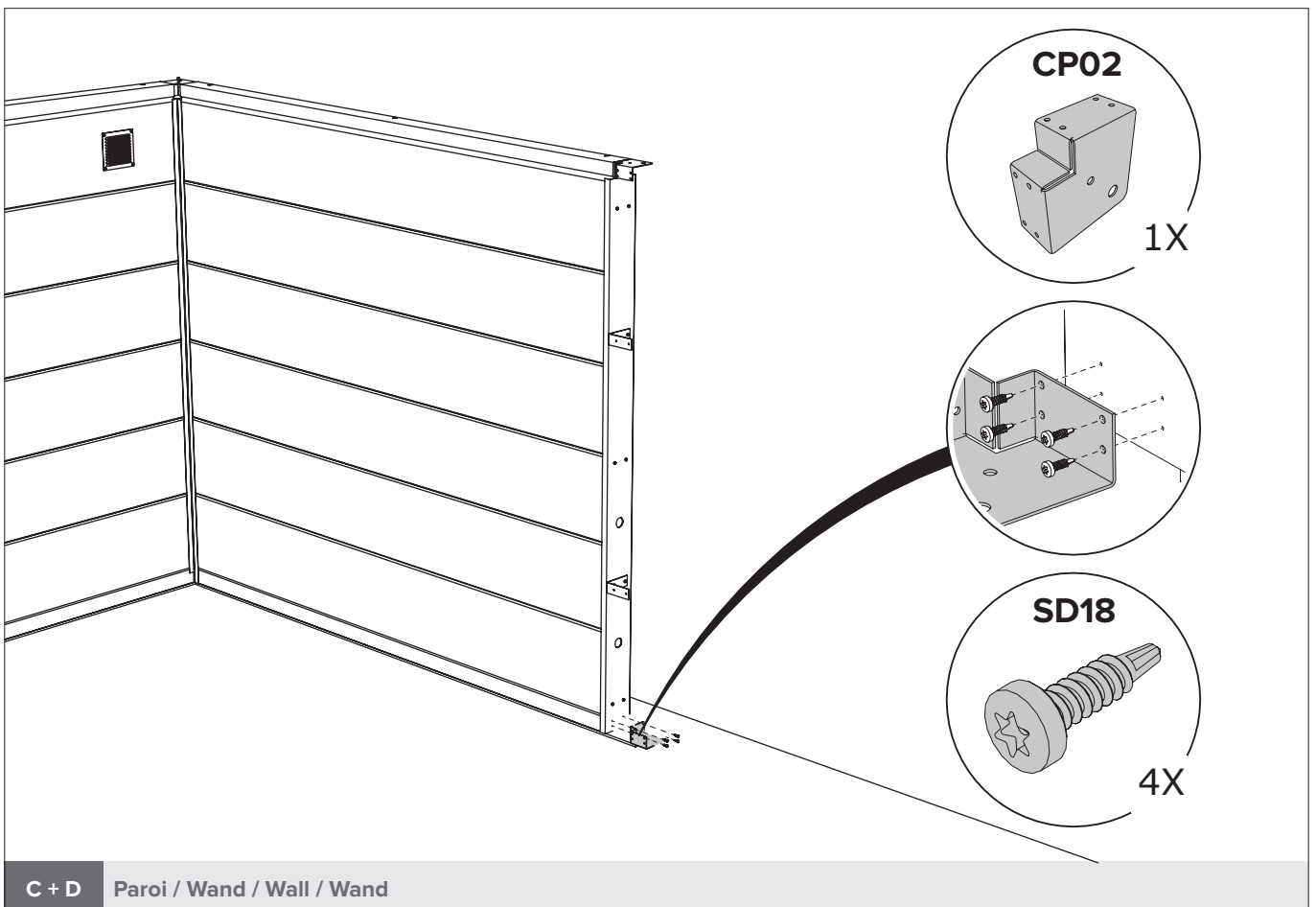
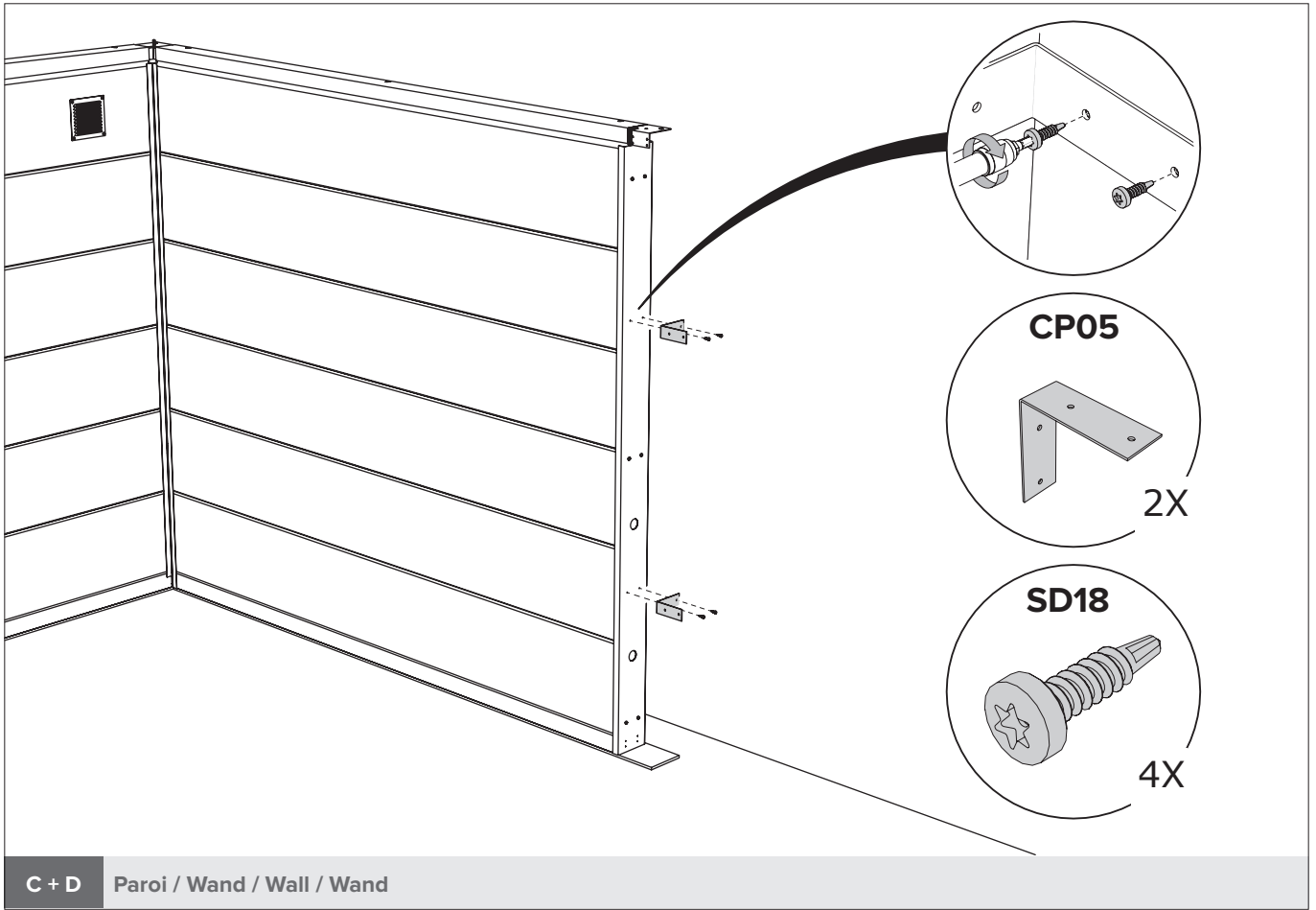

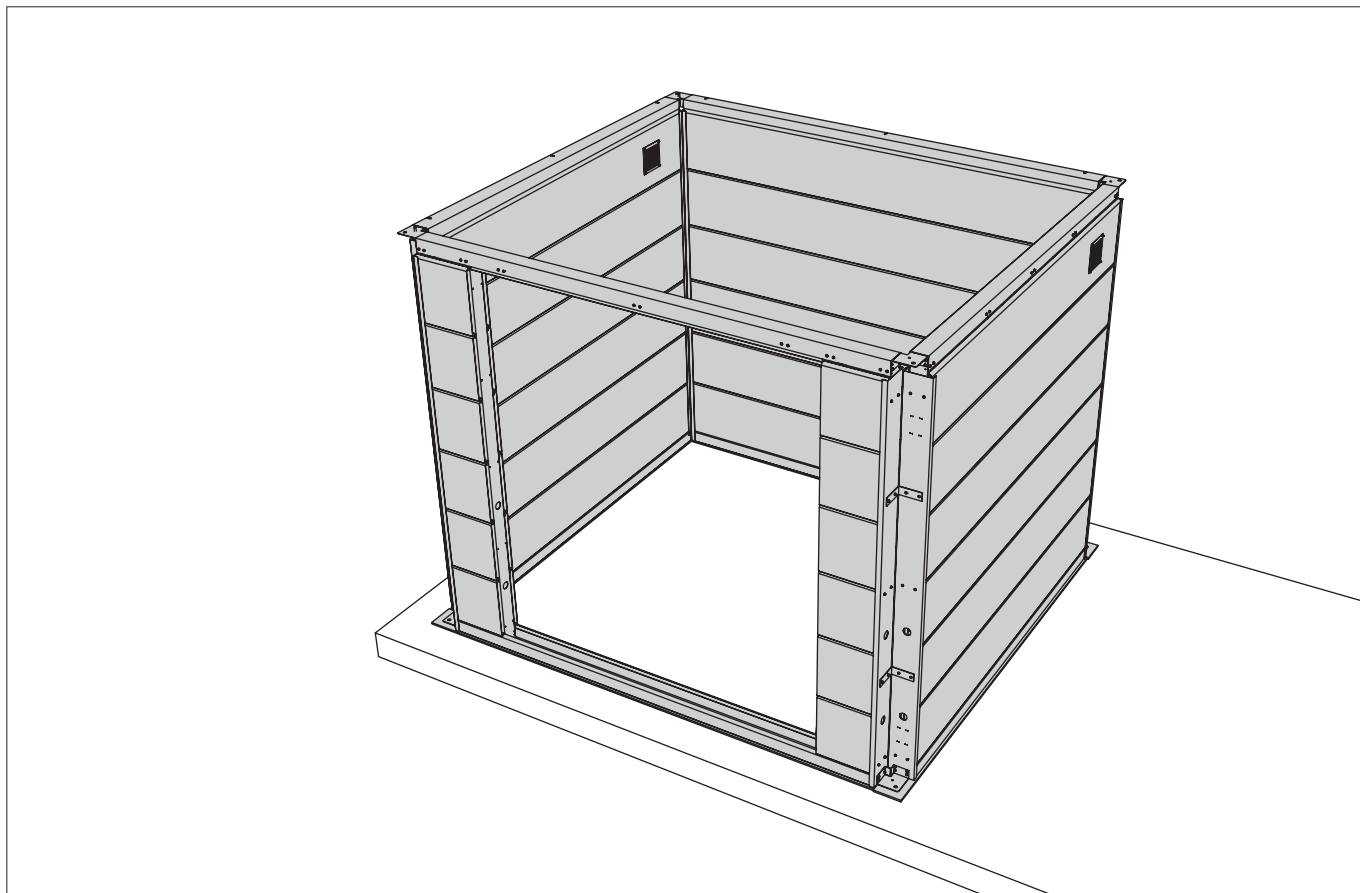

A + B + C + D Paroi / Wand / Wall / Wand

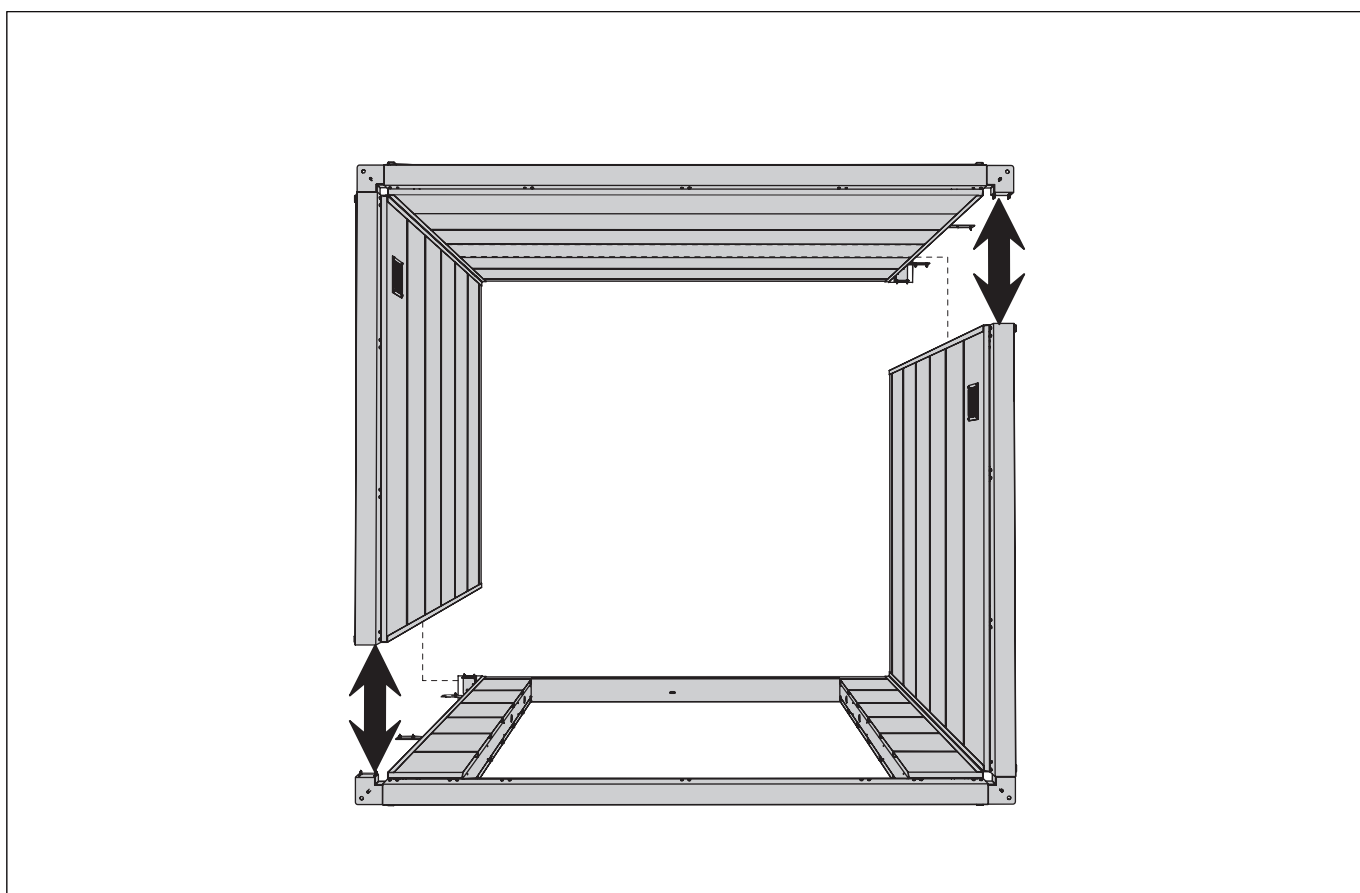

A + B + C + D Paroi / Wand / Wall / Wand

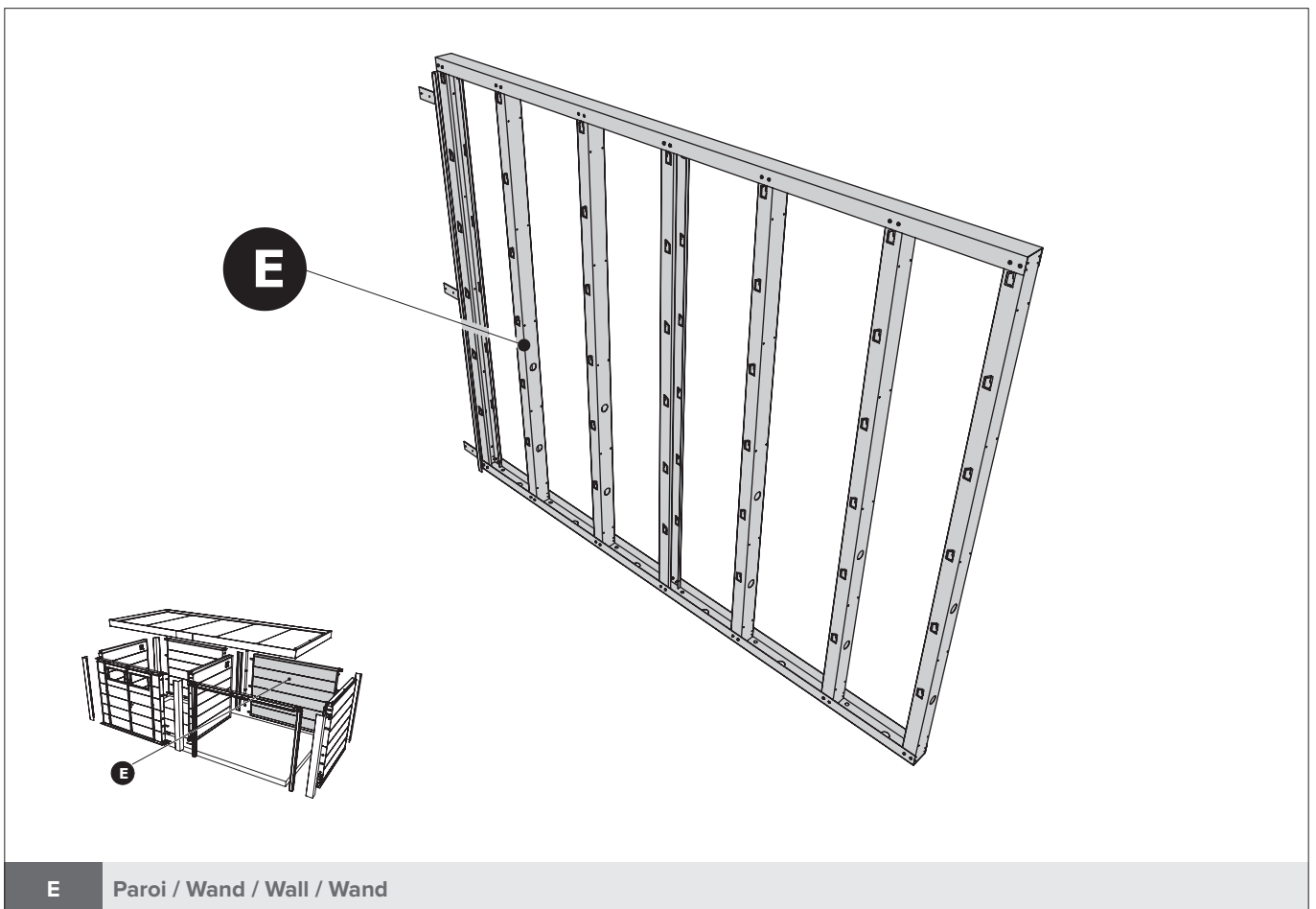
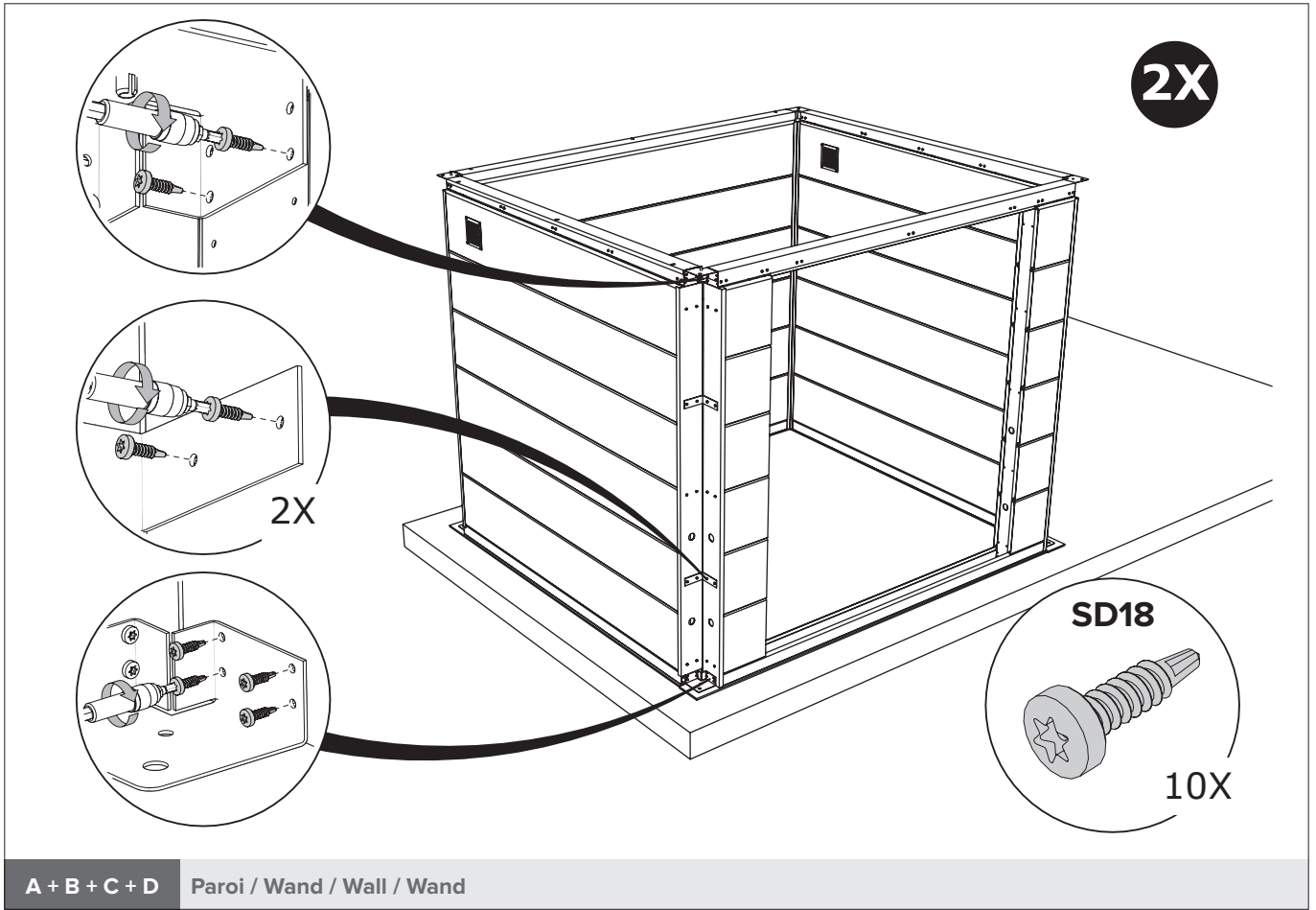

Le principe de la construction du mur, voir pages 8 à 11.
 Het principe van de opbouw van de wand, zie pagina 8 tot en met 11.
 The principle of building the wall, see pages 8 through 11.
 Das Prinzip des Baus der Mauer finden Sie auf den Seiten 8 bis 11.

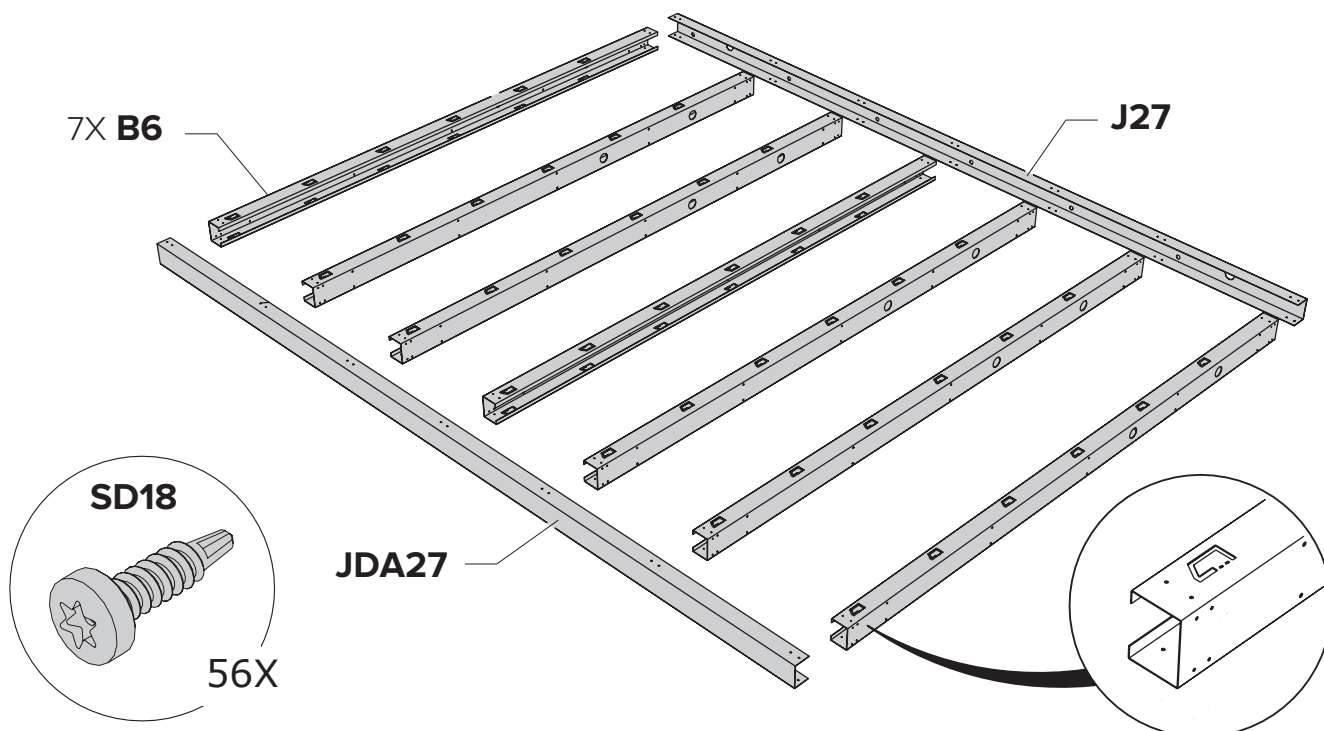

E Paroi / Wand / Wall / Wand

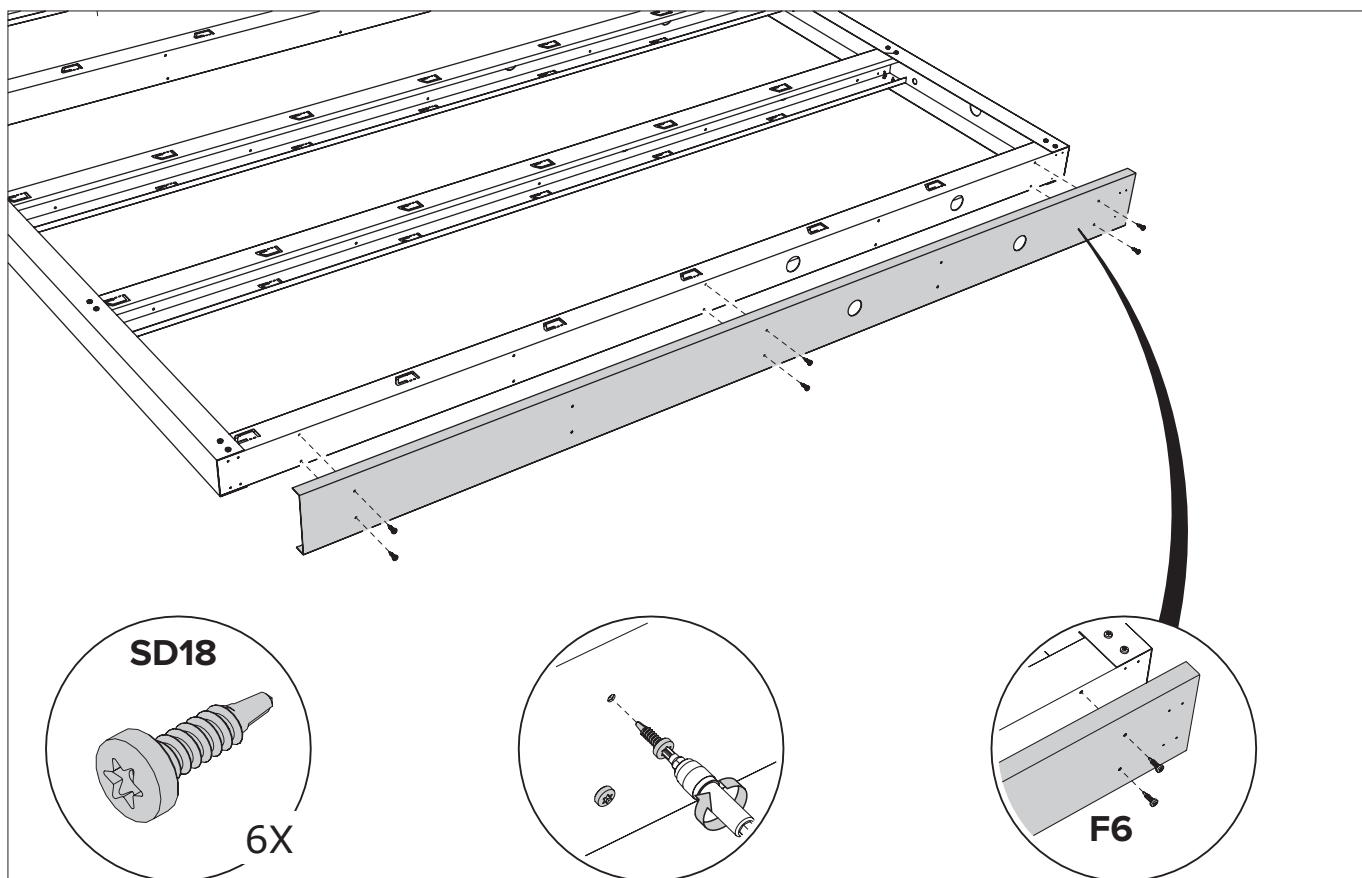

E Paroi / Wand / Wall / Wand

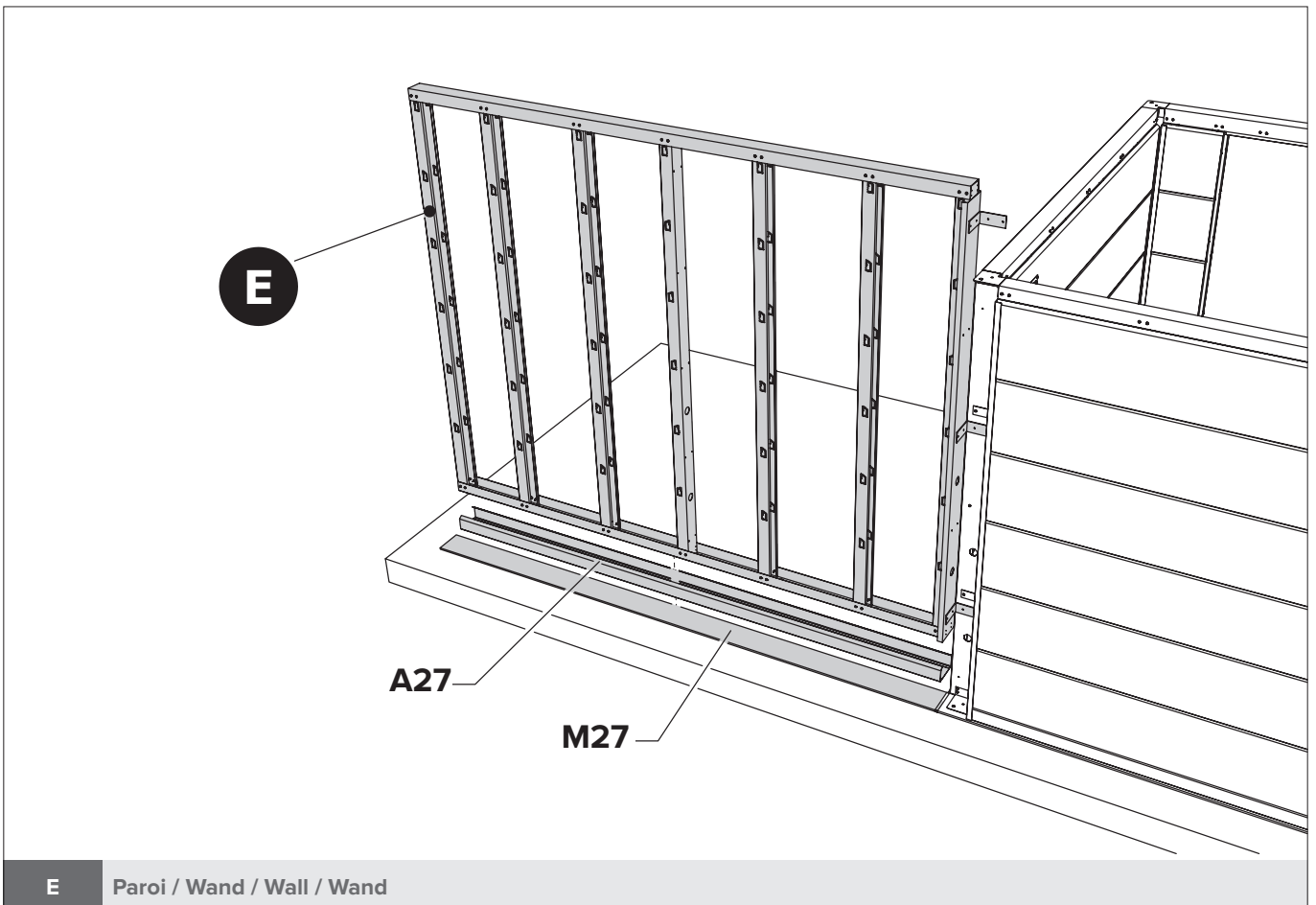
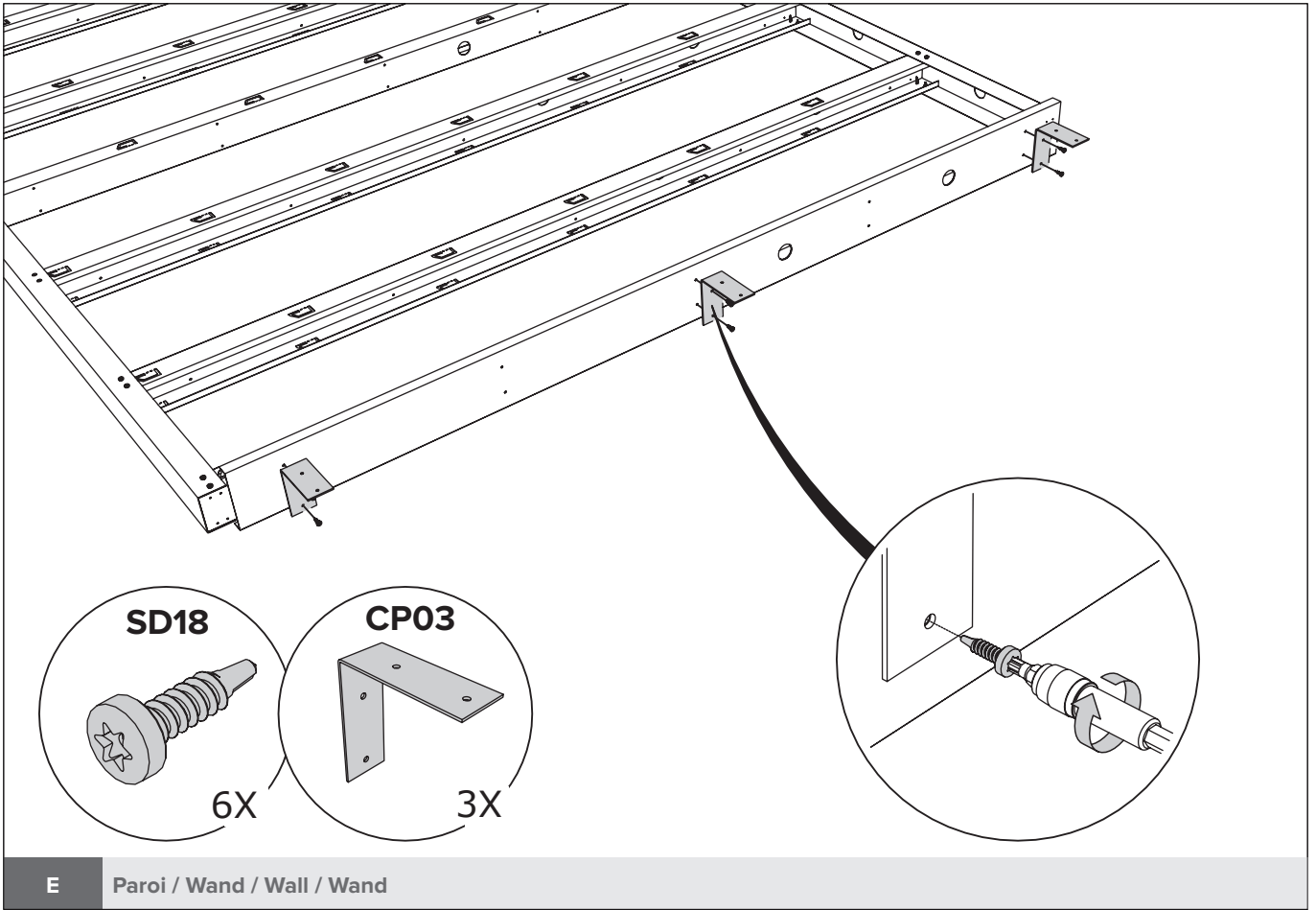

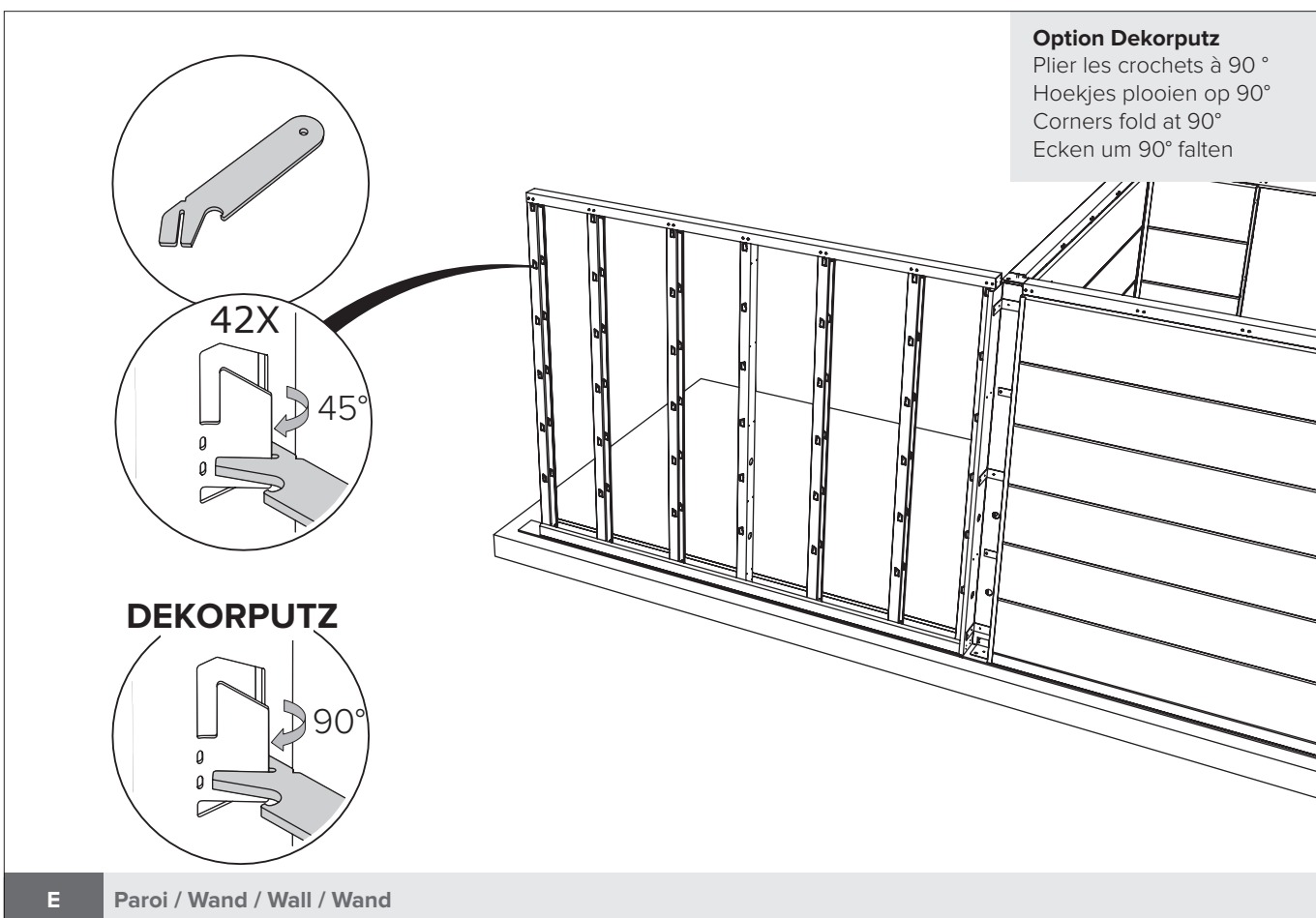
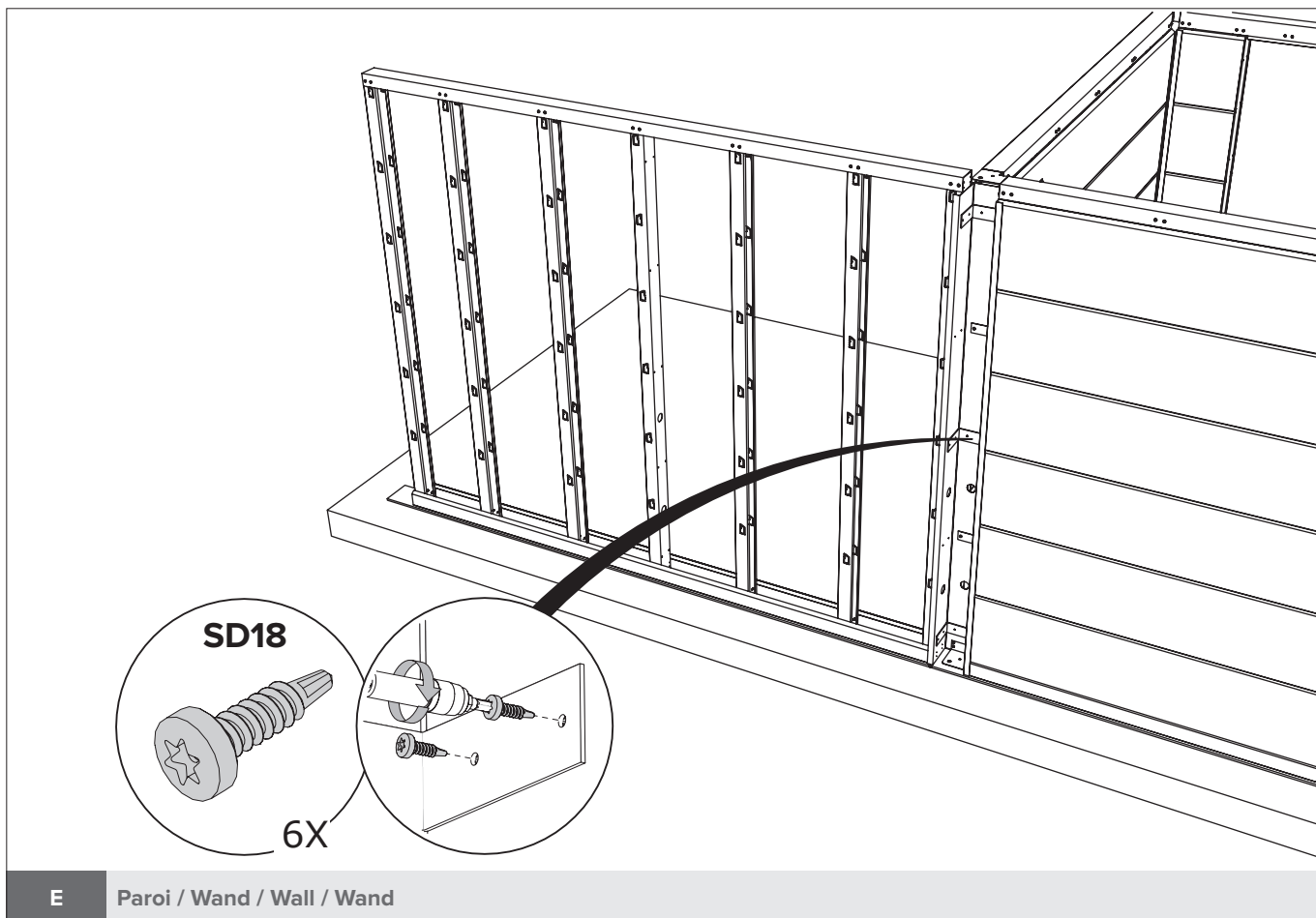

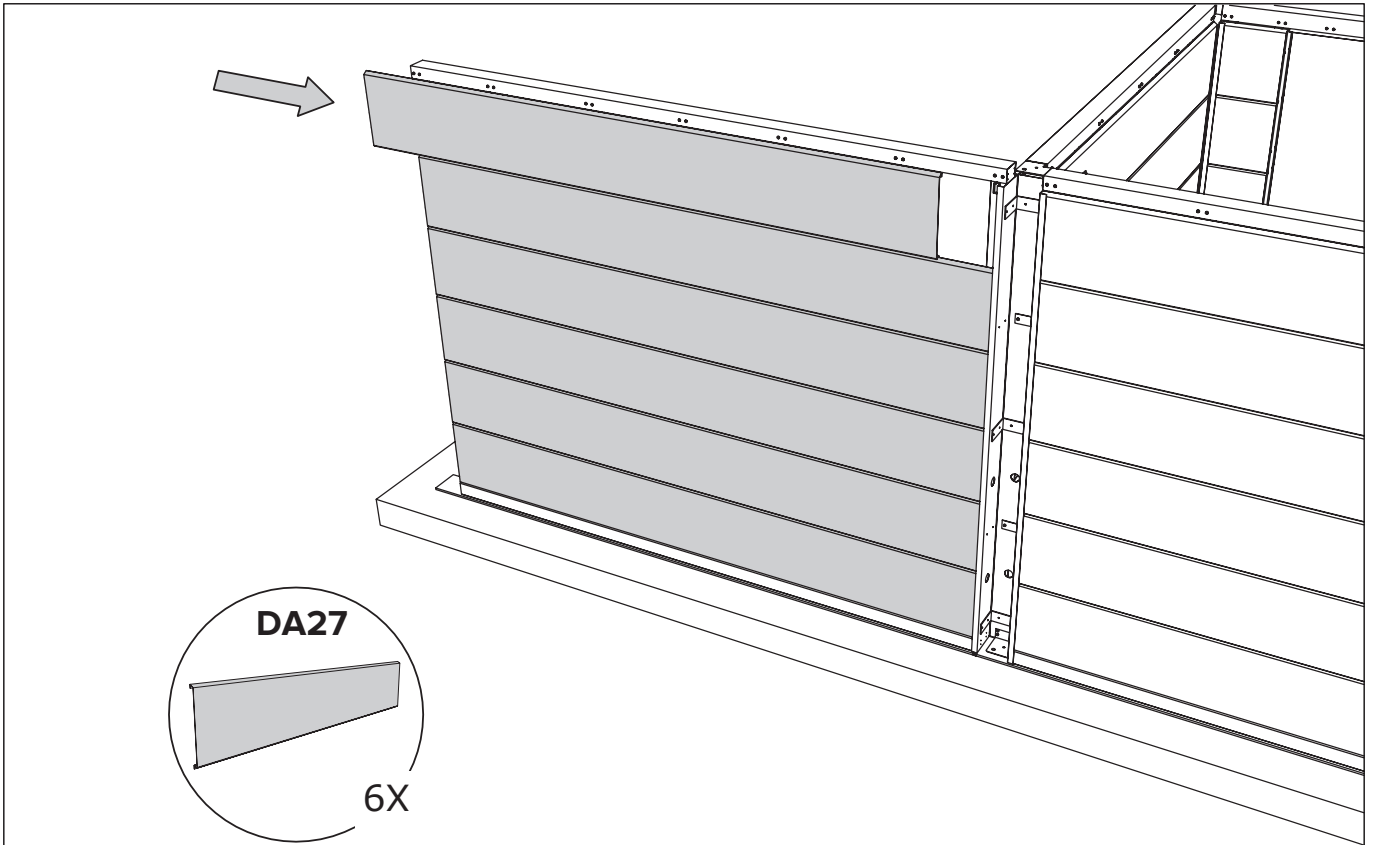

E Paroi / Wand / Wall / Wand

Option Dekorputz

Plier les crochets à 90°
 Hoekjes plooiën op 90°
 Corners fold at 90°
 Ecken um 90° falten

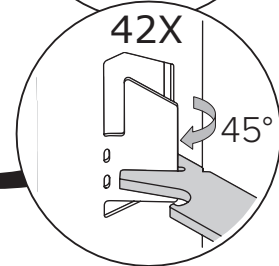
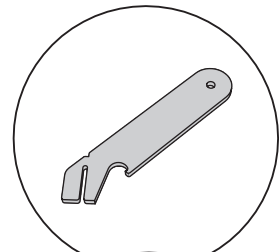
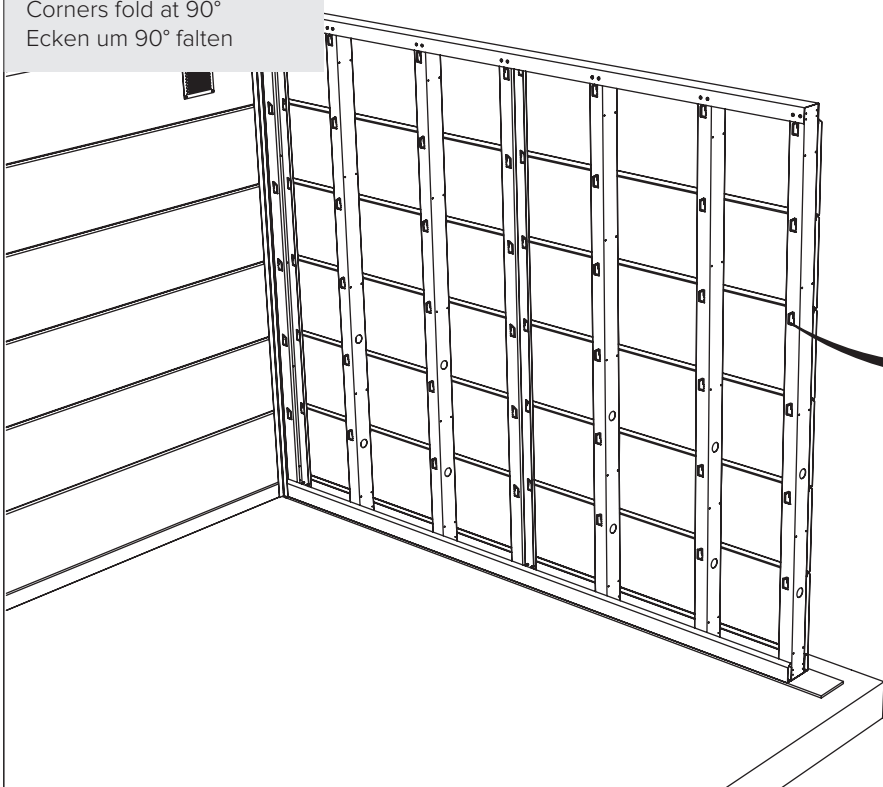

DEKORPUTZ

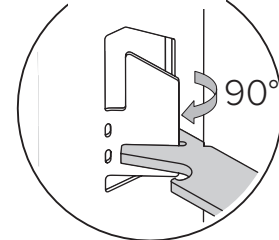

E Paroi / Wand / Wall / Wand

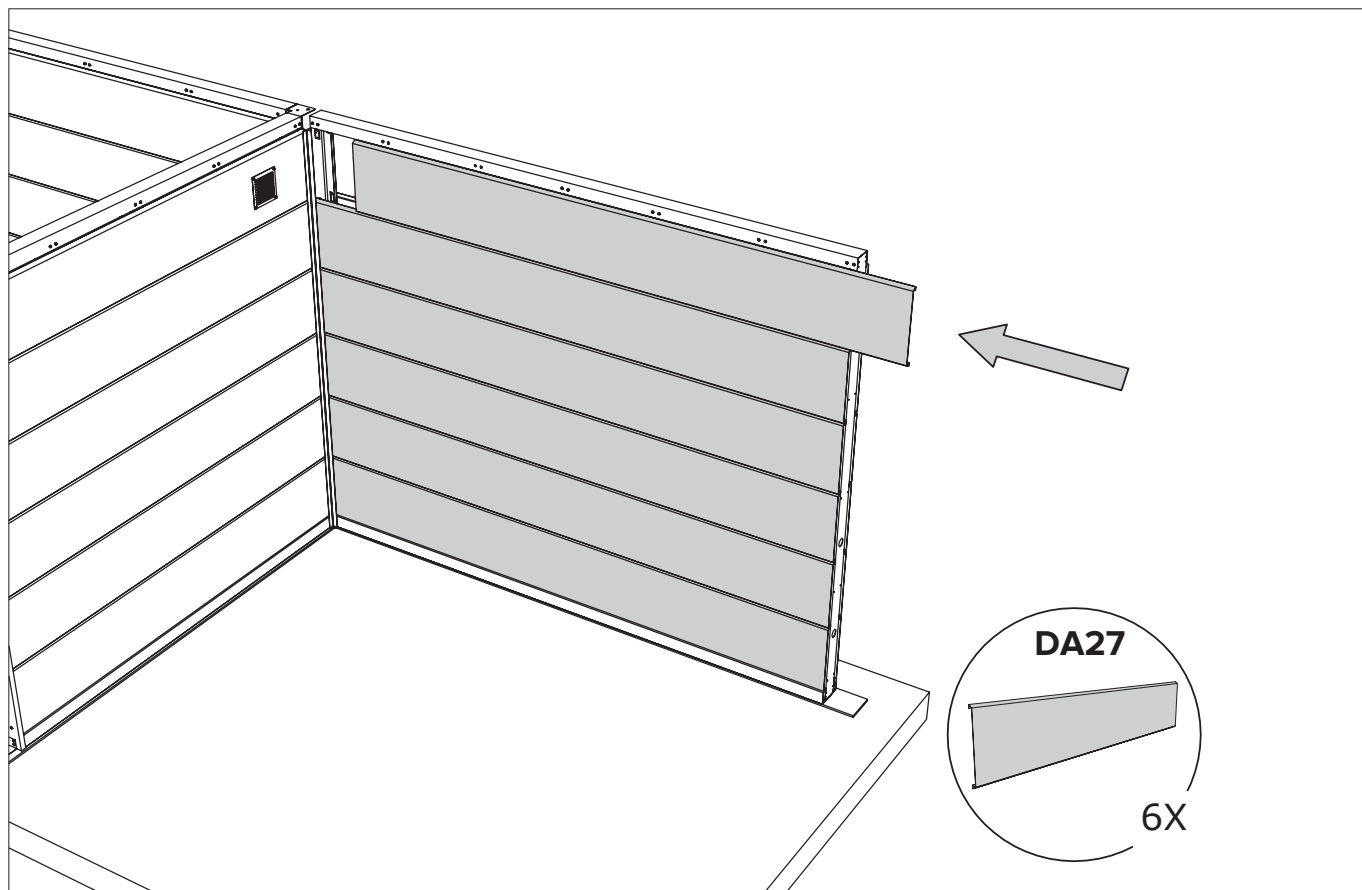

E Paroi / Wand / Wall / Wand

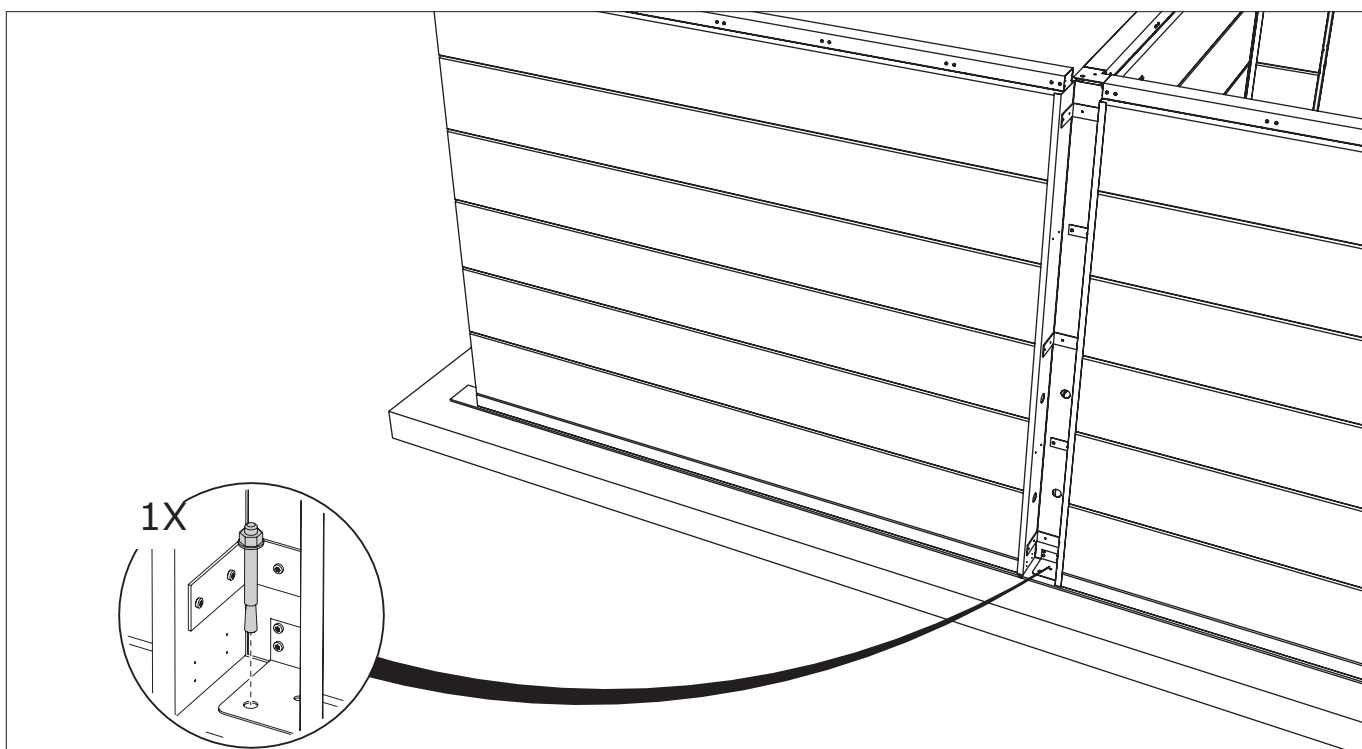

Exemple donné pour un sous-sol en béton. Fixer l'abri de jardin dans les règles de l'art.
 Voorbeeld is voor beton-ondergrond. Tuinhuisje fixeren volgens de regels van de kunst.
 Example is for concrete substrate. Fix the garden shed in accordance with good practise.
 Beispiel ist für Betonuntergrund. Fachgerechte Befestigung des Gartenhäuschens.

E Paroi / Wand / Wall / Wand

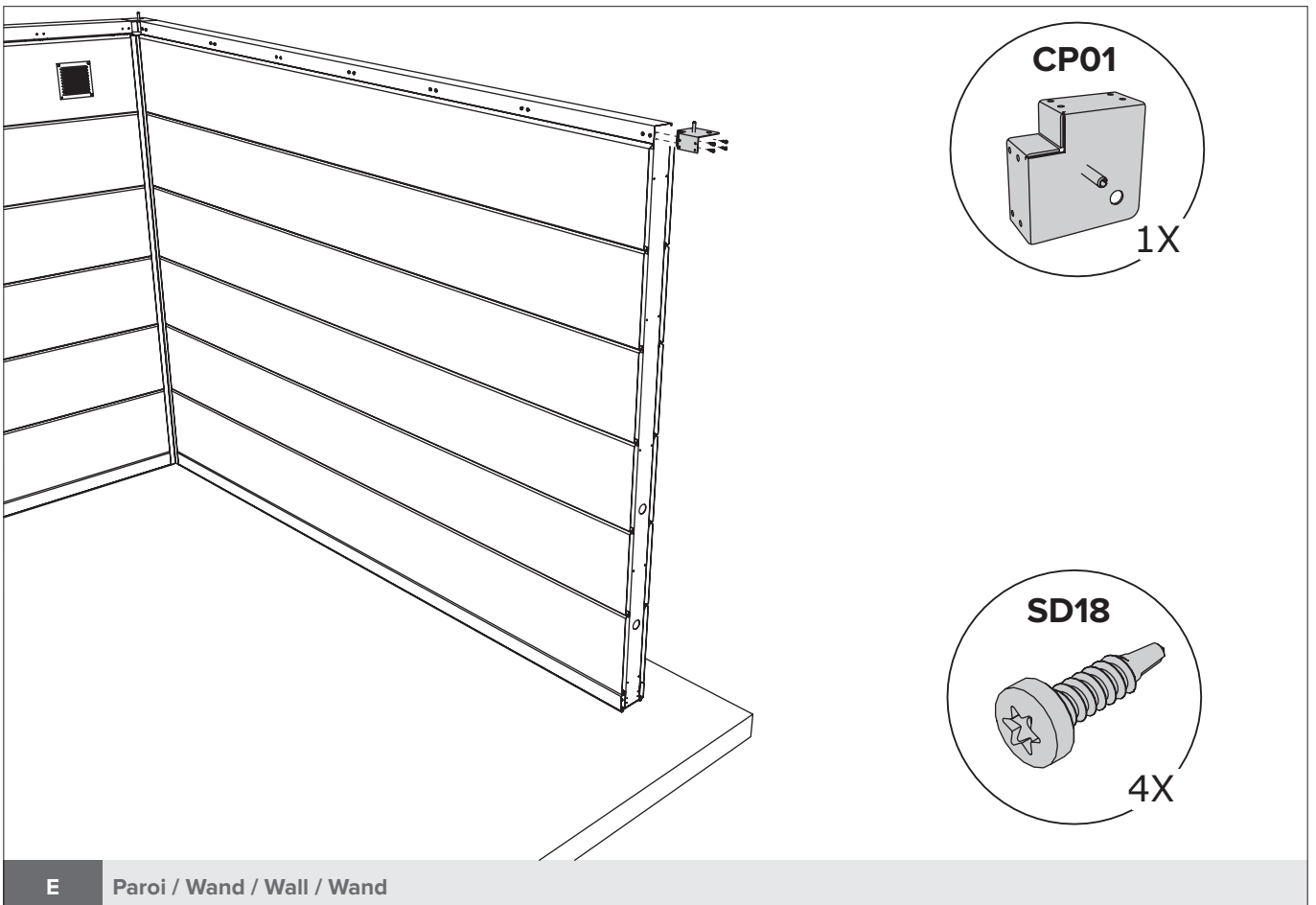
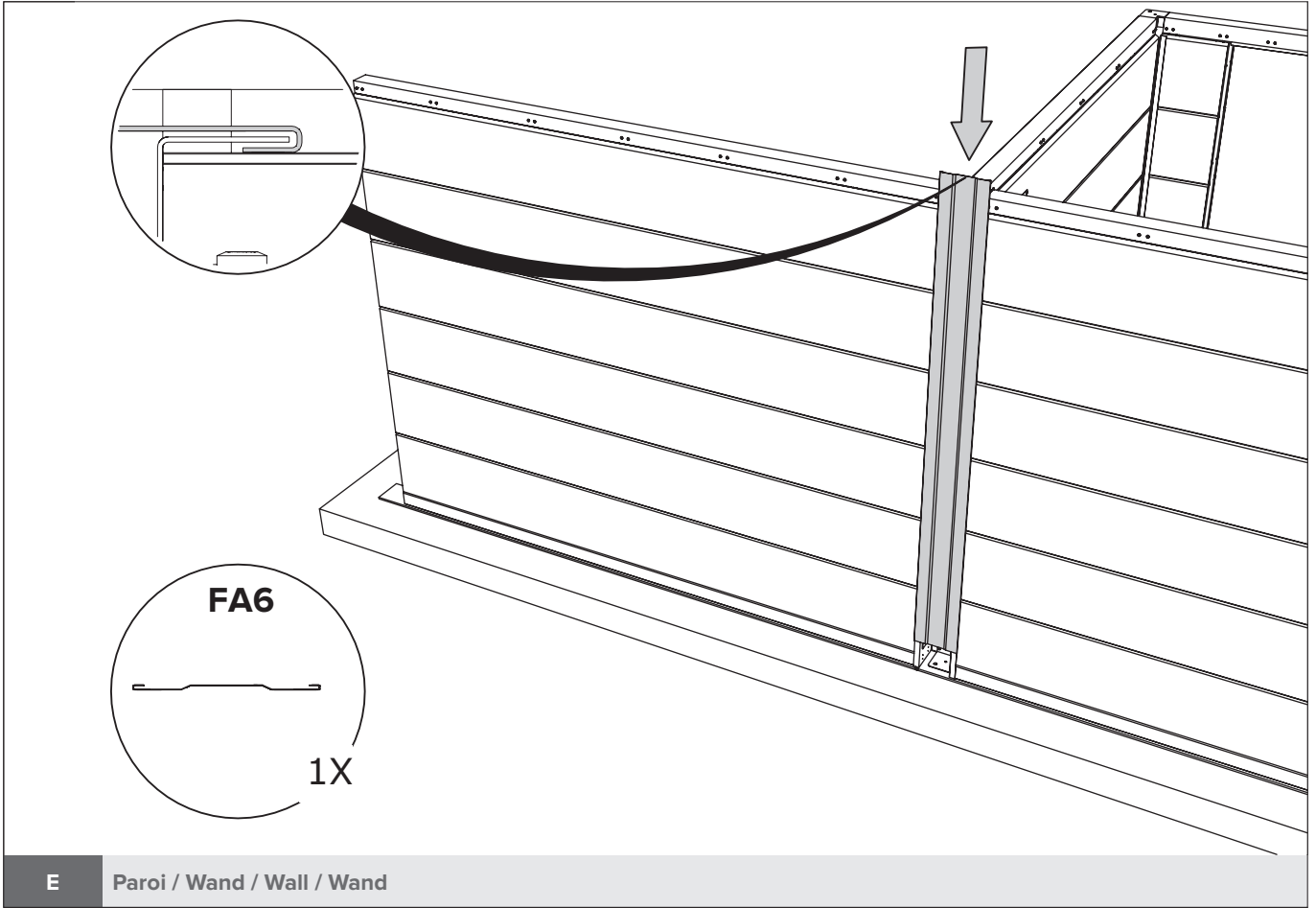

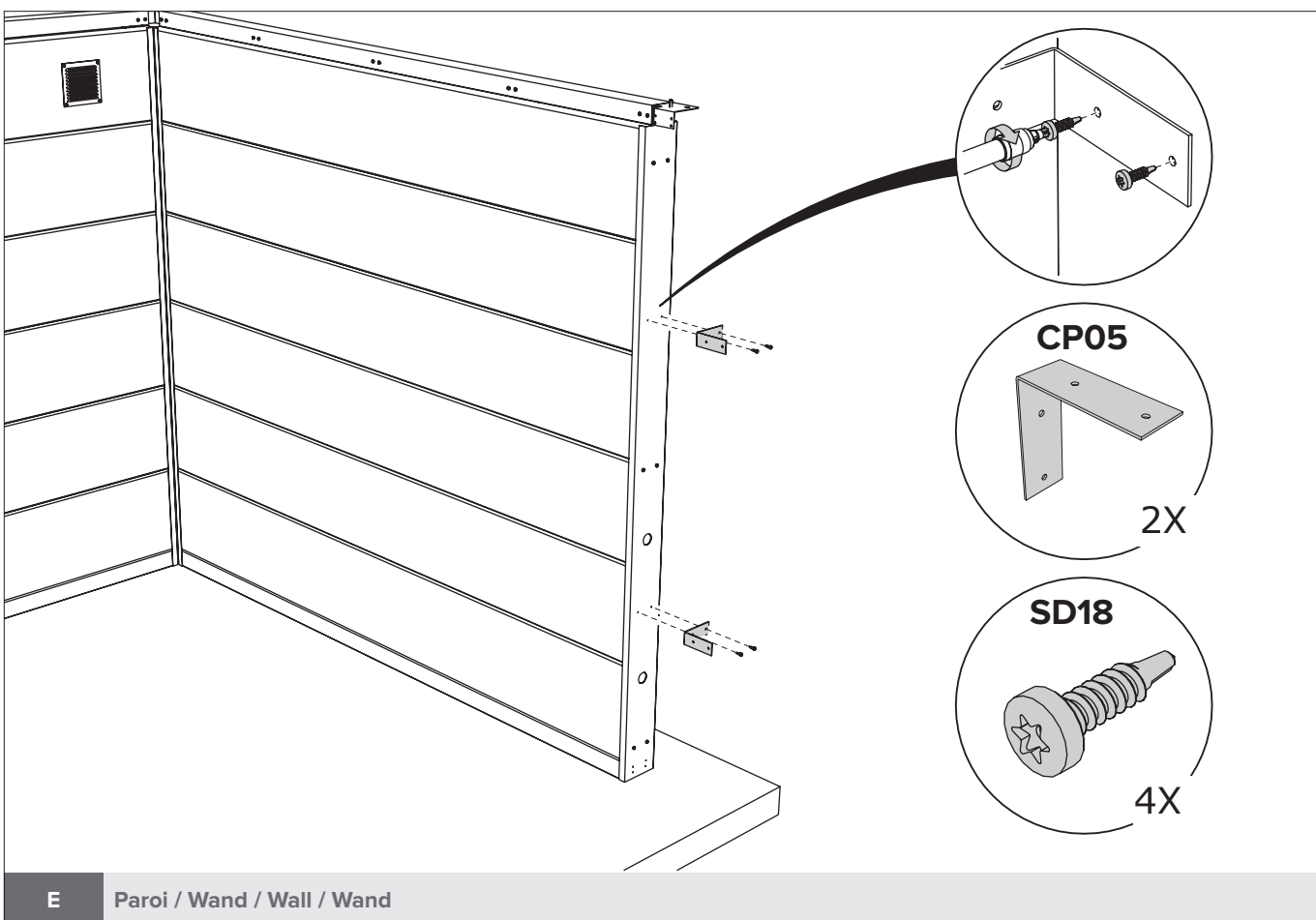
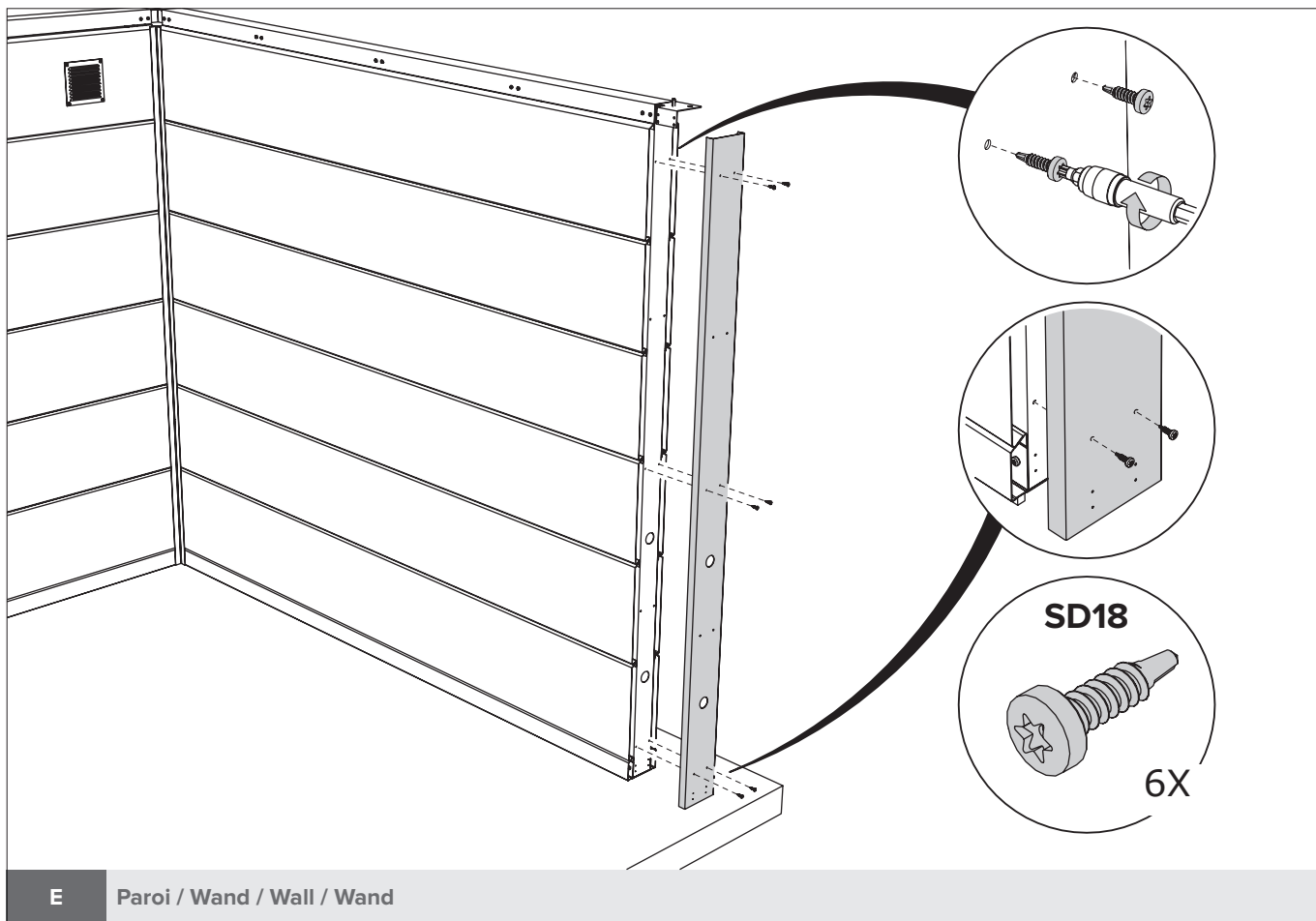

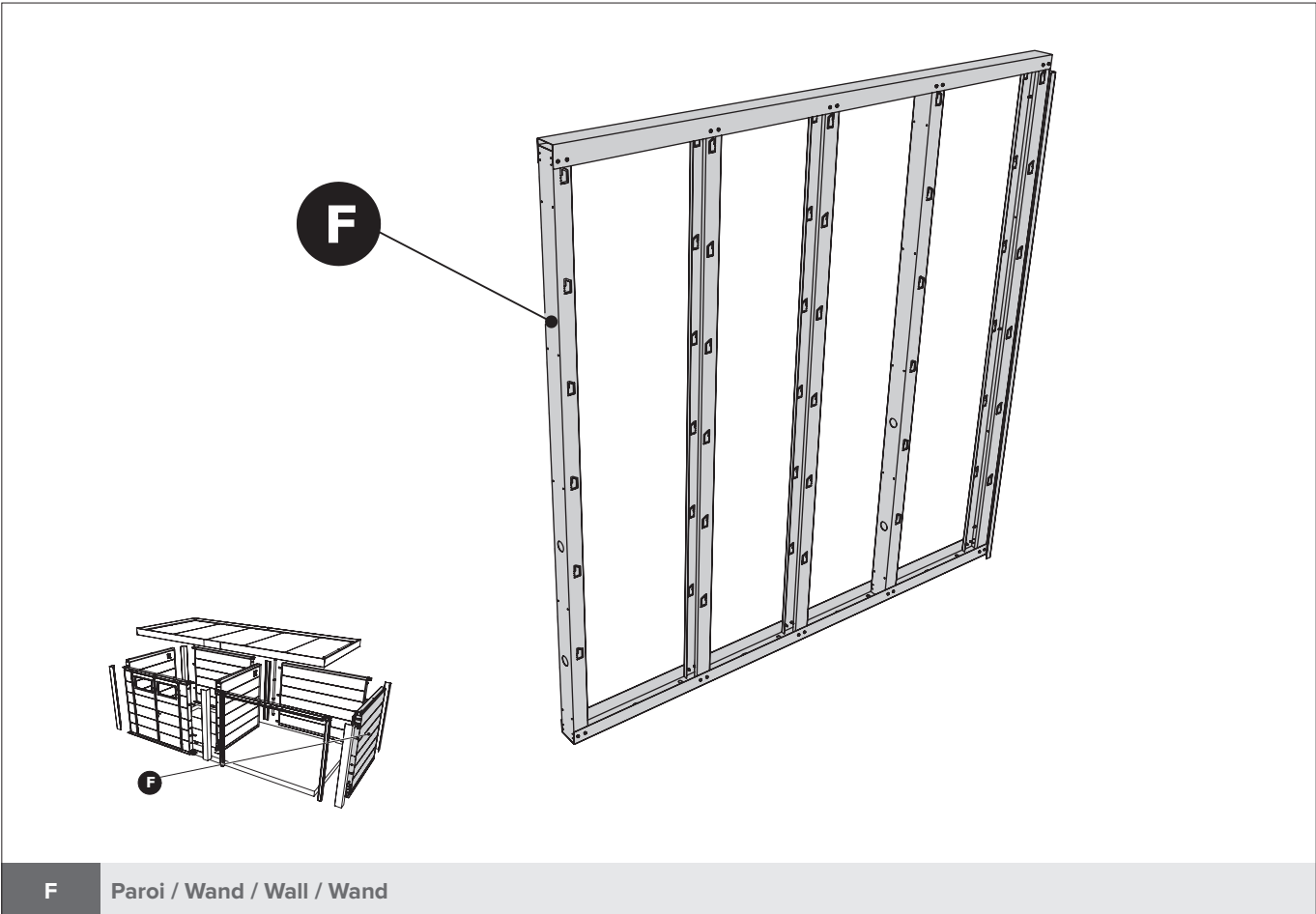
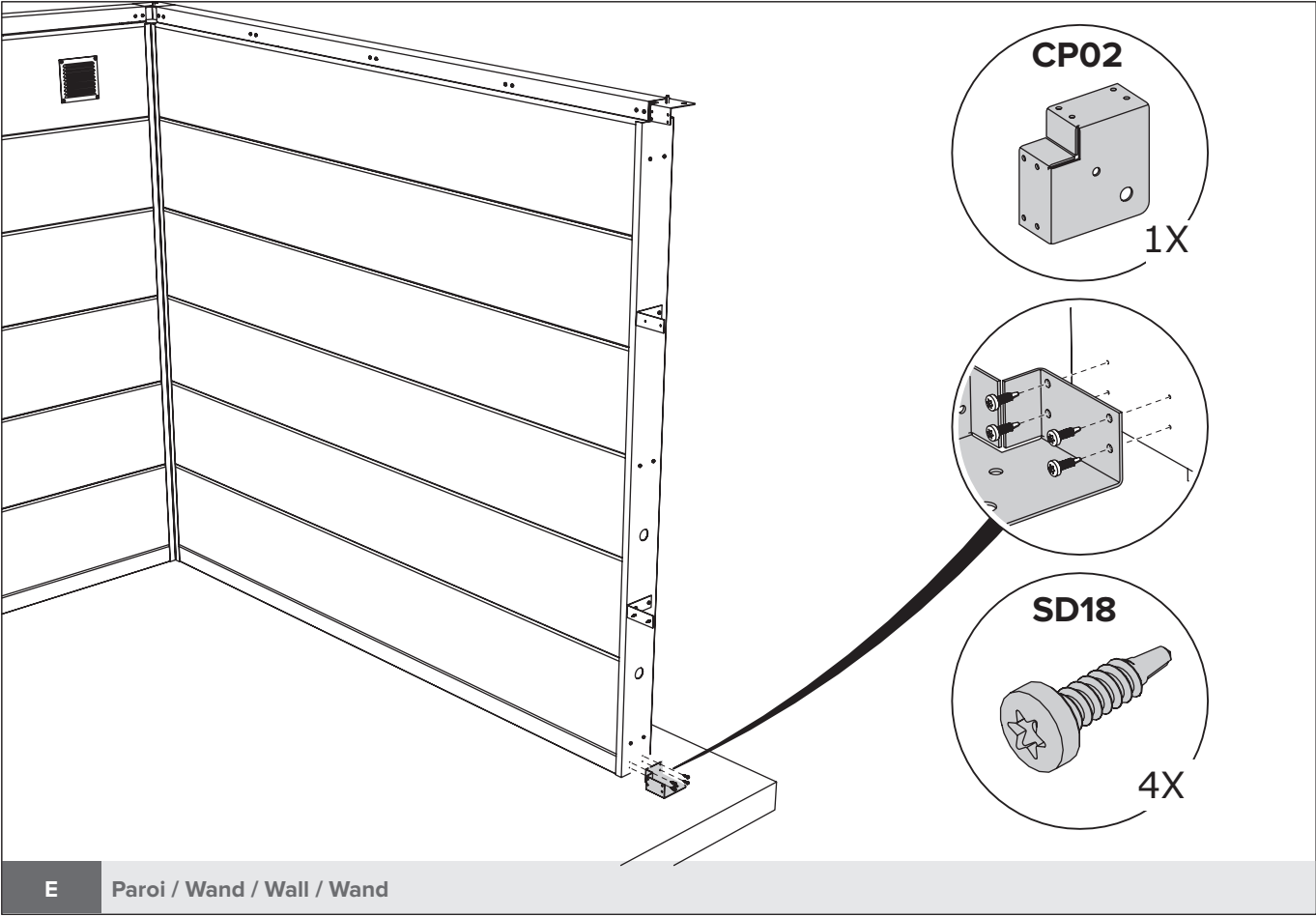

Le principe de la construction du mur, voir pages 8 à 11.
 Het principe van de opbouw van de wand, zie pagina 8 tot en met 11.
 The principle of building the wall, see pages 8 through 11.
 Das Prinzip des Baus der Mauer finden Sie auf den Seiten 8 bis 11.

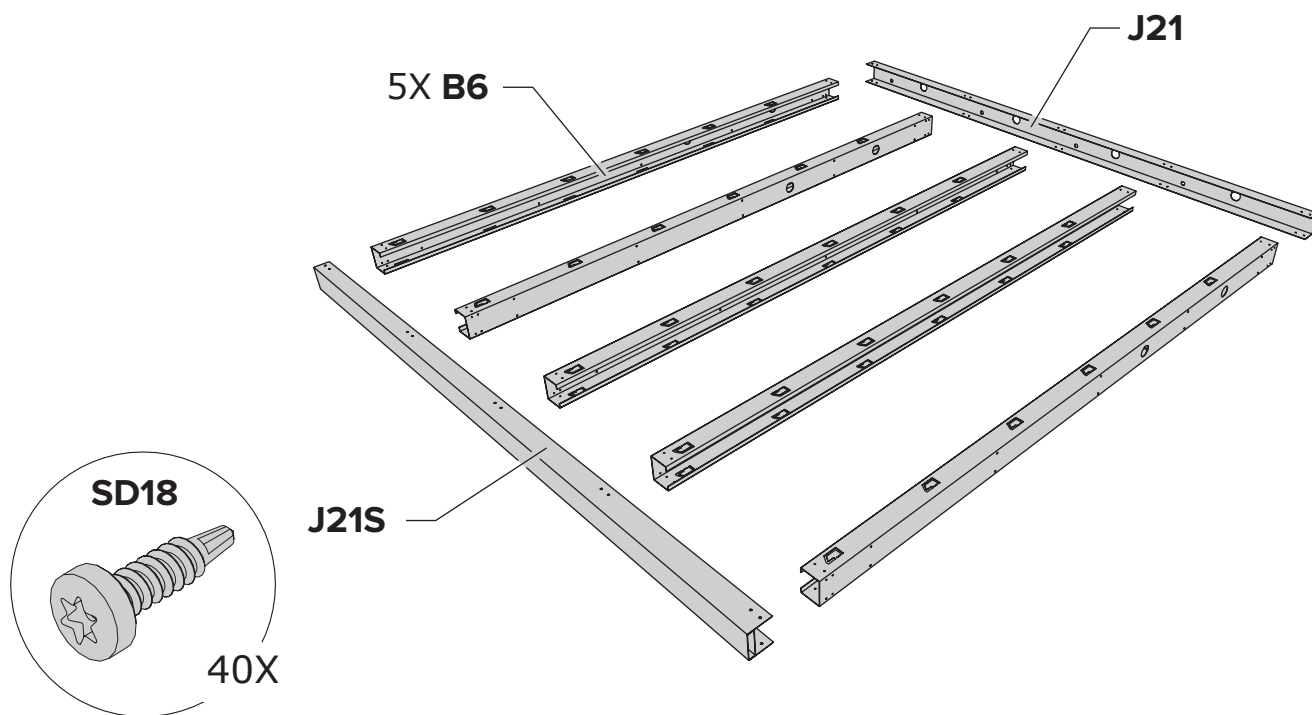

F Paroi / Wand / Wall / Wand

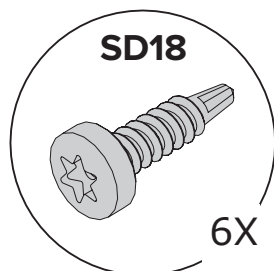
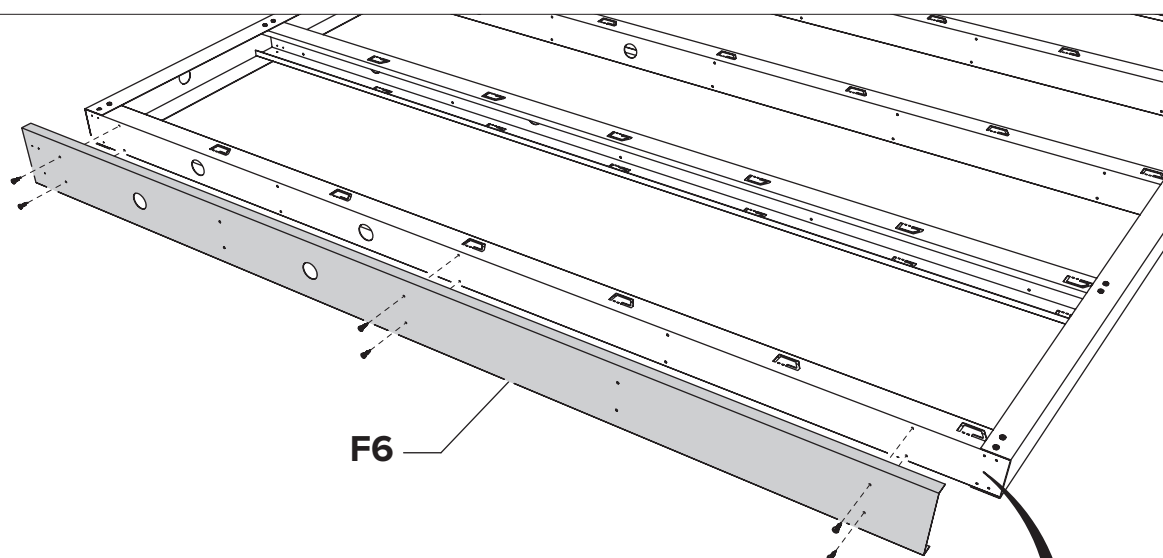

F Paroi / Wand / Wall / Wand

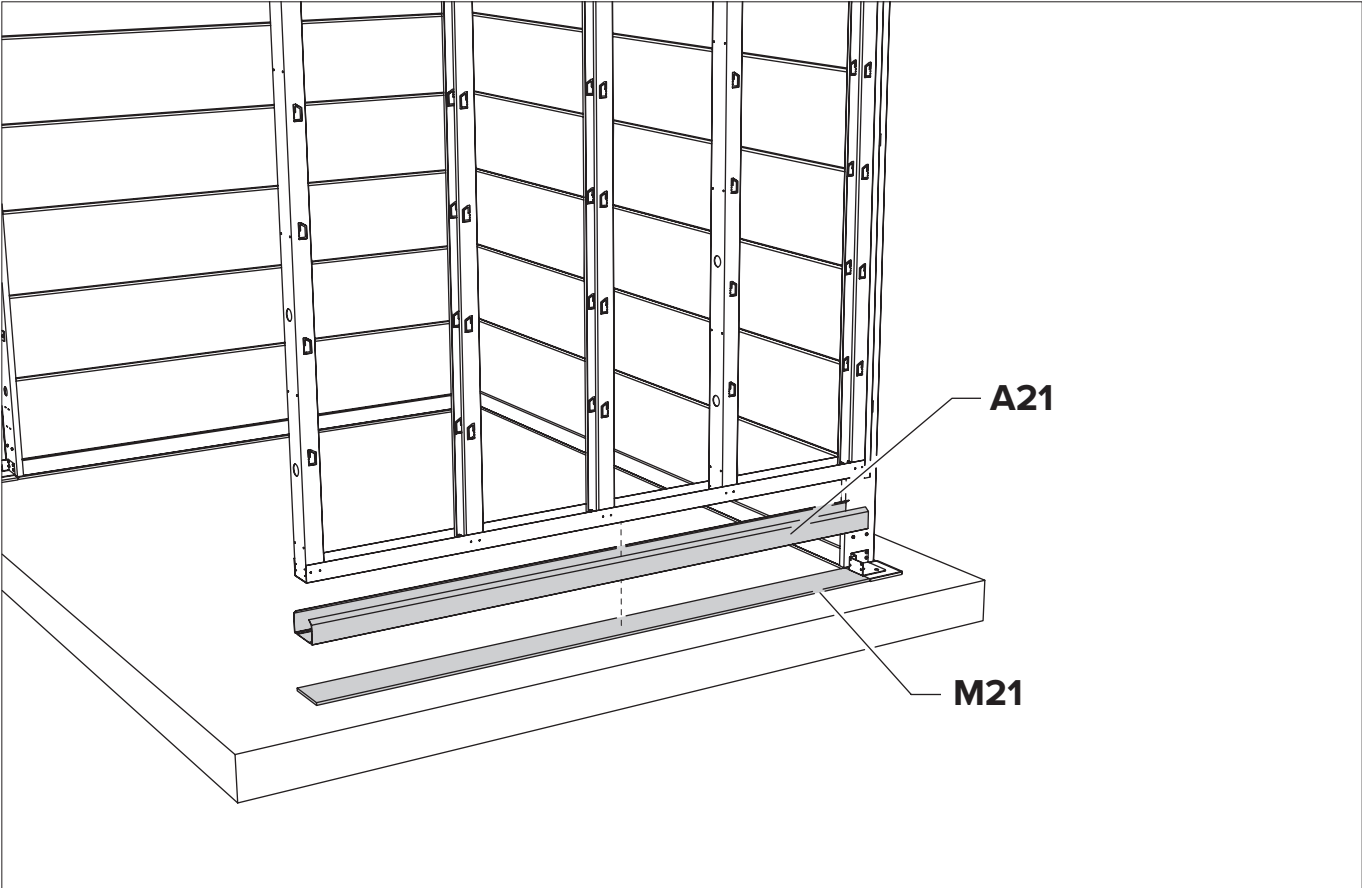

F Paroi / Wand / Wall / Wand

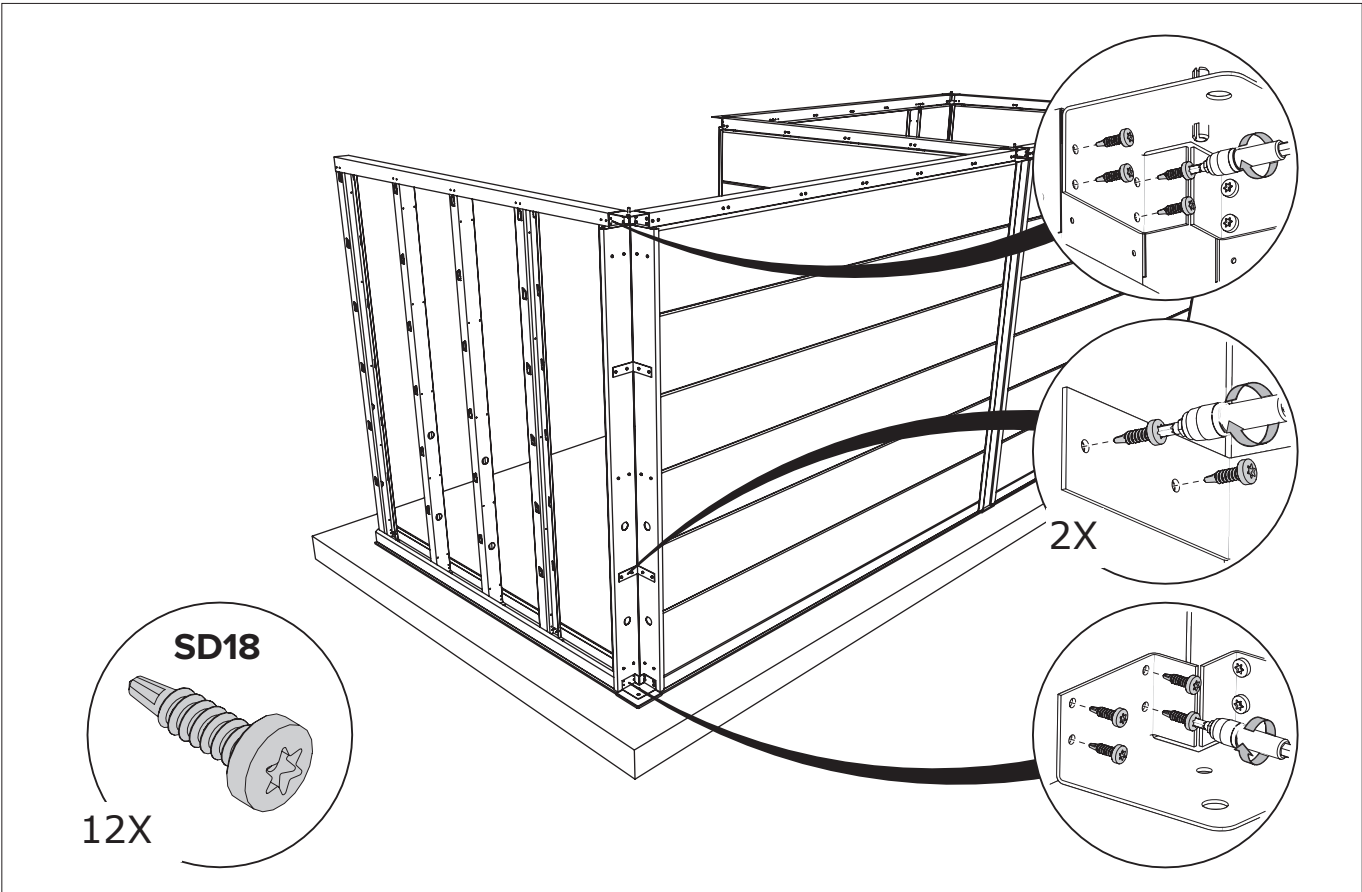

F Paroi / Wand / Wall / Wand

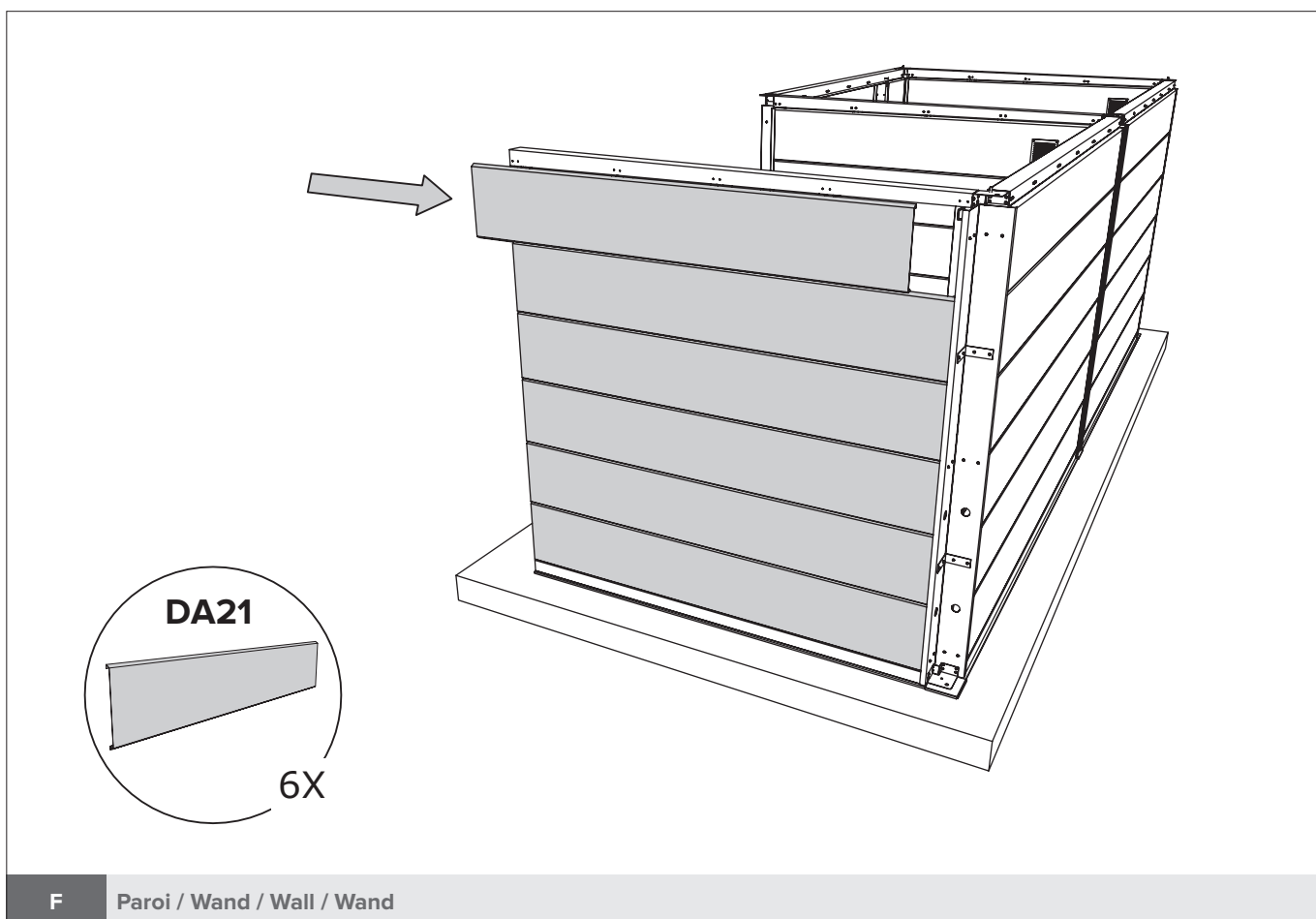
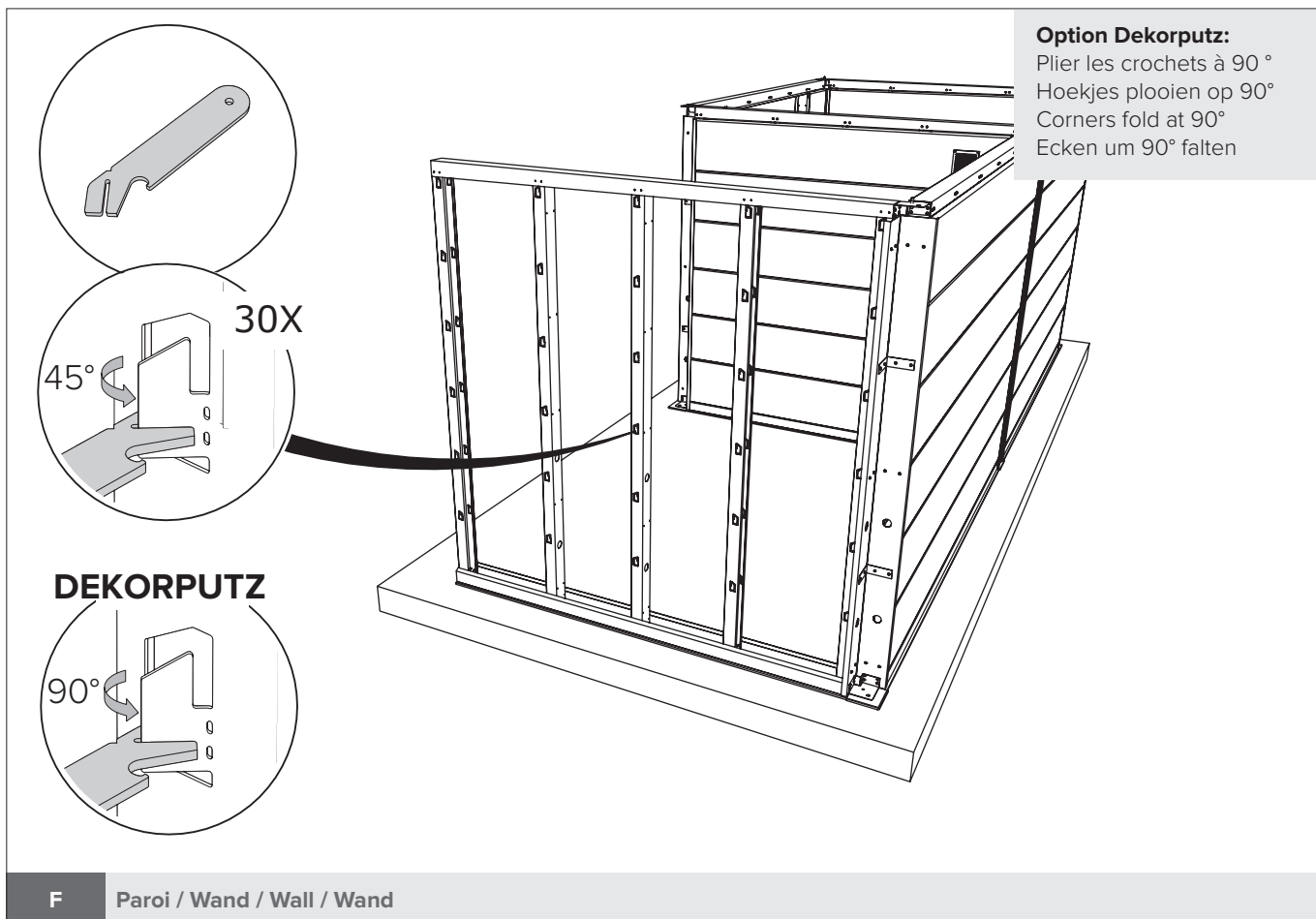

Option Dekorputz:

Plier les crochets à 90 °
 Hoekjes plooiën op 90°
 Corners fold at 90°
 Ecken um 90° falten

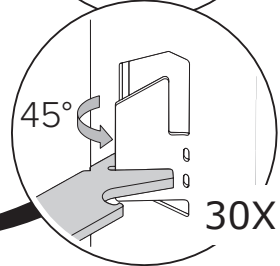
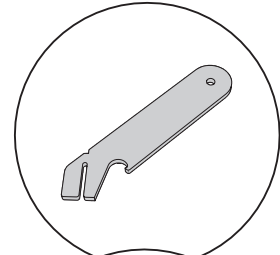
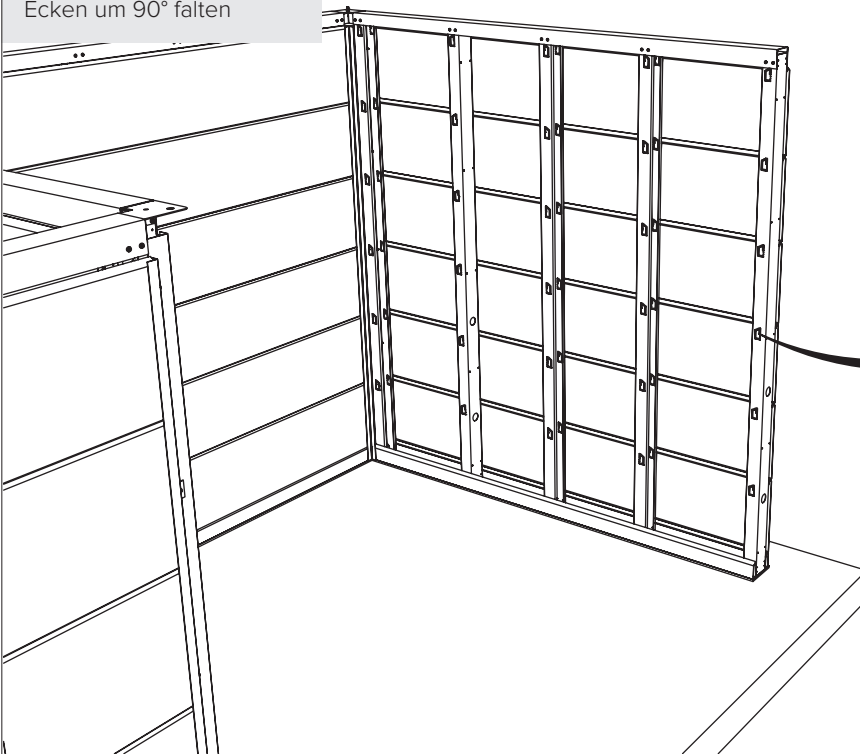

DEKORPUTZ

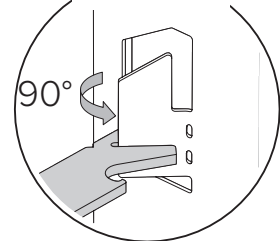

F

Paroi / Wand / Wall / Wand

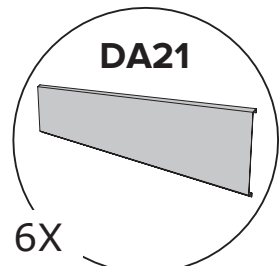
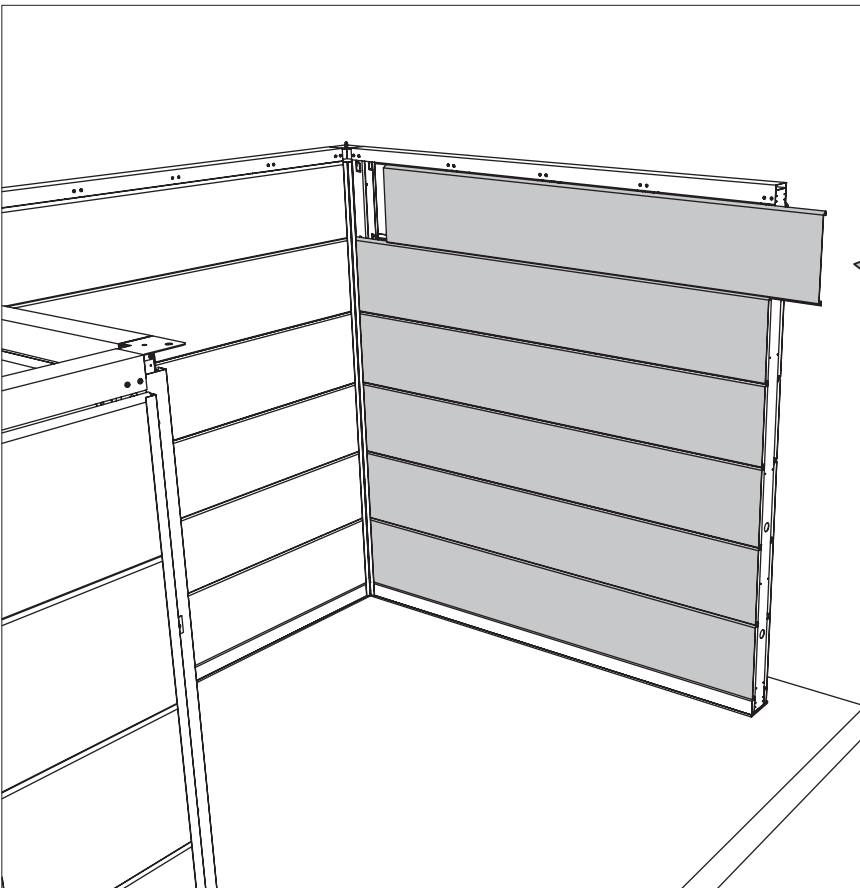

F

Paroi / Wand / Wall / Wand

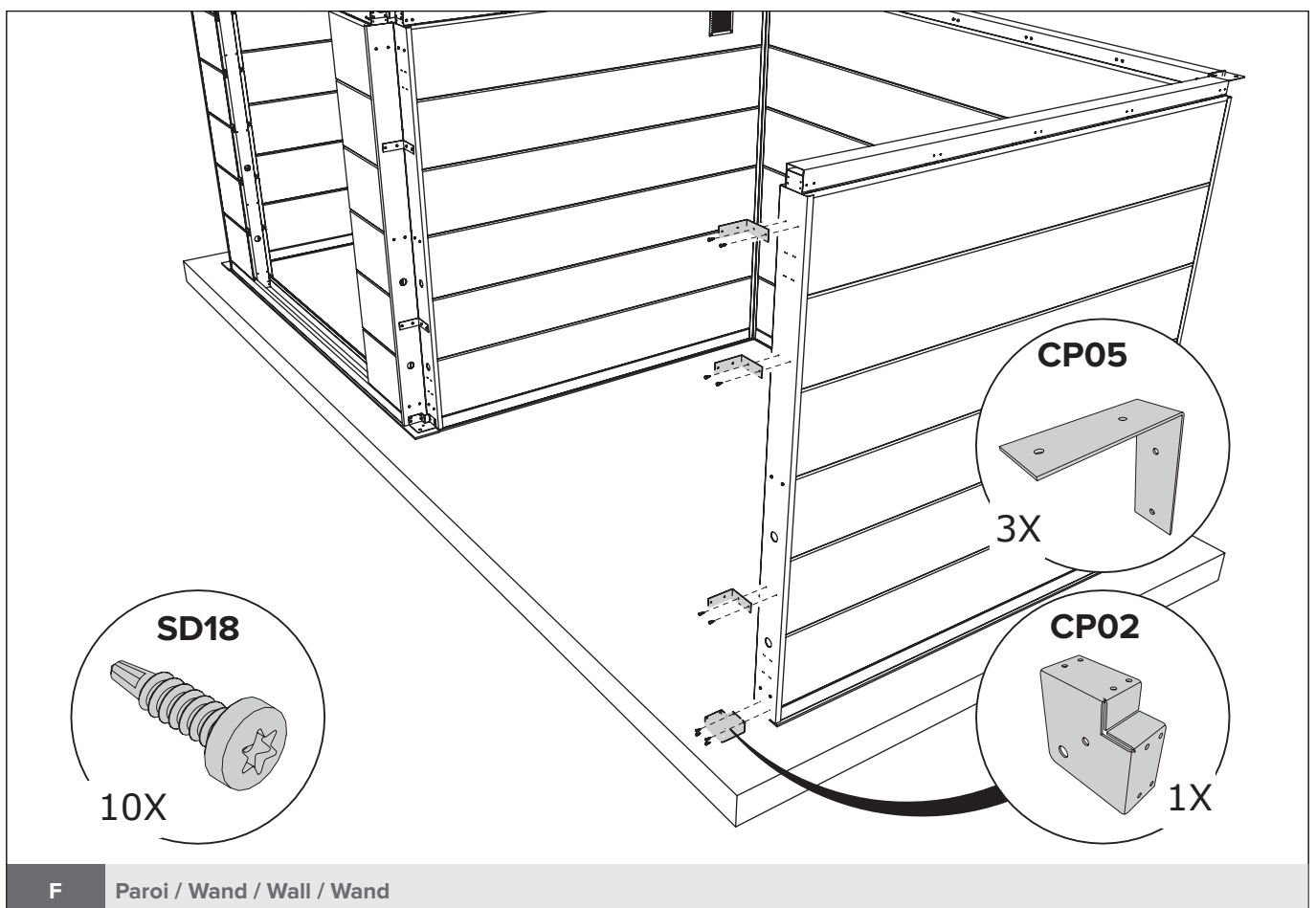
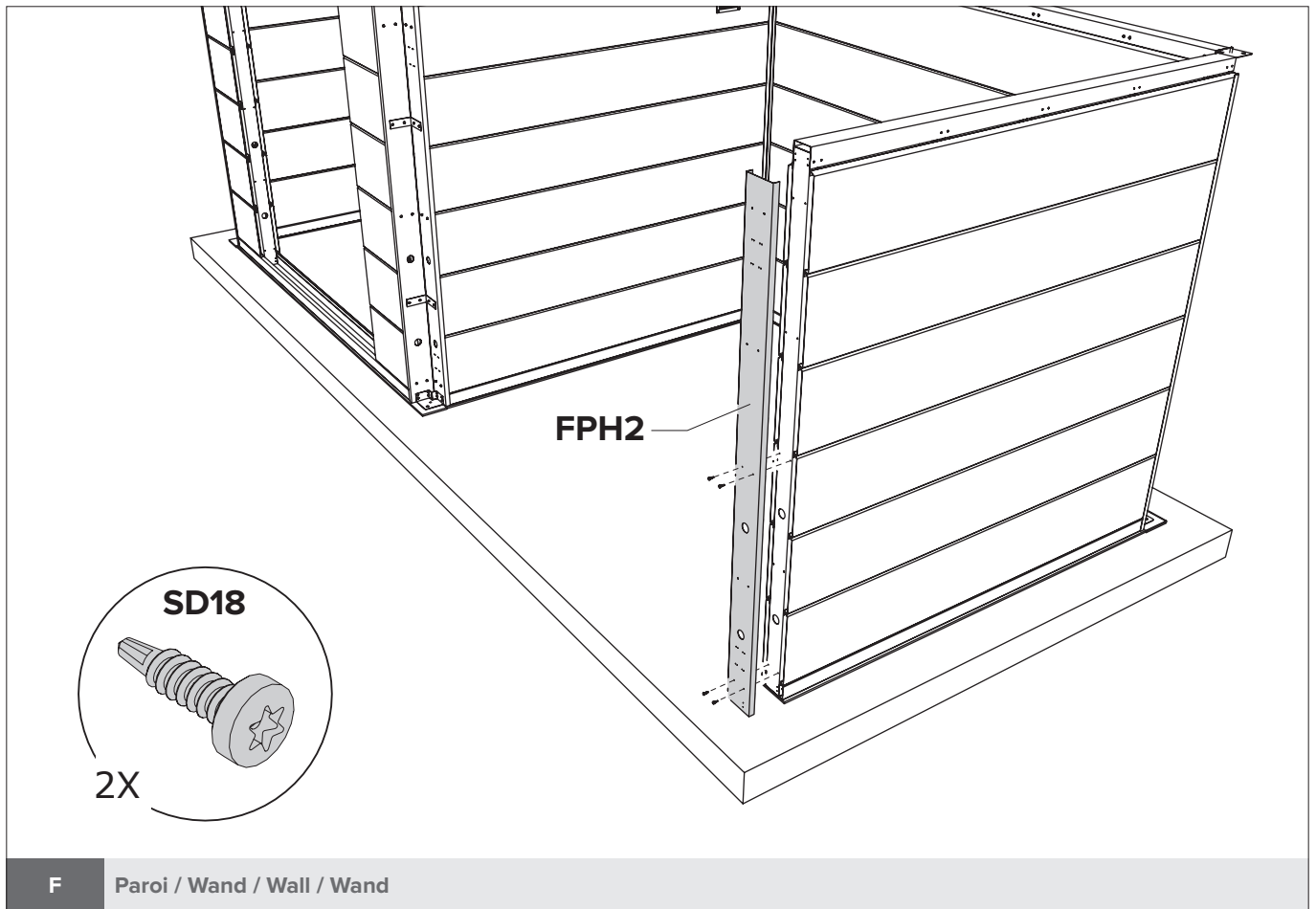

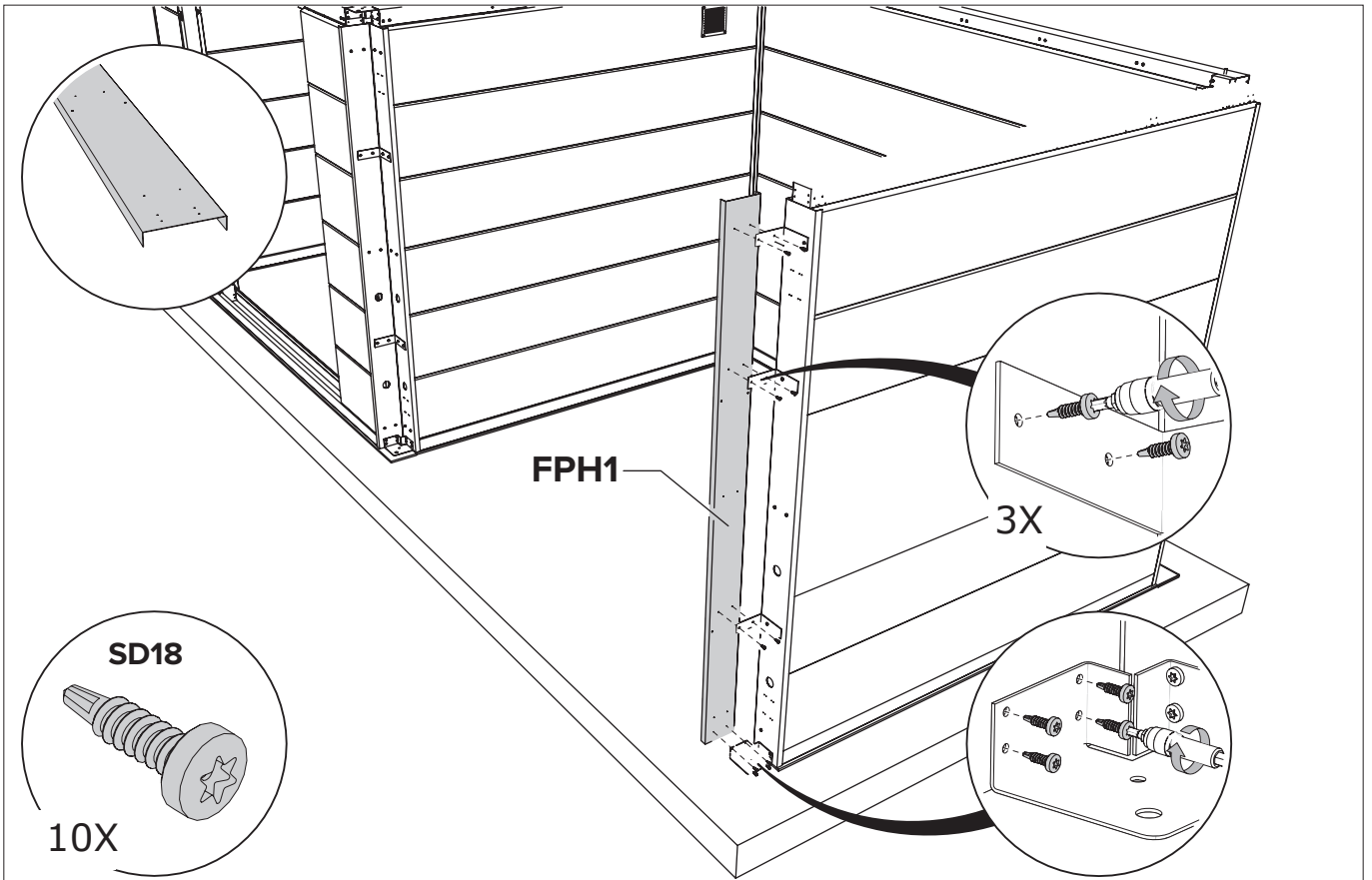

F Paroi / Wand / Wall / Wand

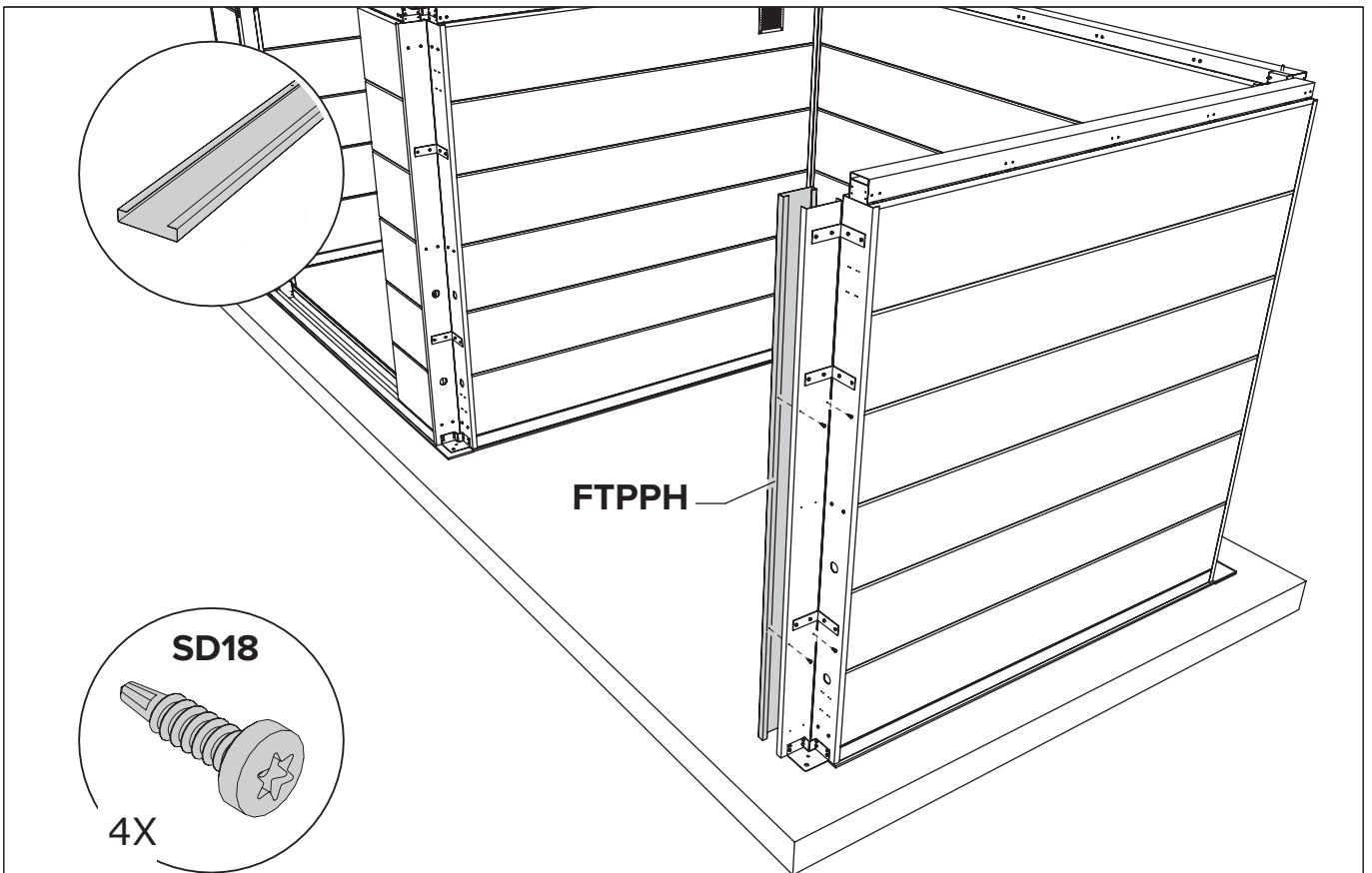

F Paroi / Wand / Wall / Wand

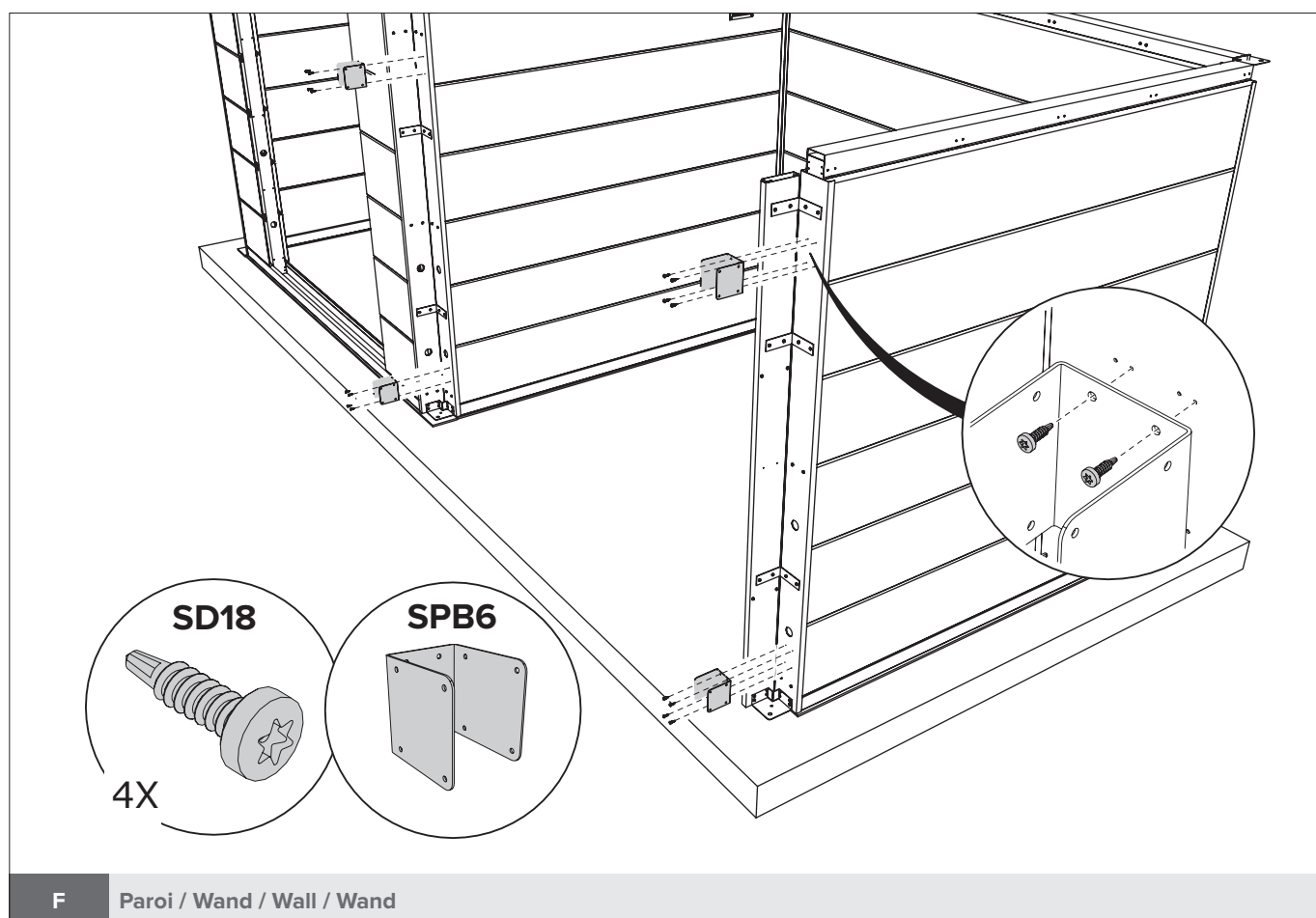
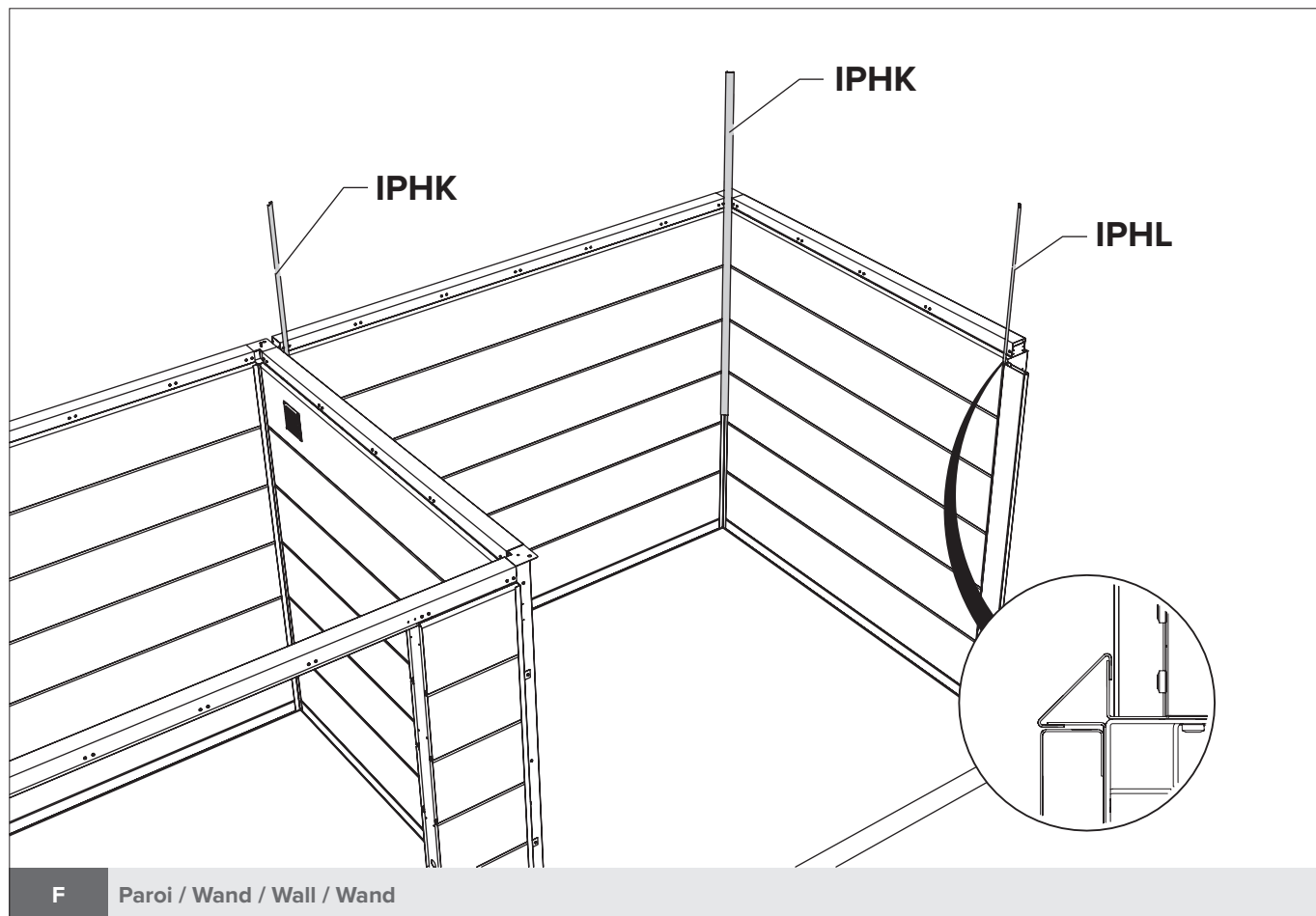

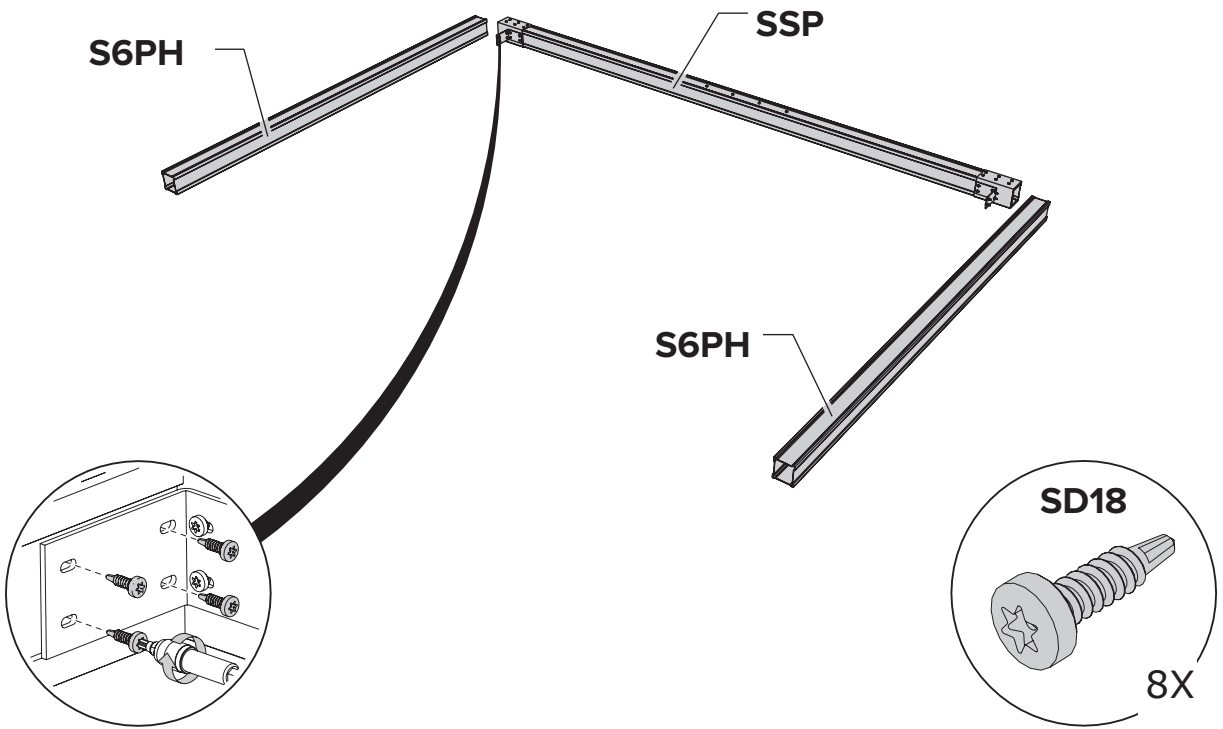

F Paroi / Wand / Wall / Wand

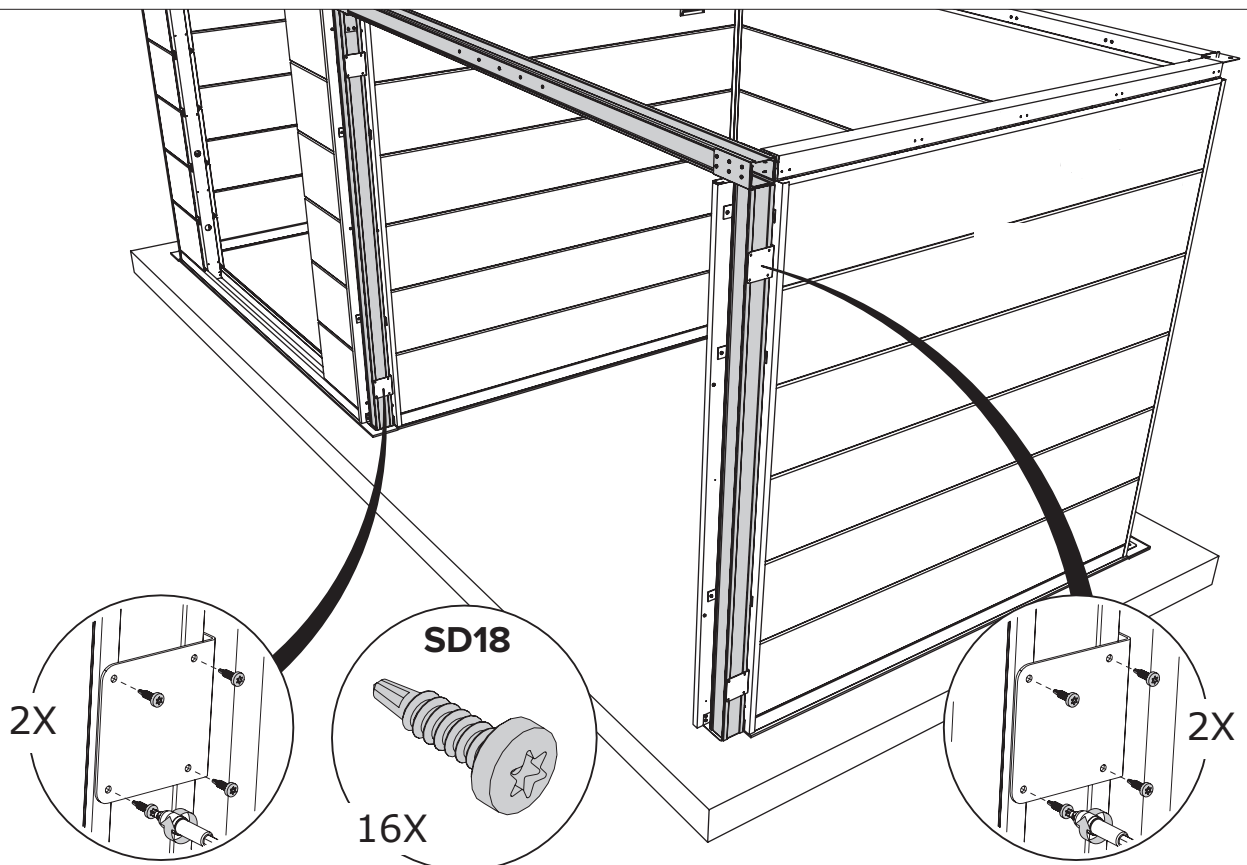

F Paroi / Wand / Wall / Wand

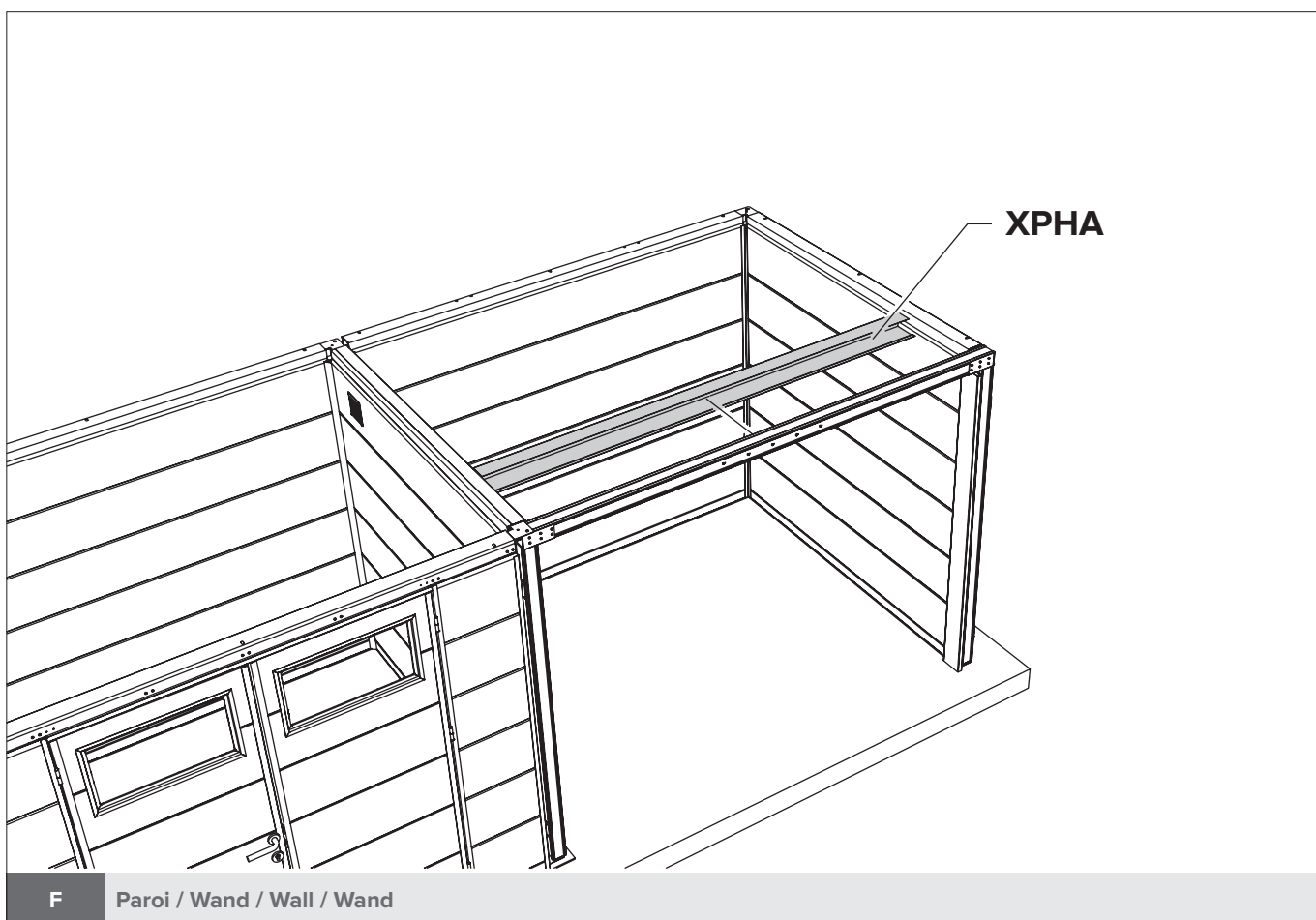
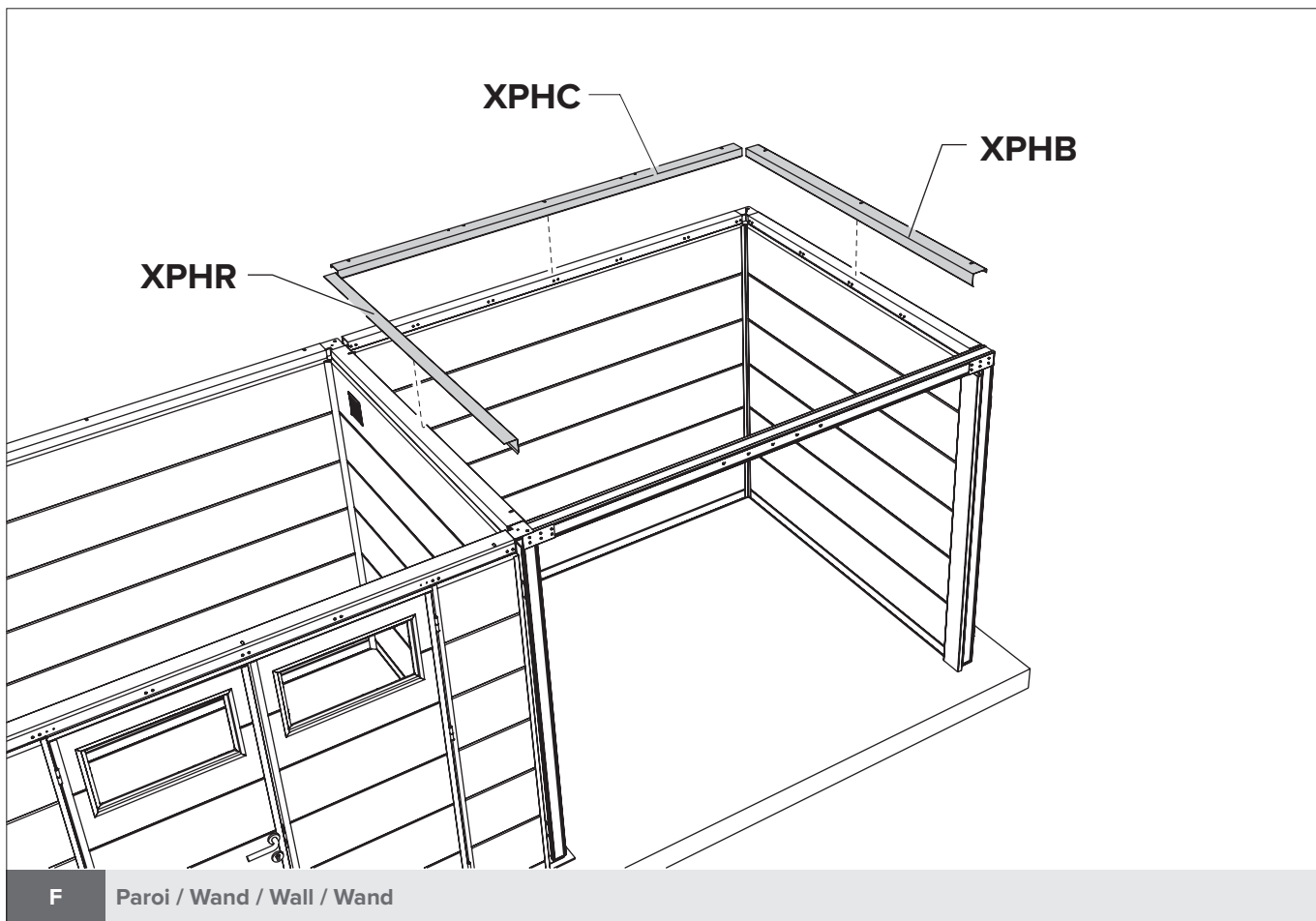

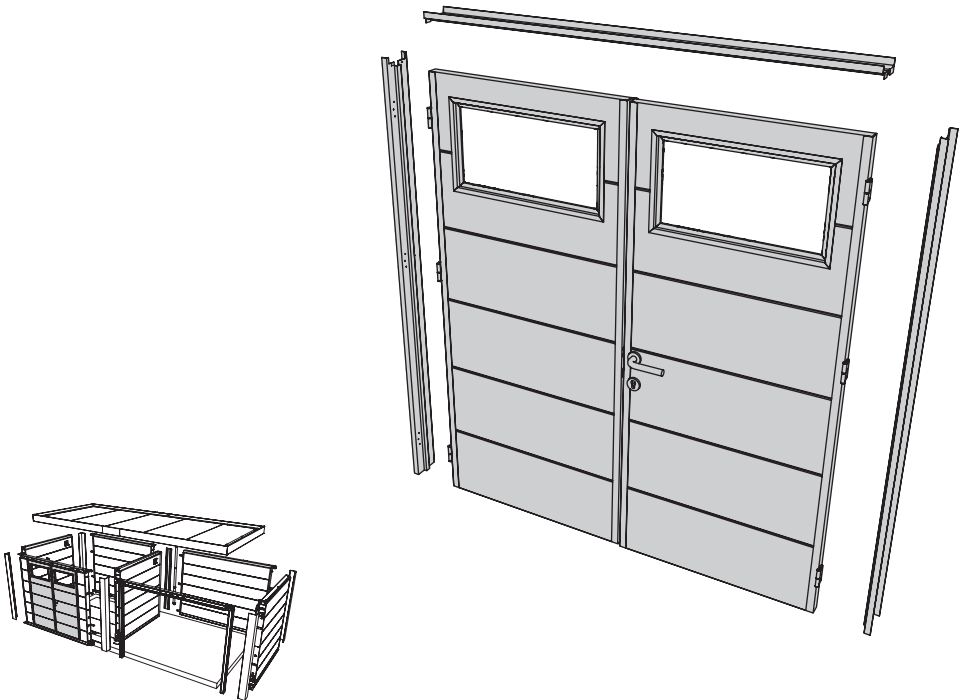

Porte / Deur / Door / Tür

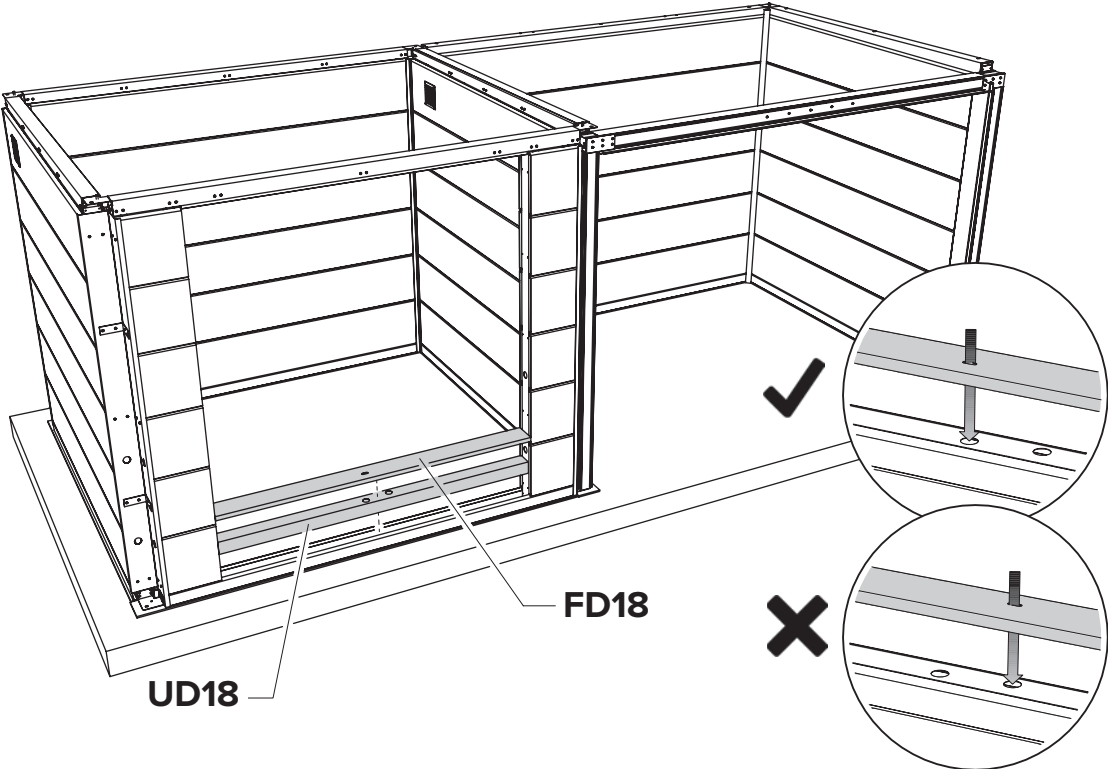

Porte / Deur / Door / Tür

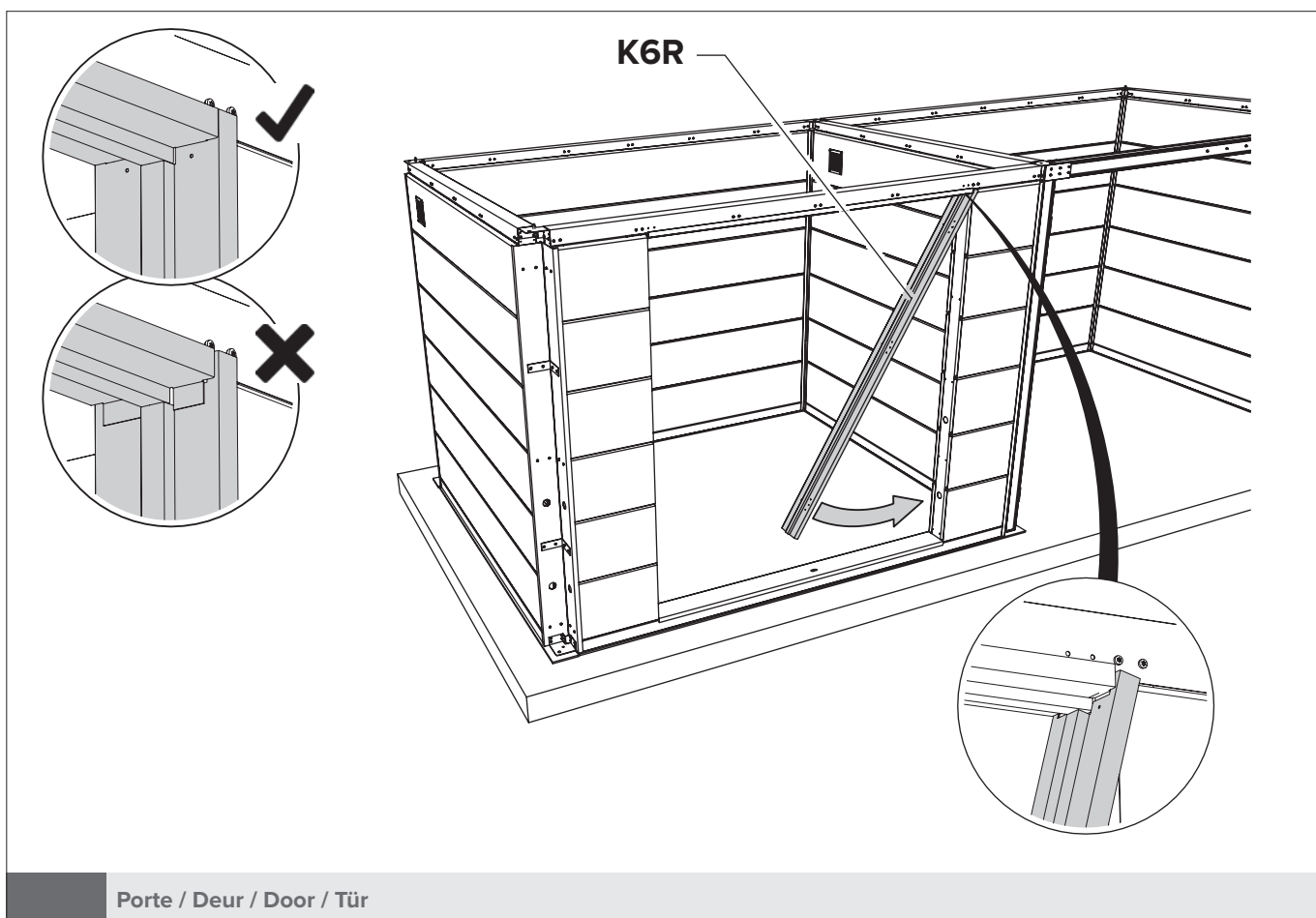
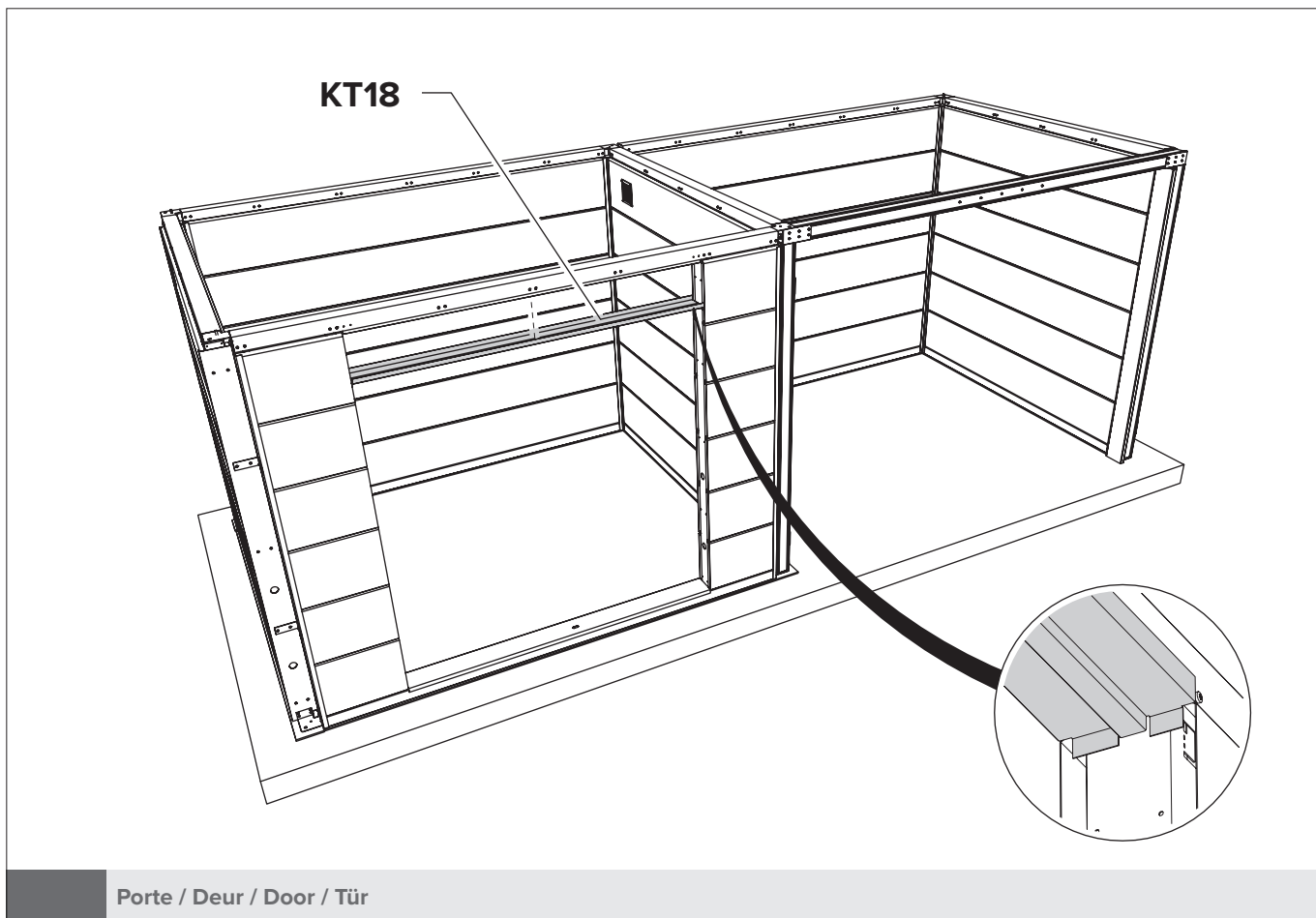

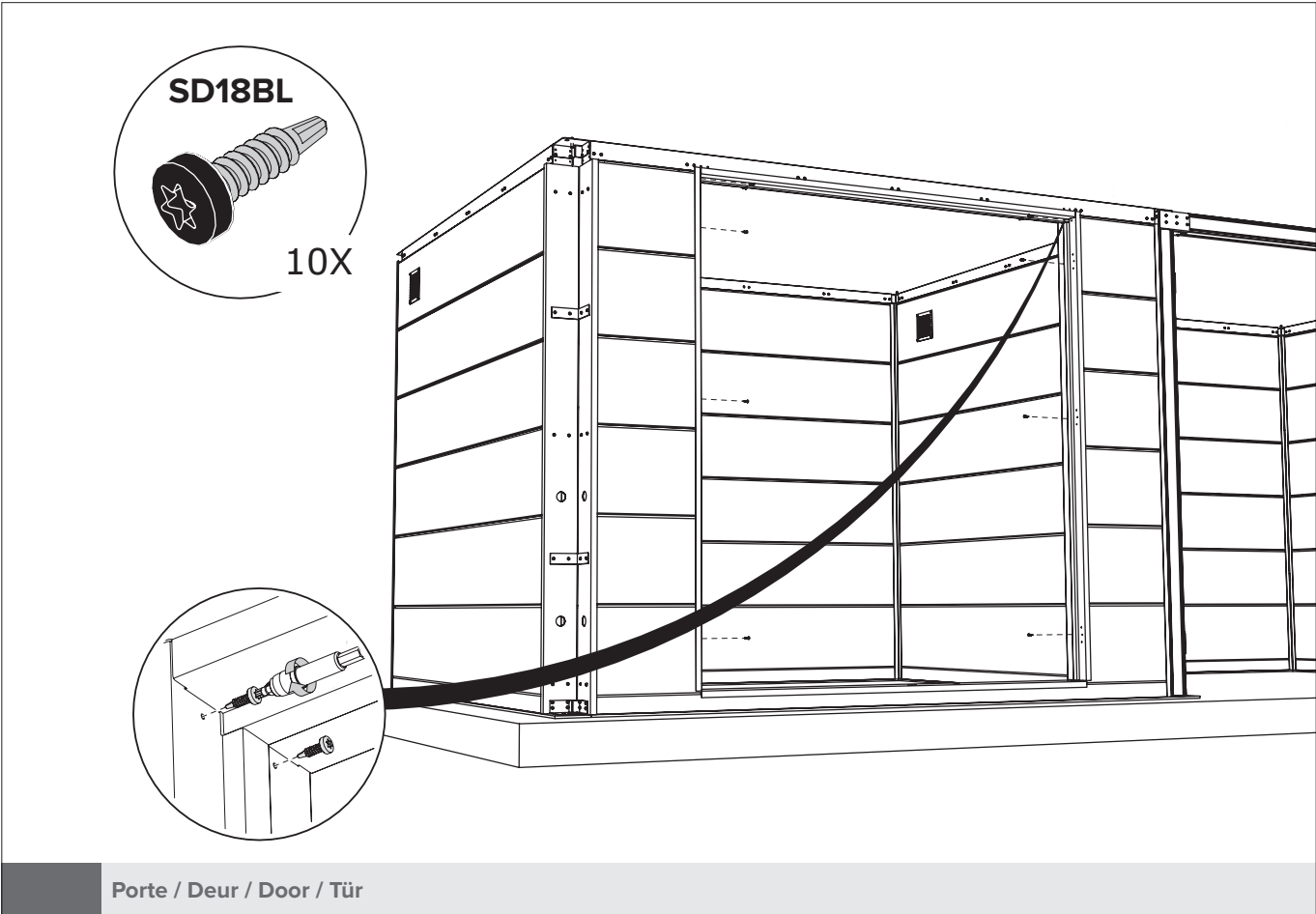
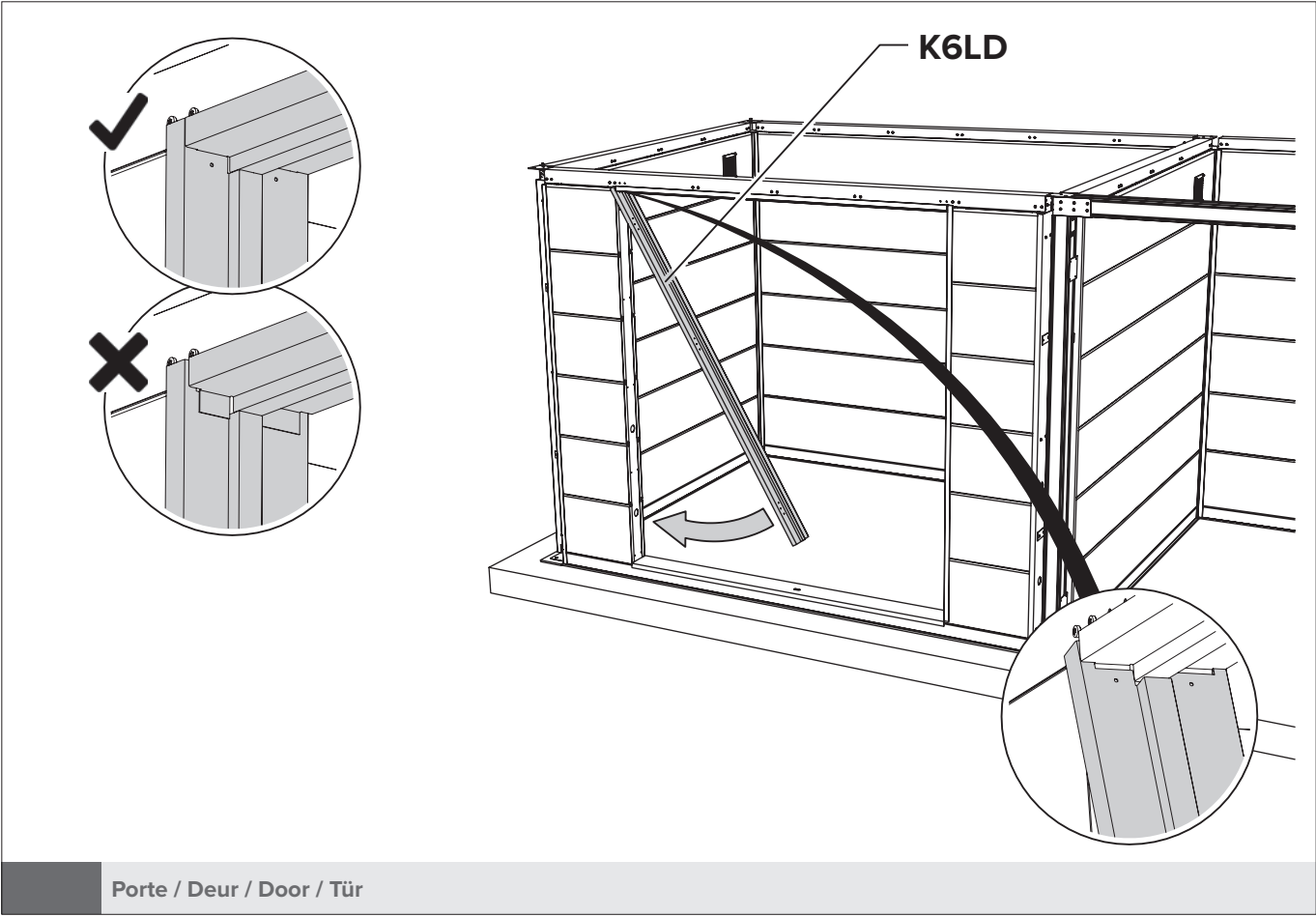

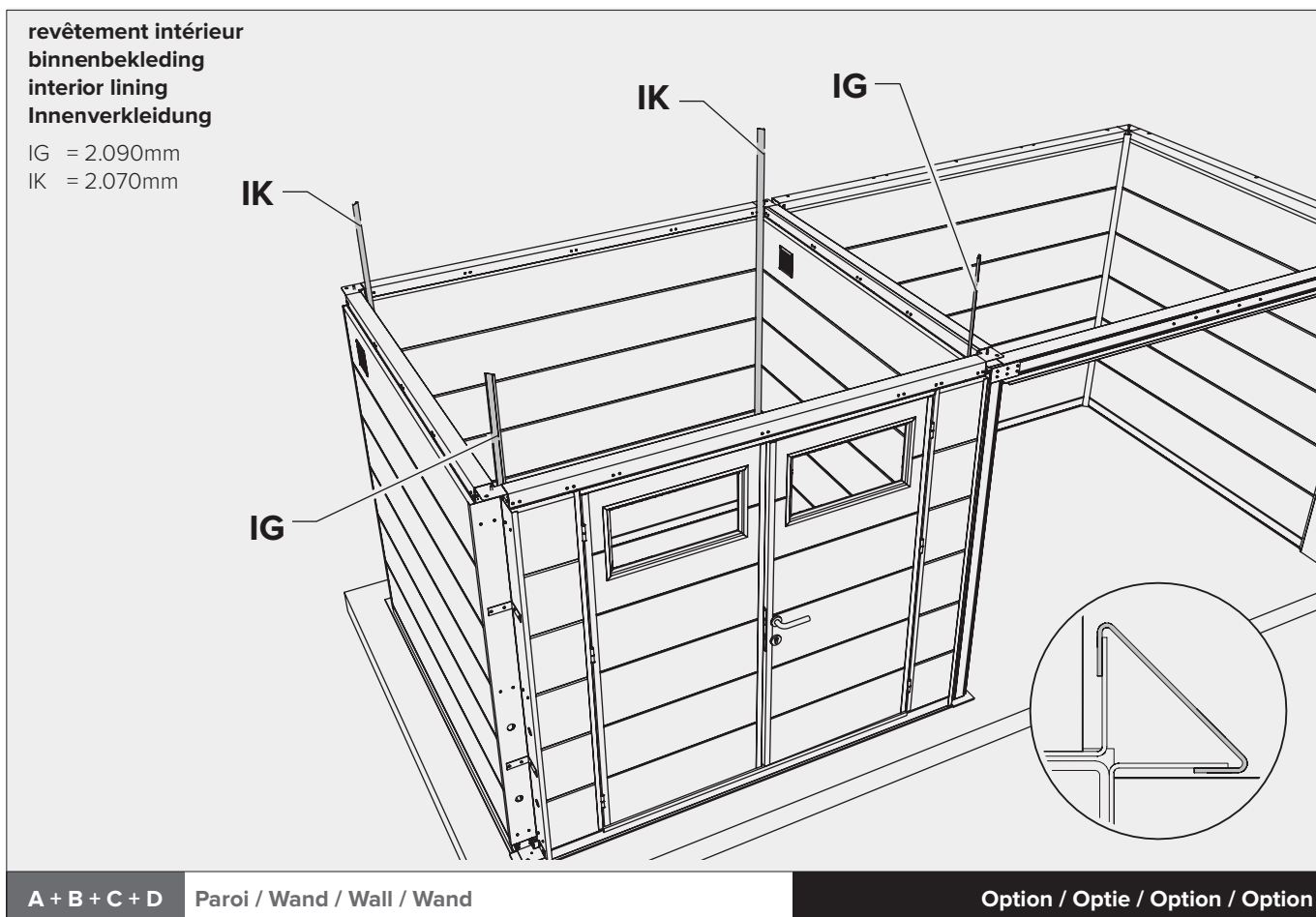
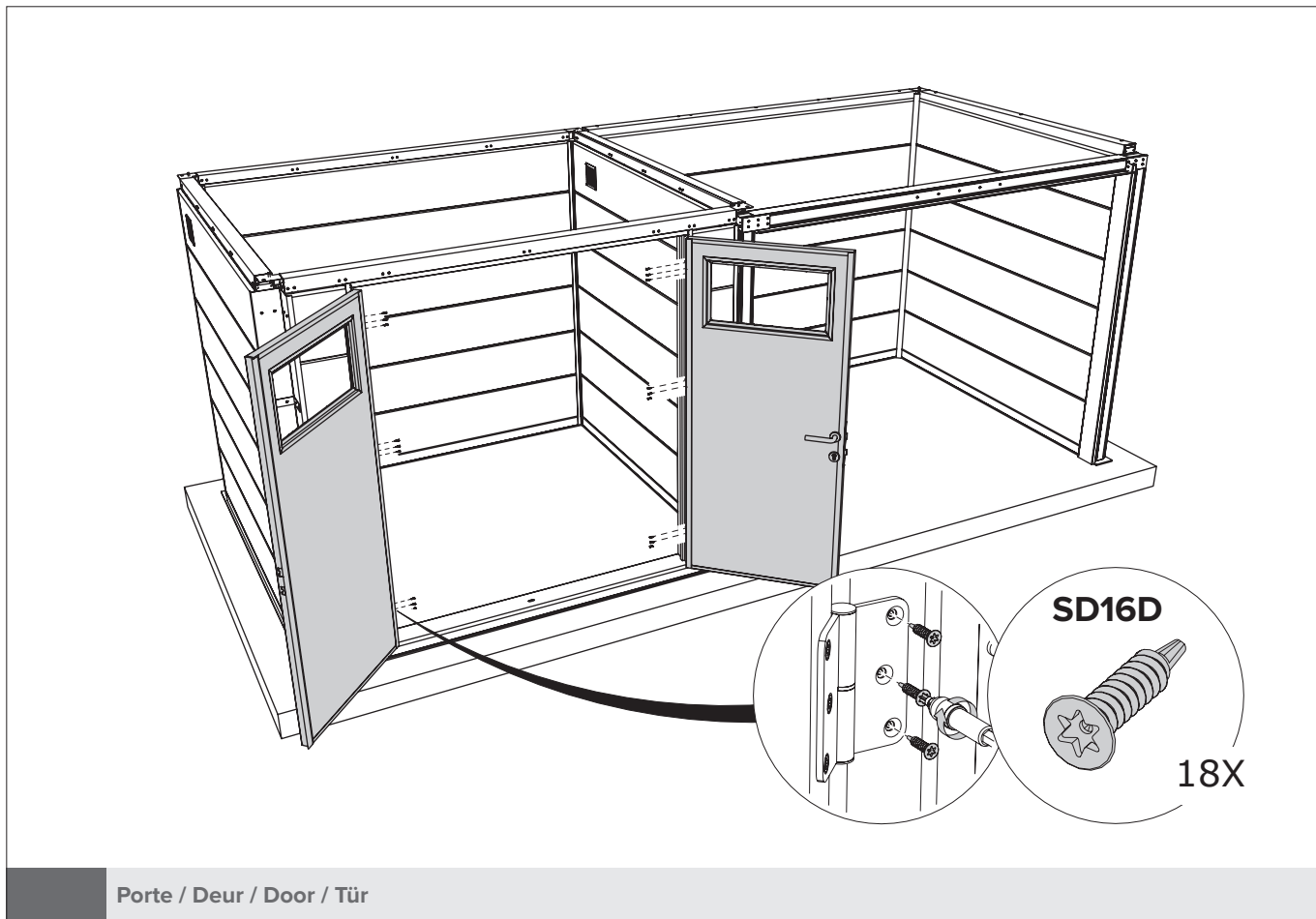

revêtement intérieur
binnenbekleding
interior lining
Innenverkleidung

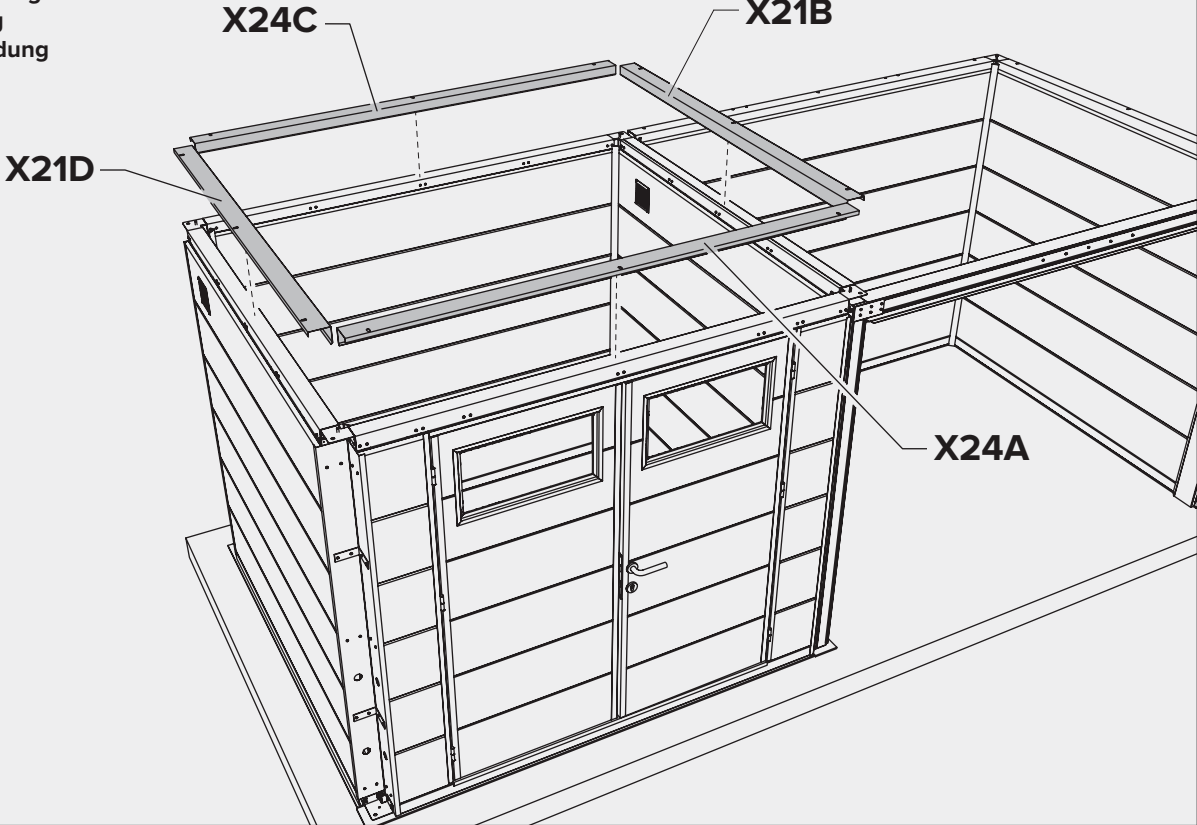

A + B + C + D Paroi / Wand / Wall / Wand

Option / Optie / Option / Option

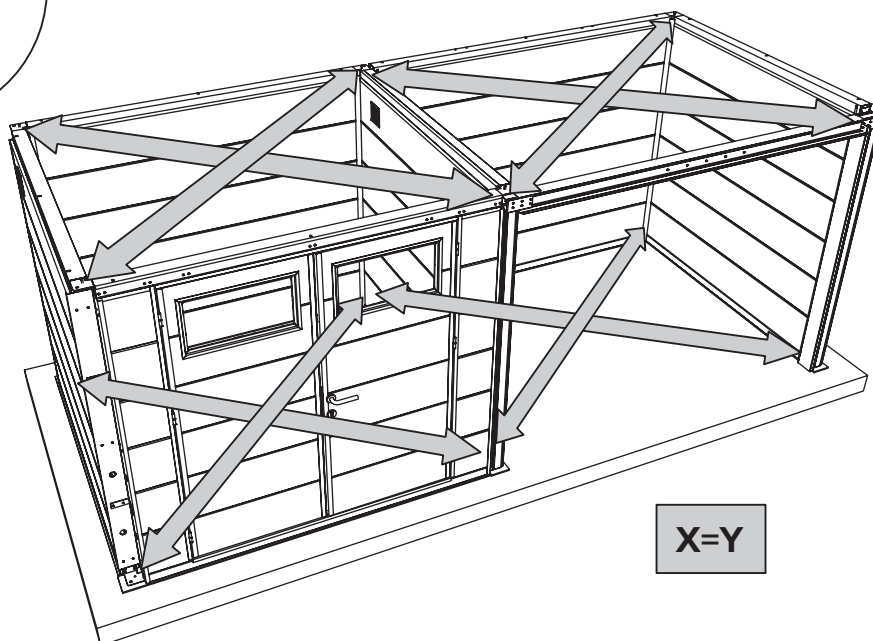
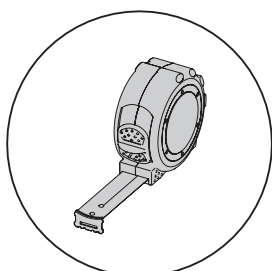
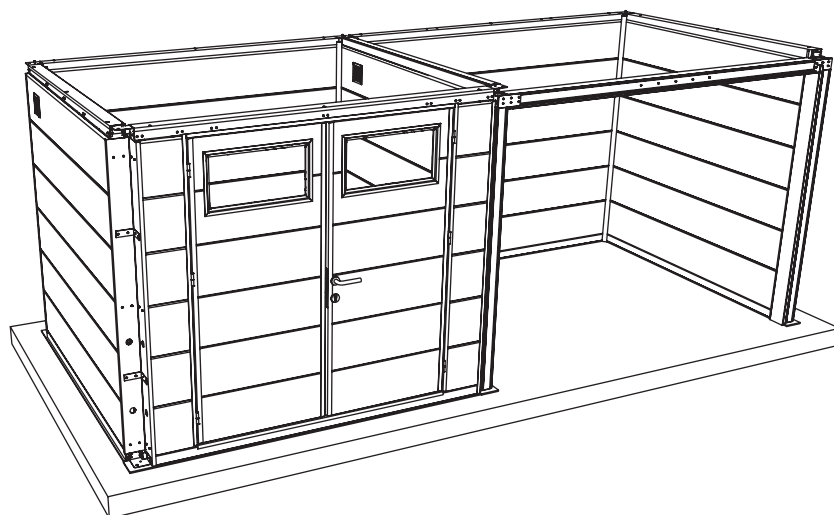
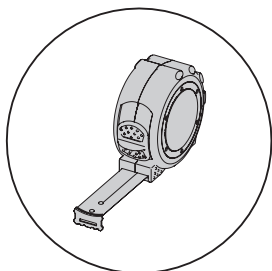

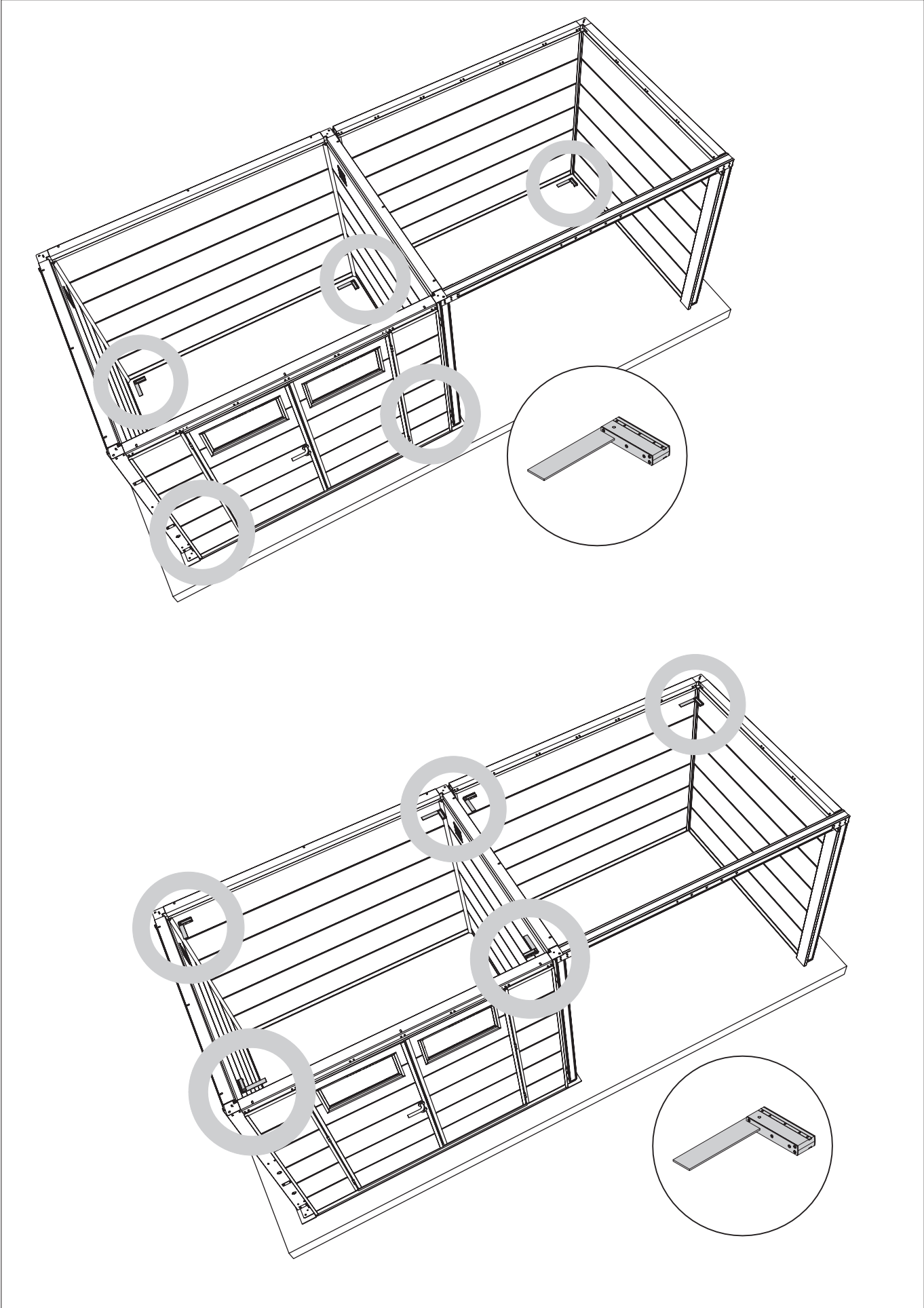

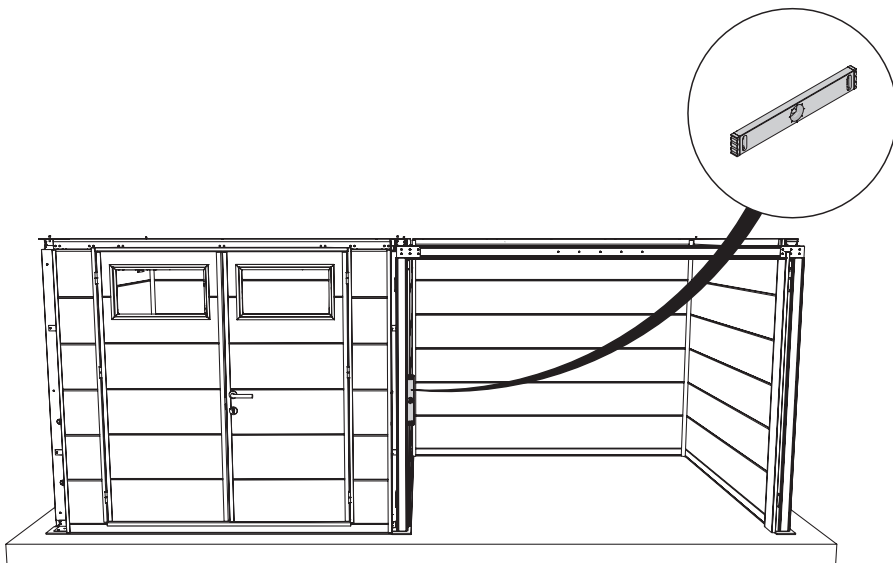
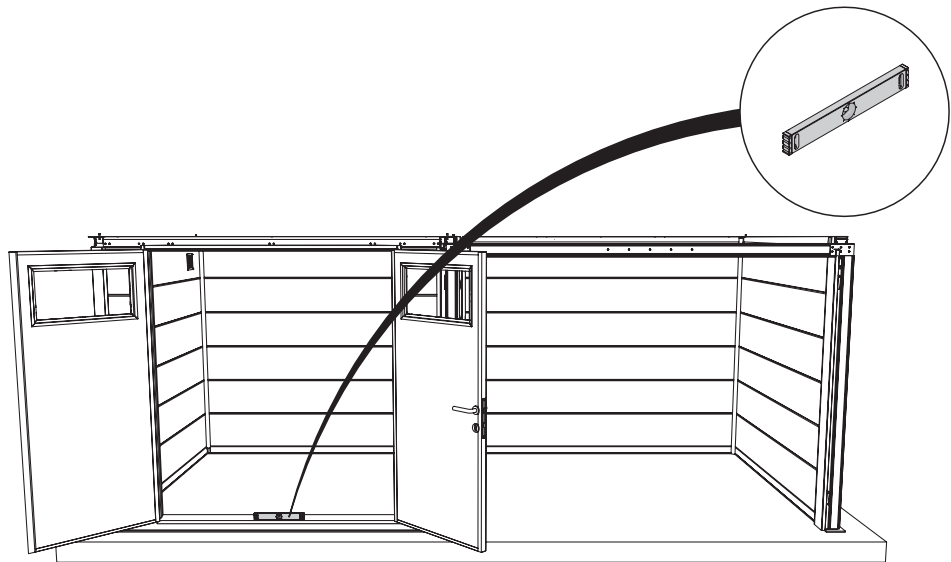
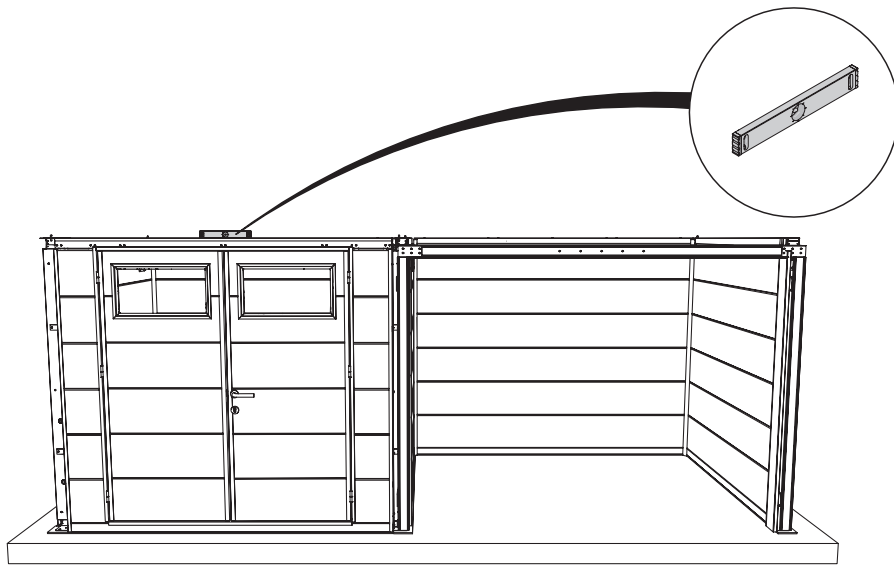

Retirer le film / Verwijder folie / Remove foil / Folie entfernen

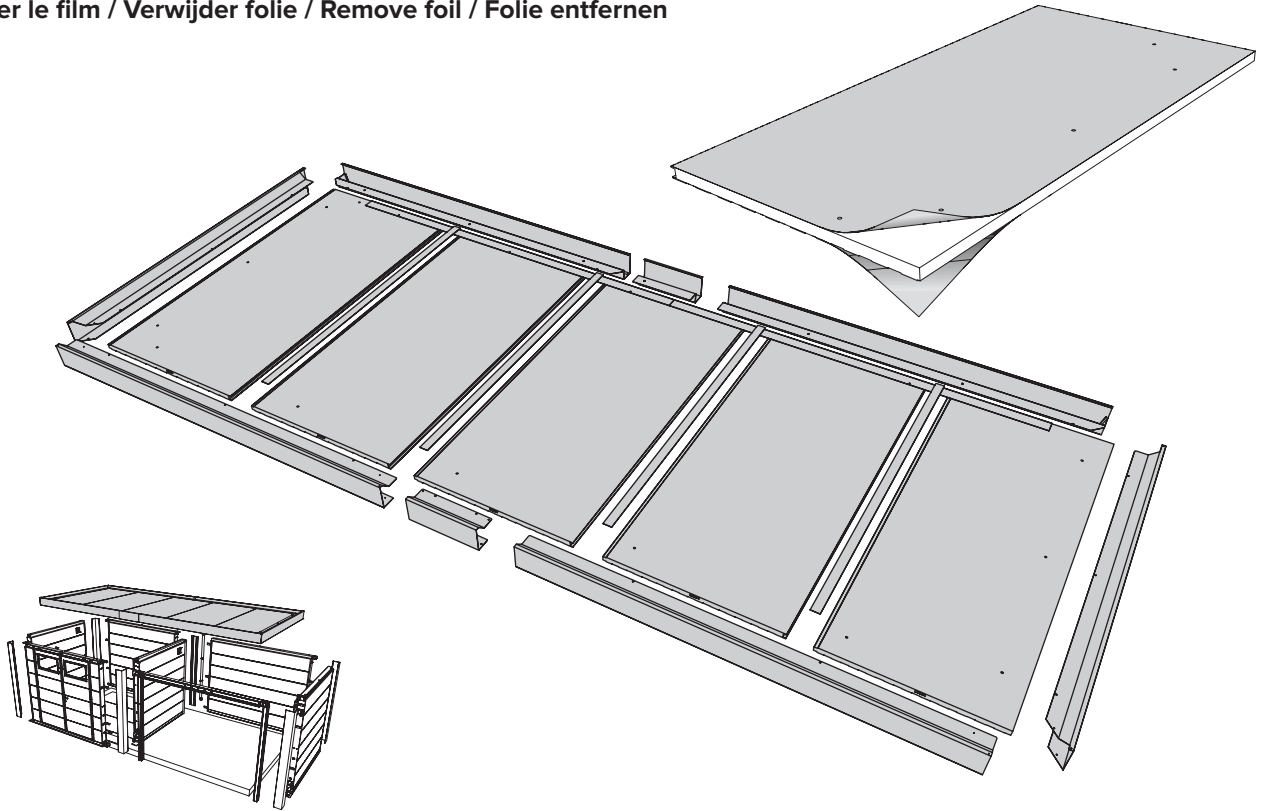

Toit / Dak / Roof / Dach

Retirer la bande / Tape verwijderen / Remove tape / Klebeband entfernen

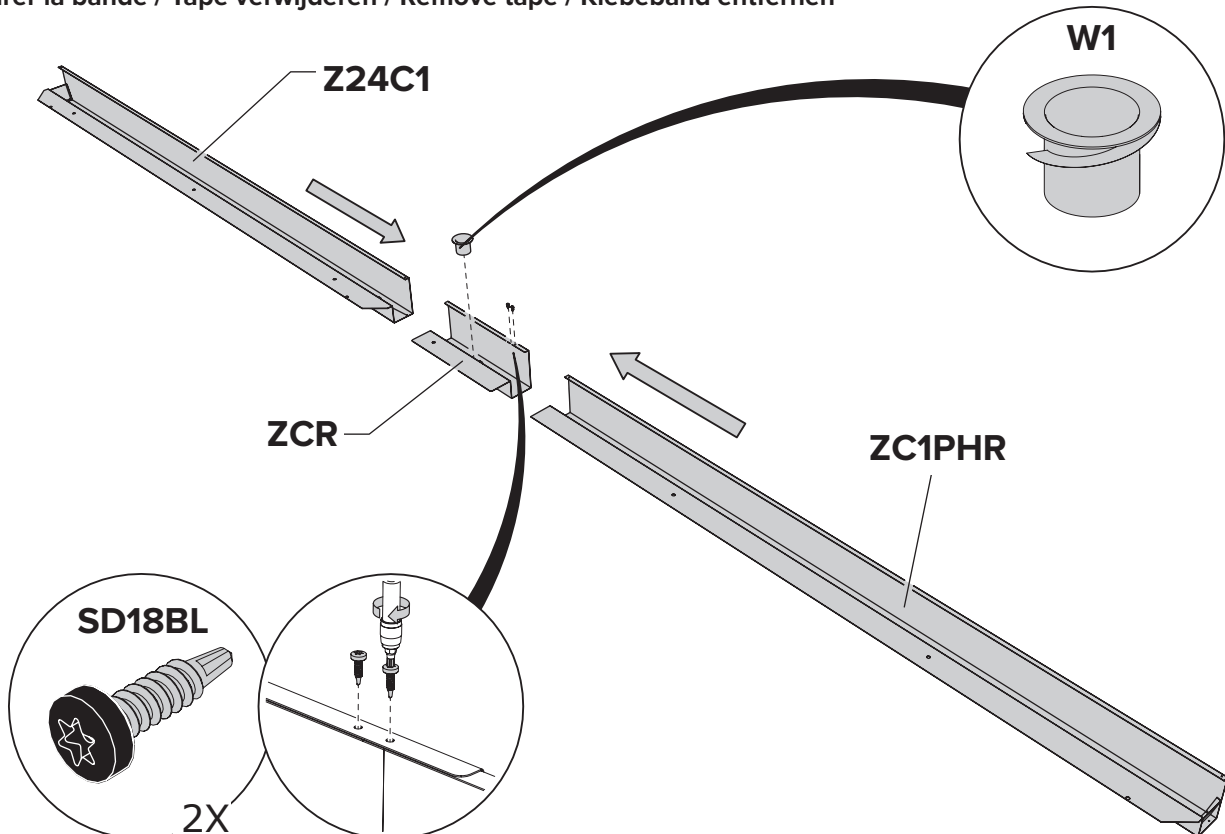

Toit / Dak / Roof / Dach

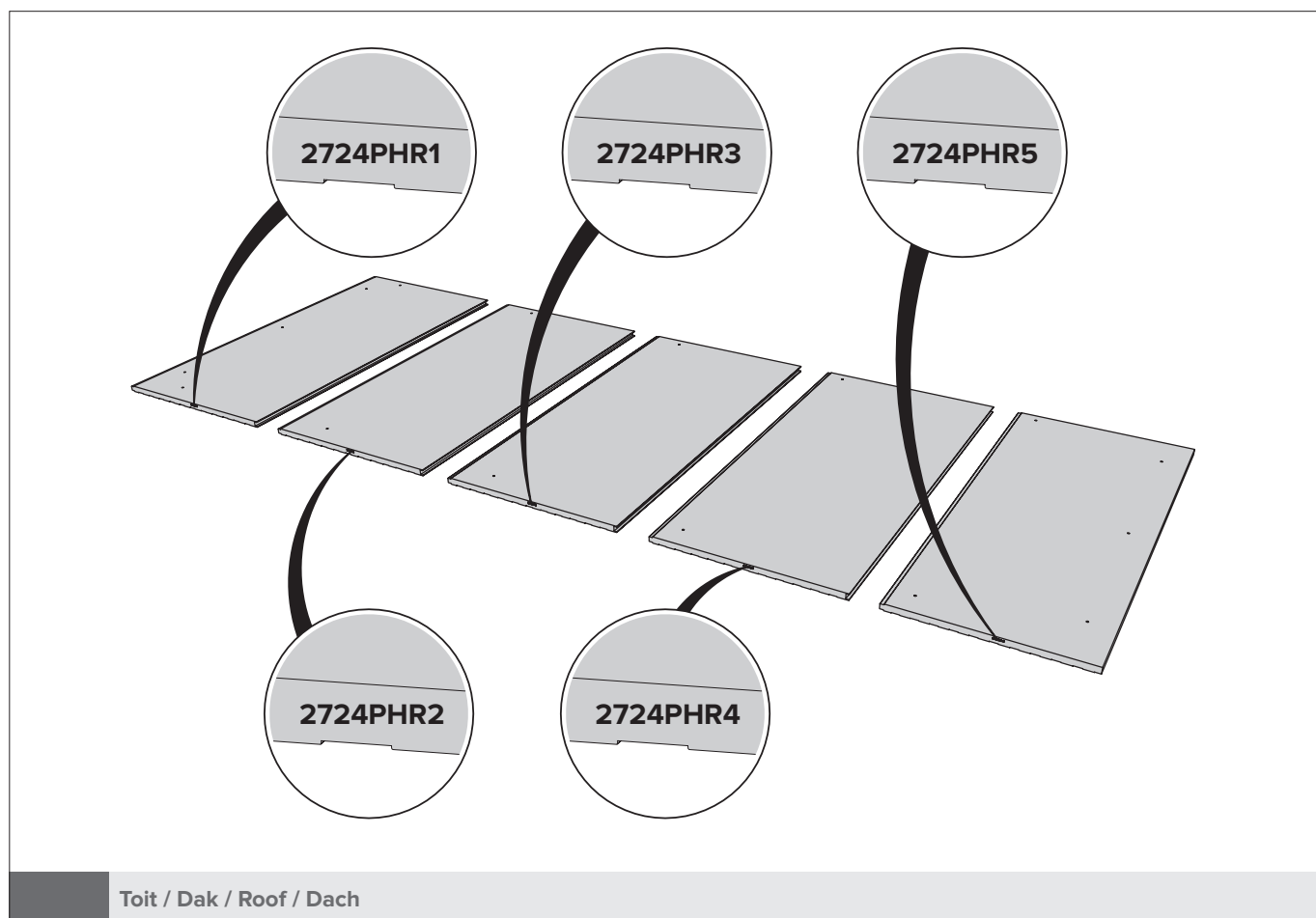
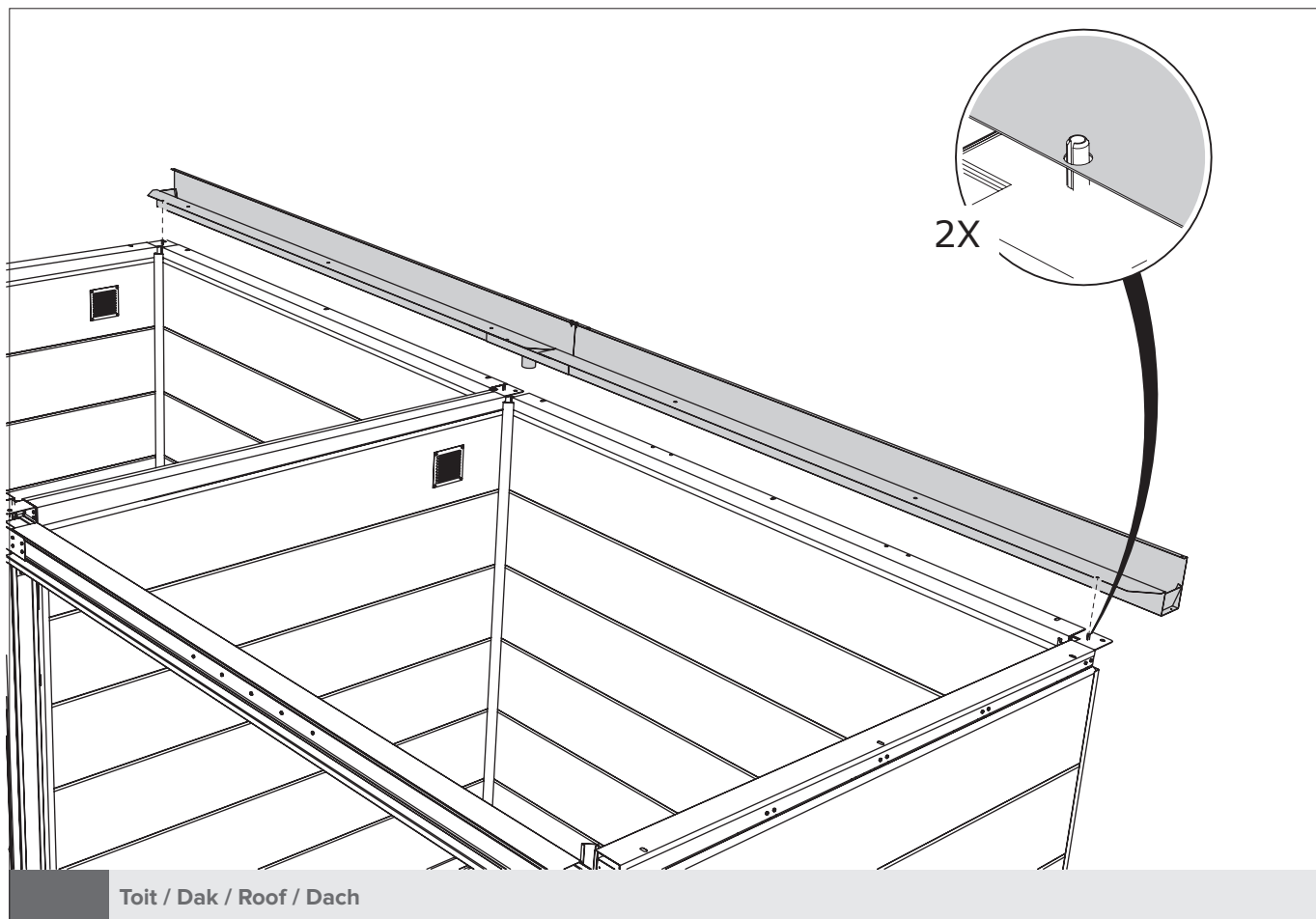

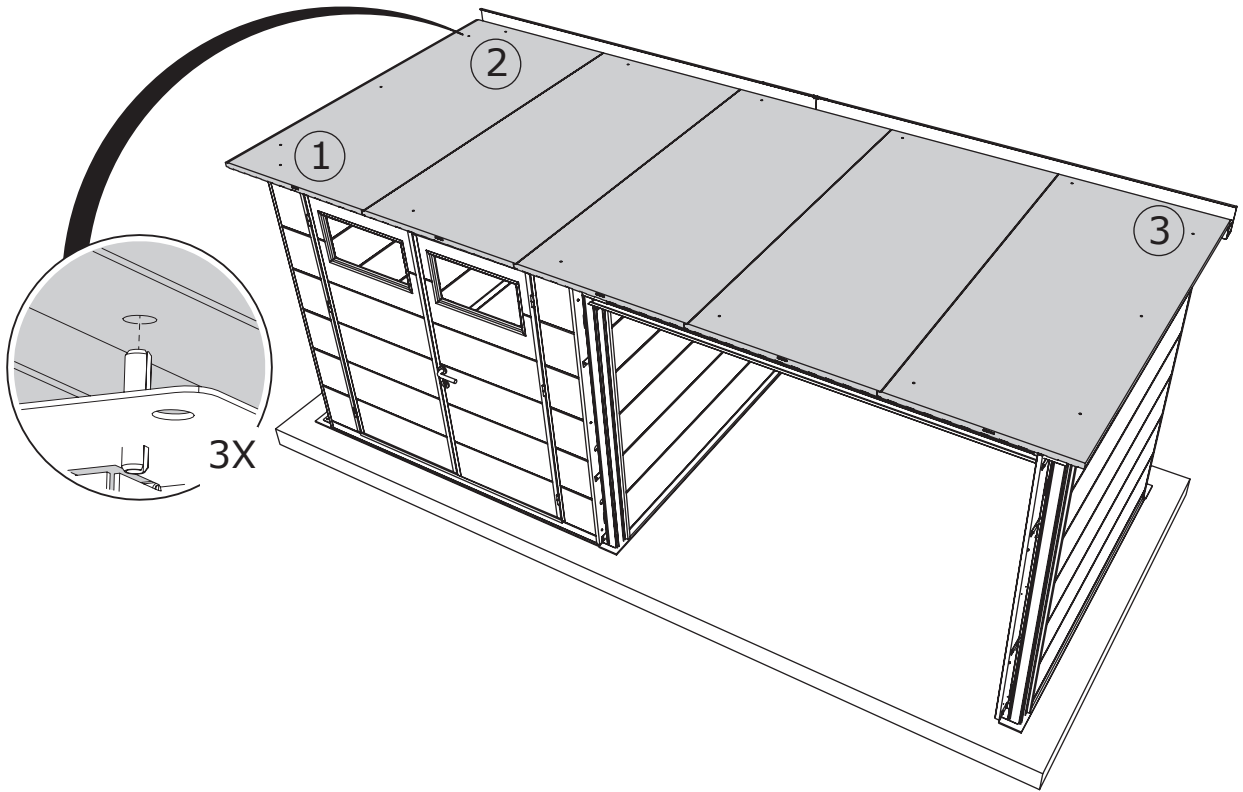

Toit / Dak / Roof / Dach

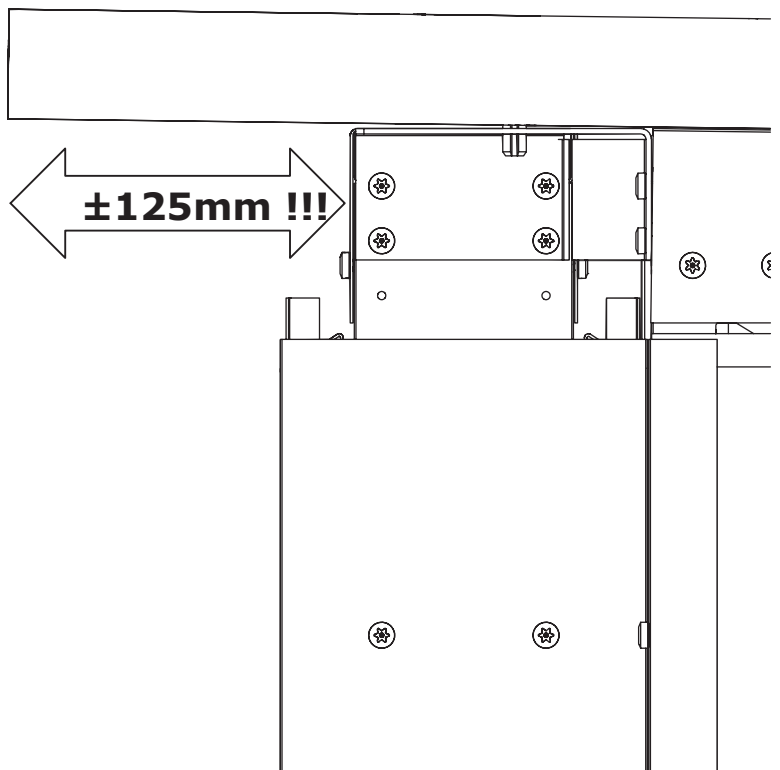
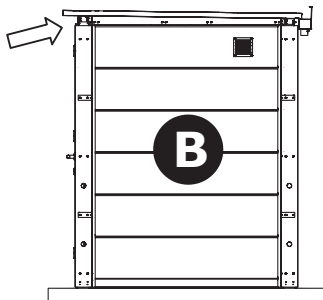
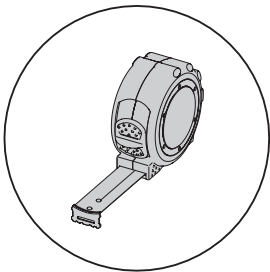

Toit / Dak / Roof / Dach

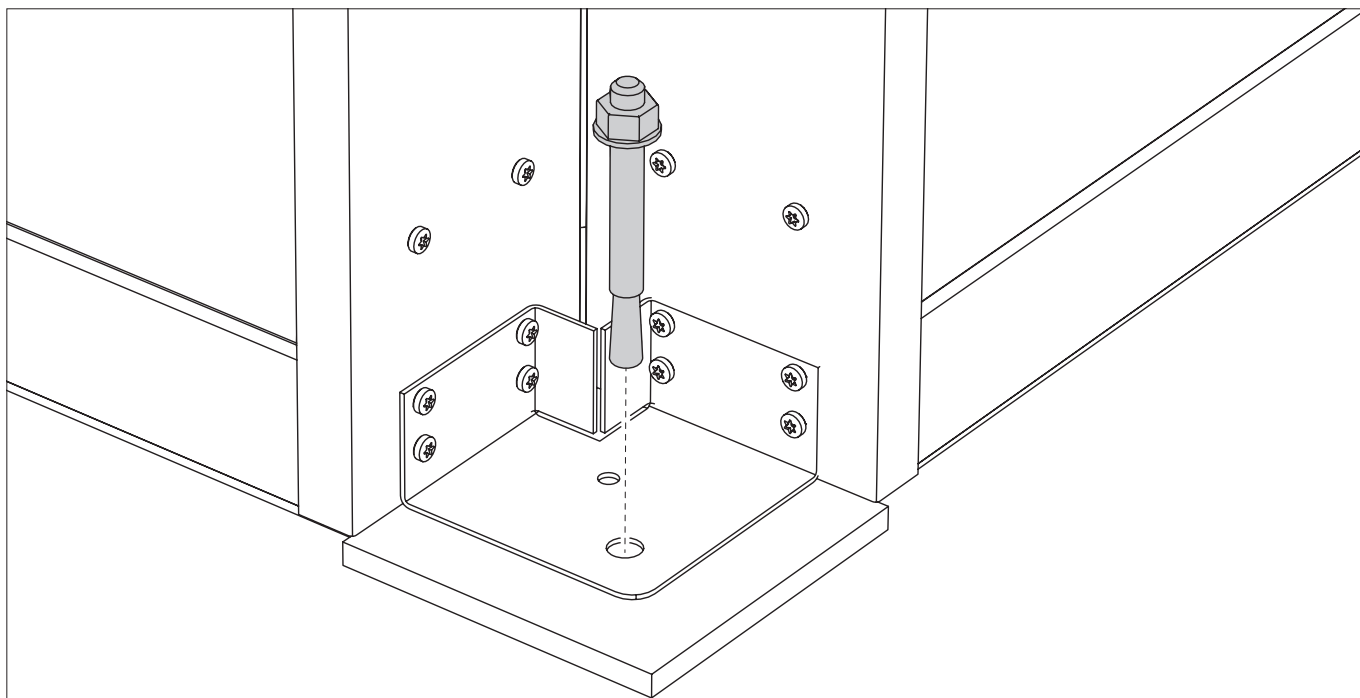

Exemple donné pour un sous-sol en béton. Fixer l'abri de jardin dans les règles de l'art.
 Voorbeeld is voor beton-ondergrond. Tuinhuisje fixeren volgens de regels van de kunst.
 Example is for concrete substrate. Fix the garden shed in accordance with good practise.
 Beispiel ist für Betonuntergrund. Fachgerechte Befestigung des Gartenhäuschens.

Ancrage / Verankering / Anchoring / Verankerung

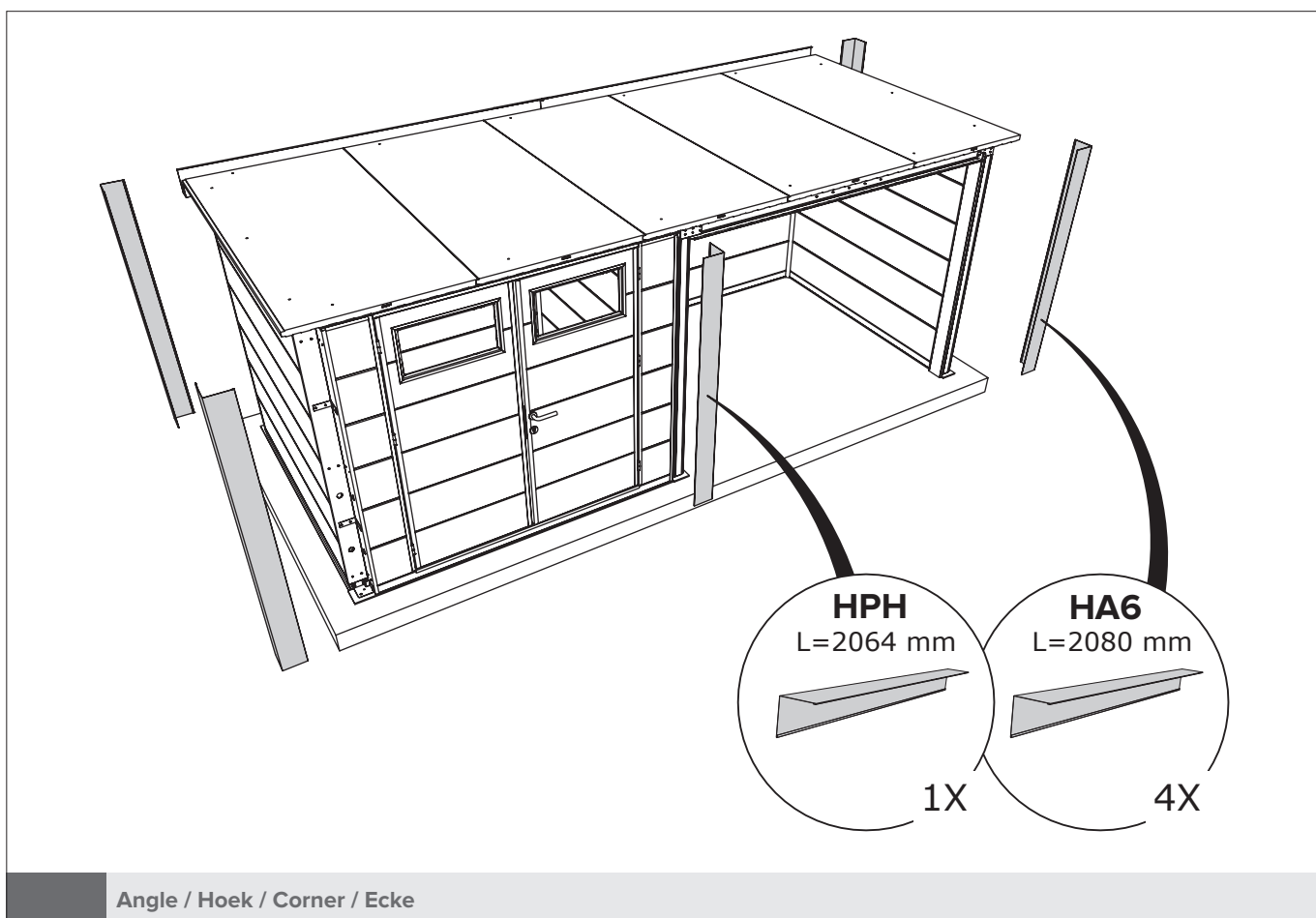

Angle / Hoek / Corner / Ecke

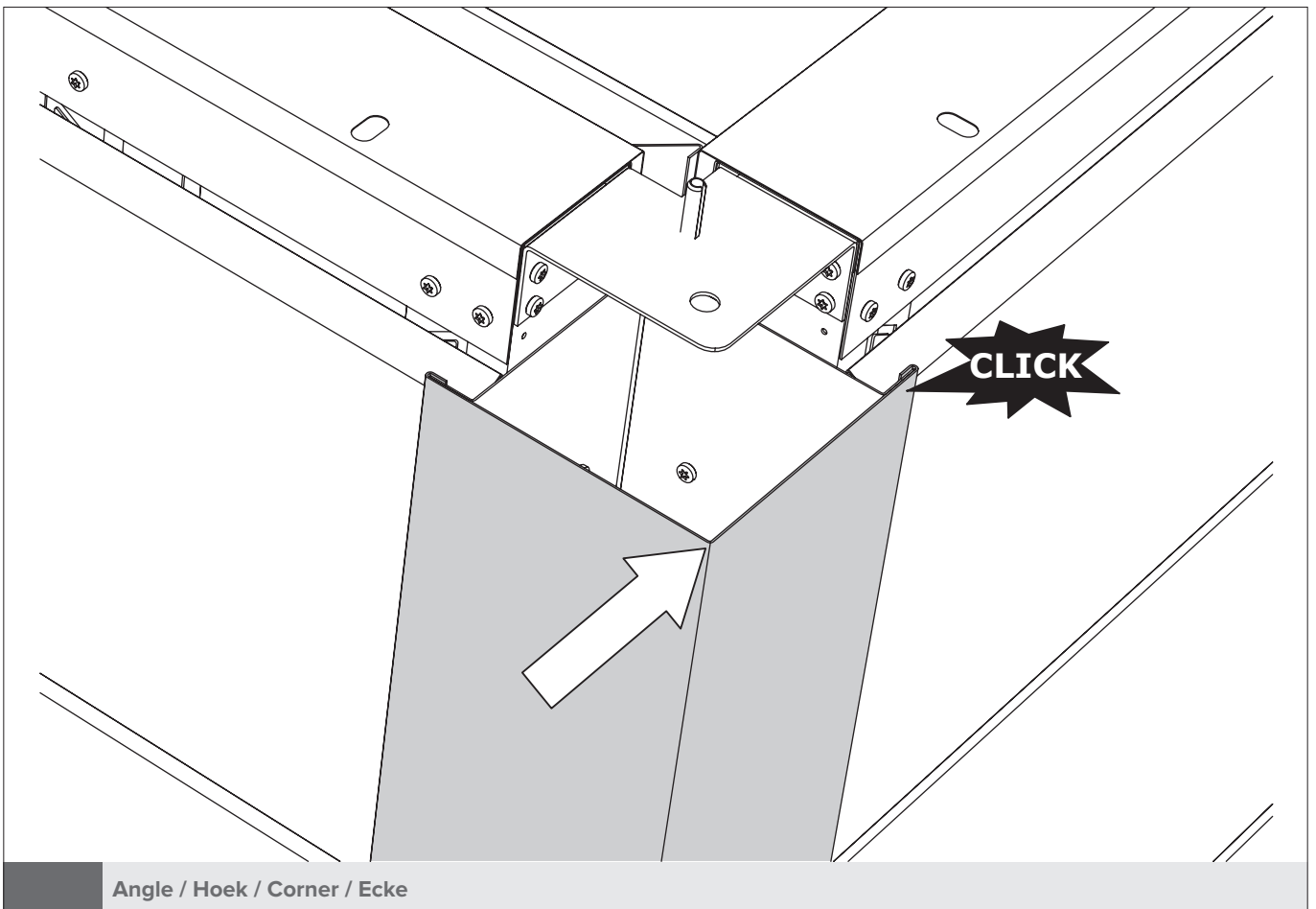
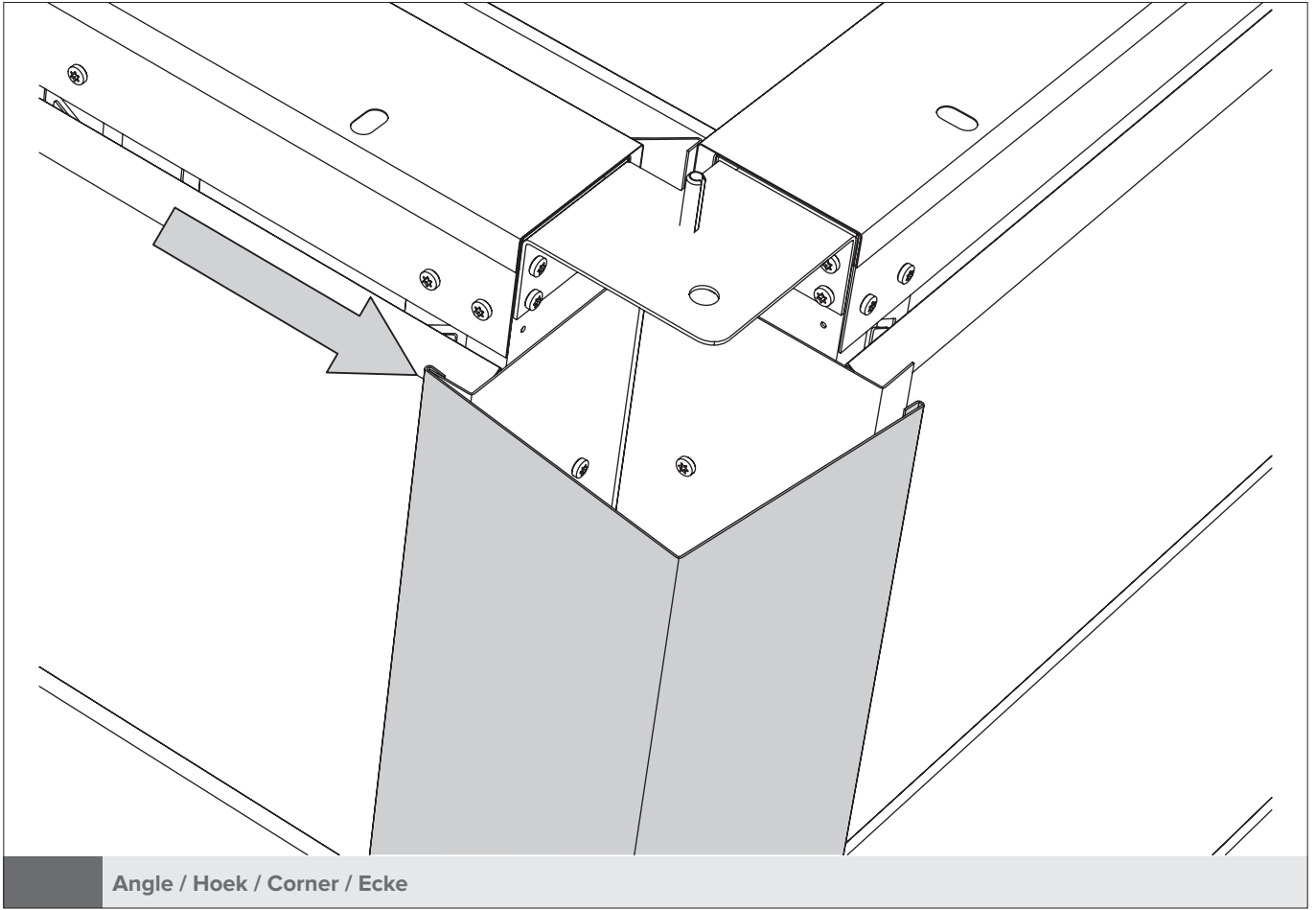

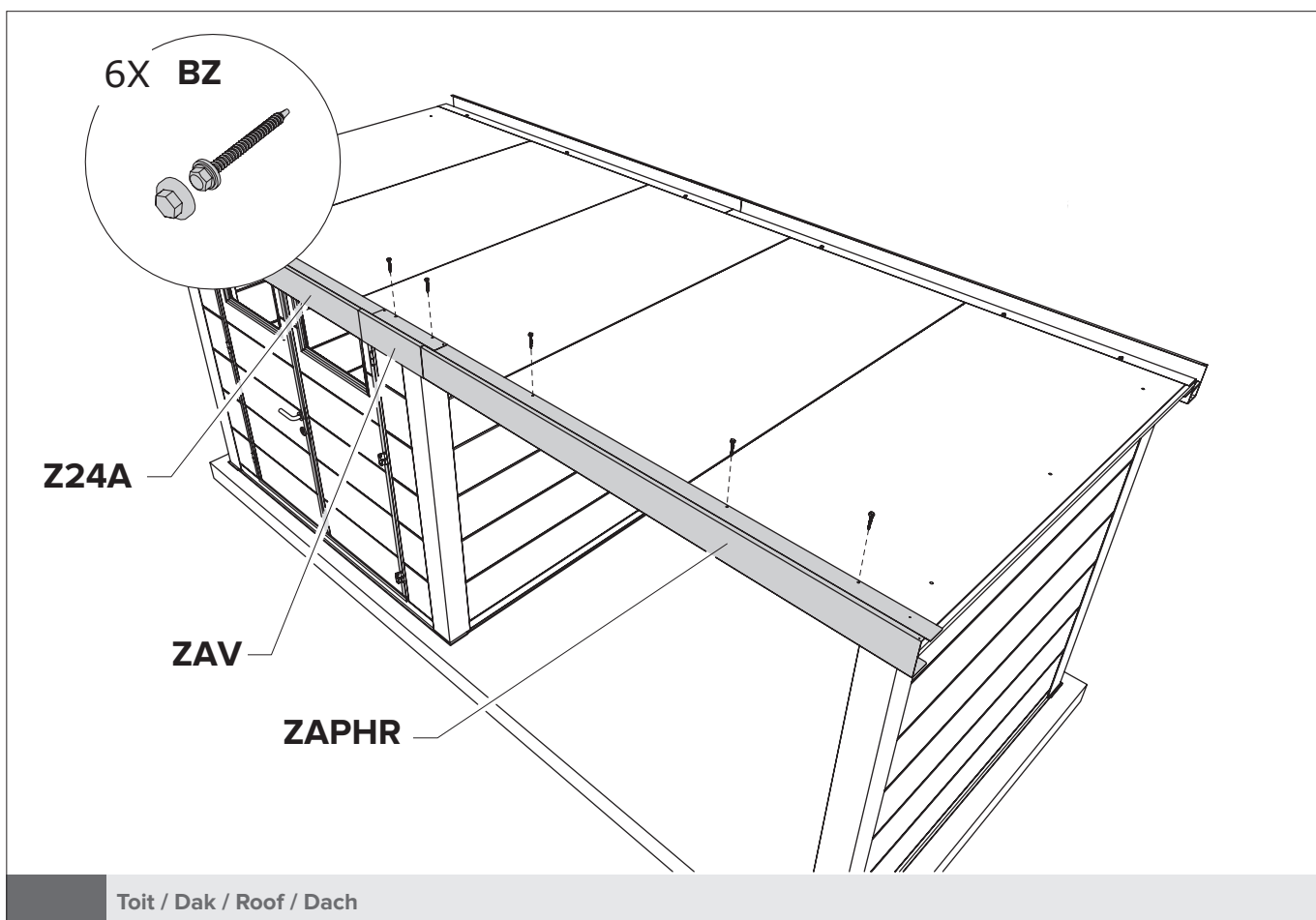
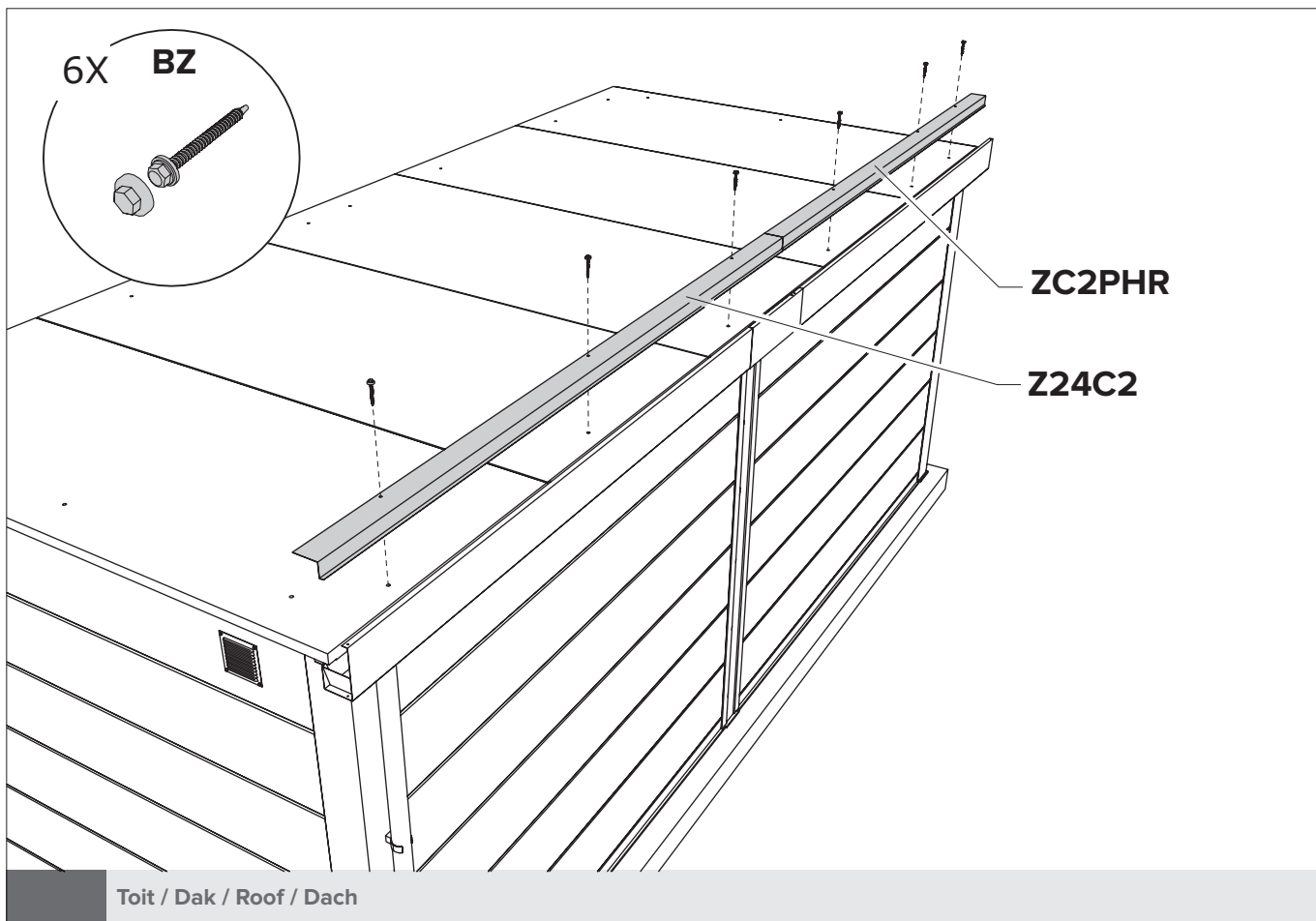

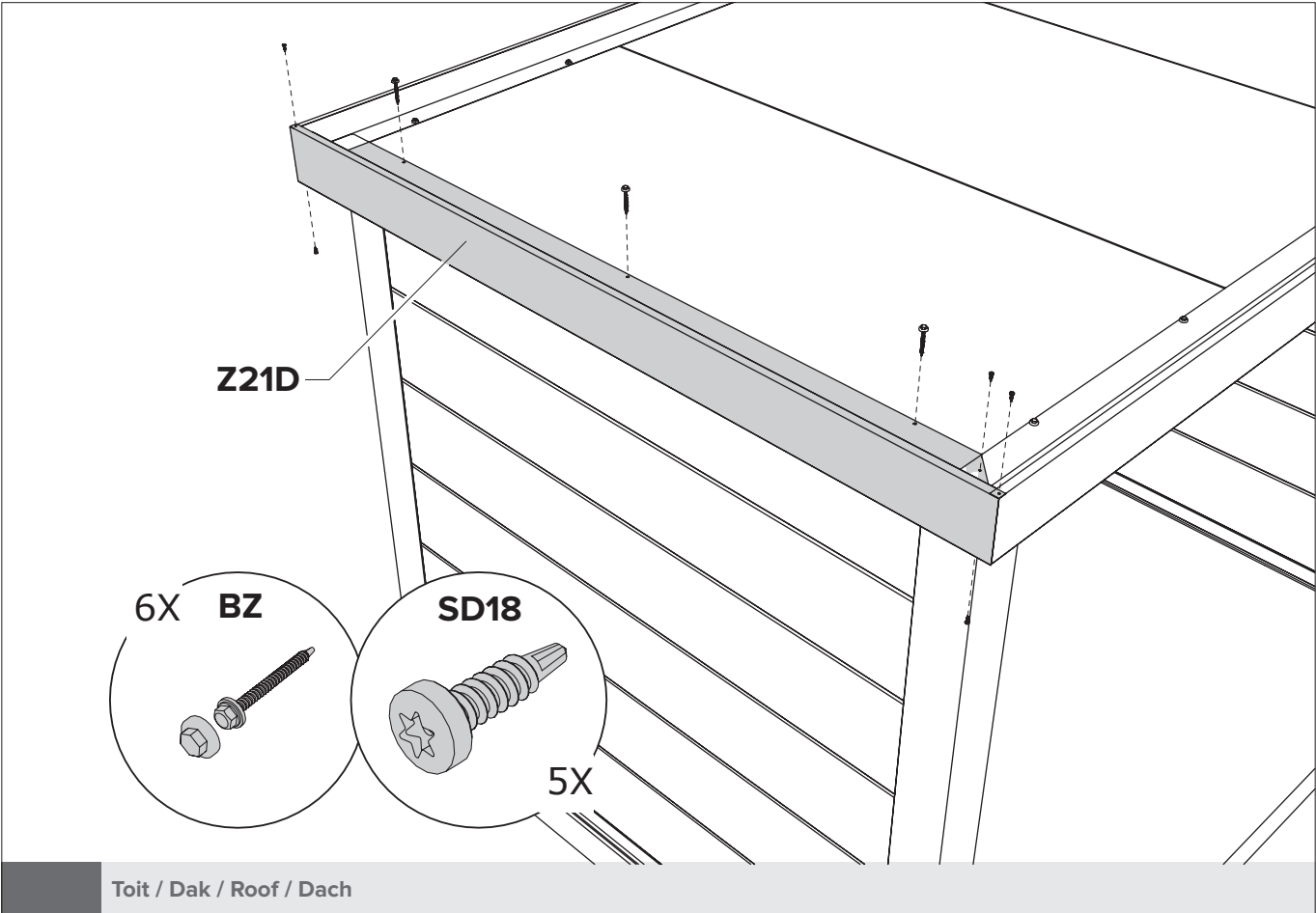
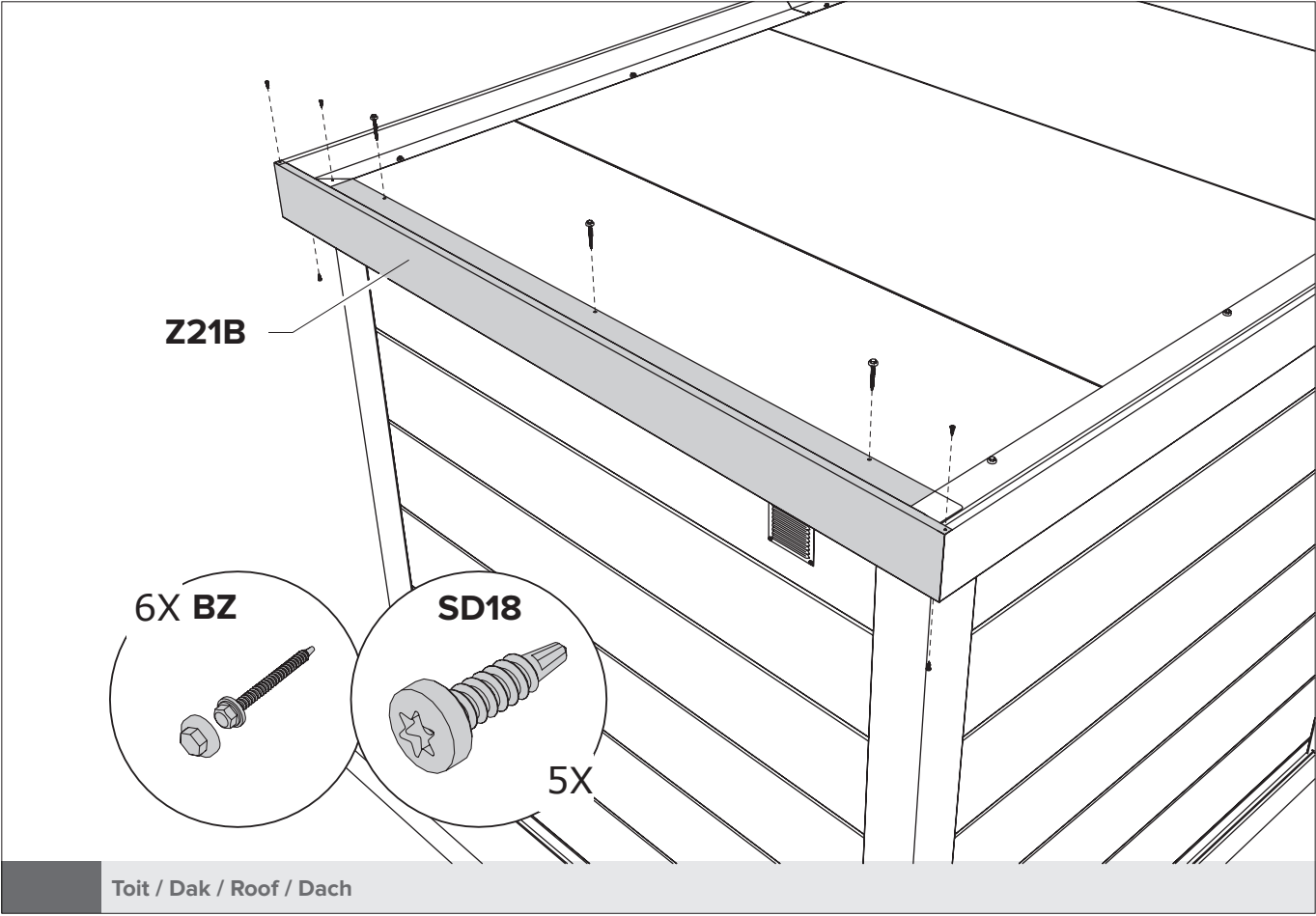

Préparation du ruban auto-adhésif:

1. Bien nettoyer la surface afin qu'il n'y ai ni poussière, ni humidité.
2. Chauffer la surface dans le cas d'une température extérieure <10 ° C.

Vorbereiding zelfklevende tape:

1. Oppervlak stof- en vochtvrij maken”.
2. Bij <10°C is opwarmen ondergrond d.m.v. warmtepistool (Föhn) vereist”.

Preparation of self-adhesive tape:

1. Make the surface dust-free and moisture-free.
2. Heat up the surface in case of <10 ° C outside temperature.

Vorbereitung des Klebebandes:

1. Machen Sie die Oberfläche staubfrei und feuchtigkeitsfrei.
2. Erwärmen Sie die Oberfläche bei einer Außentemperatur von <10 ° C.

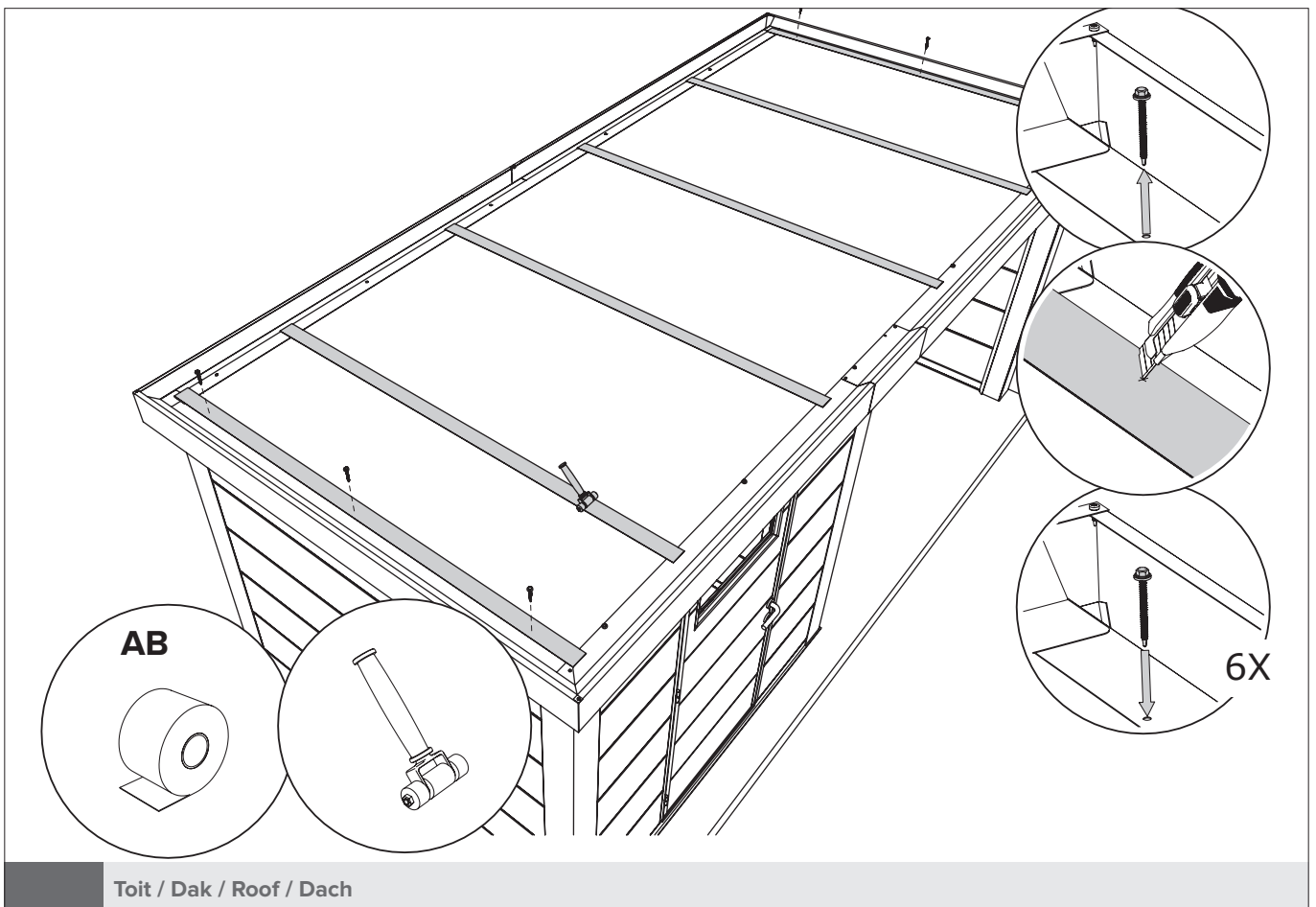
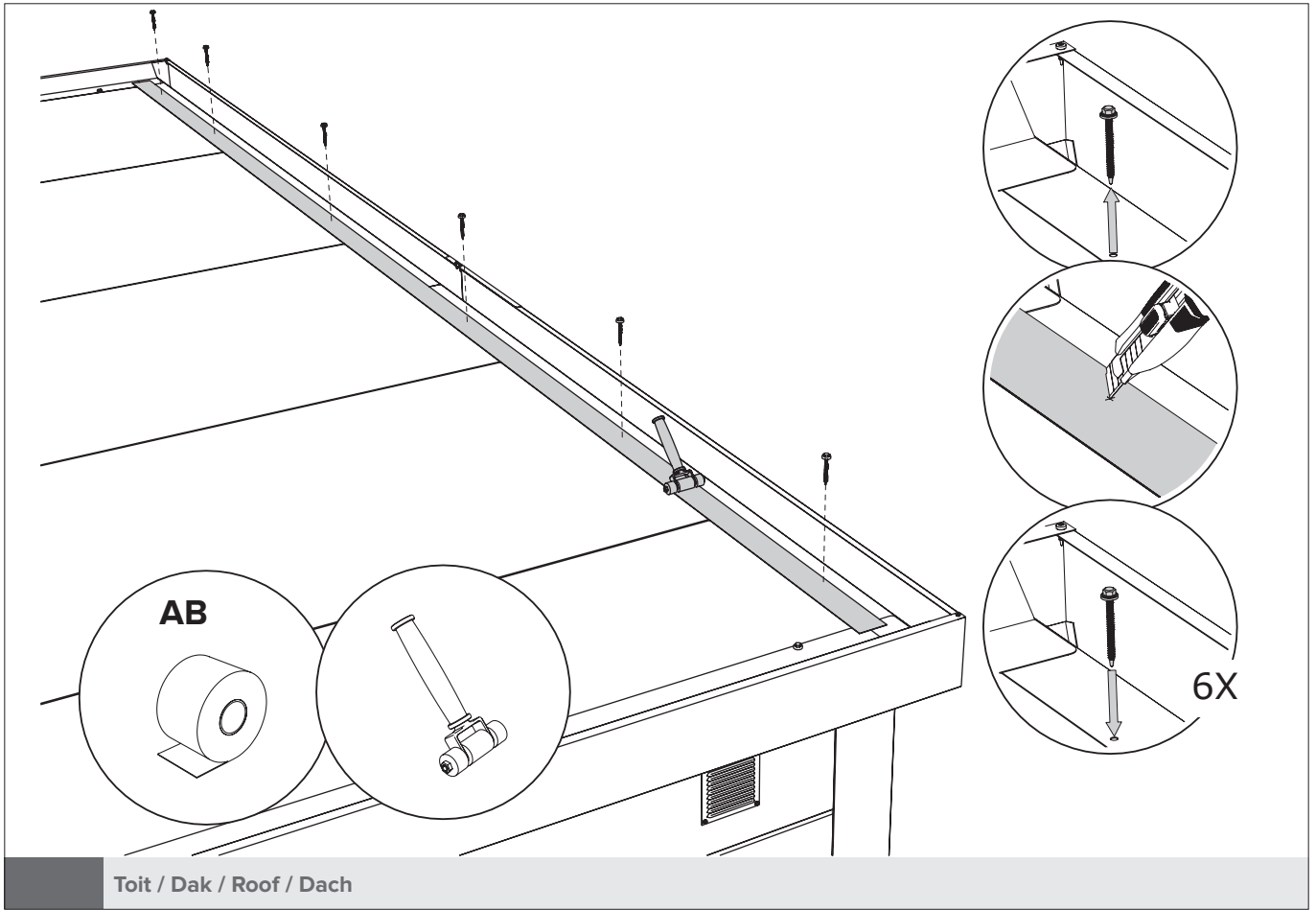

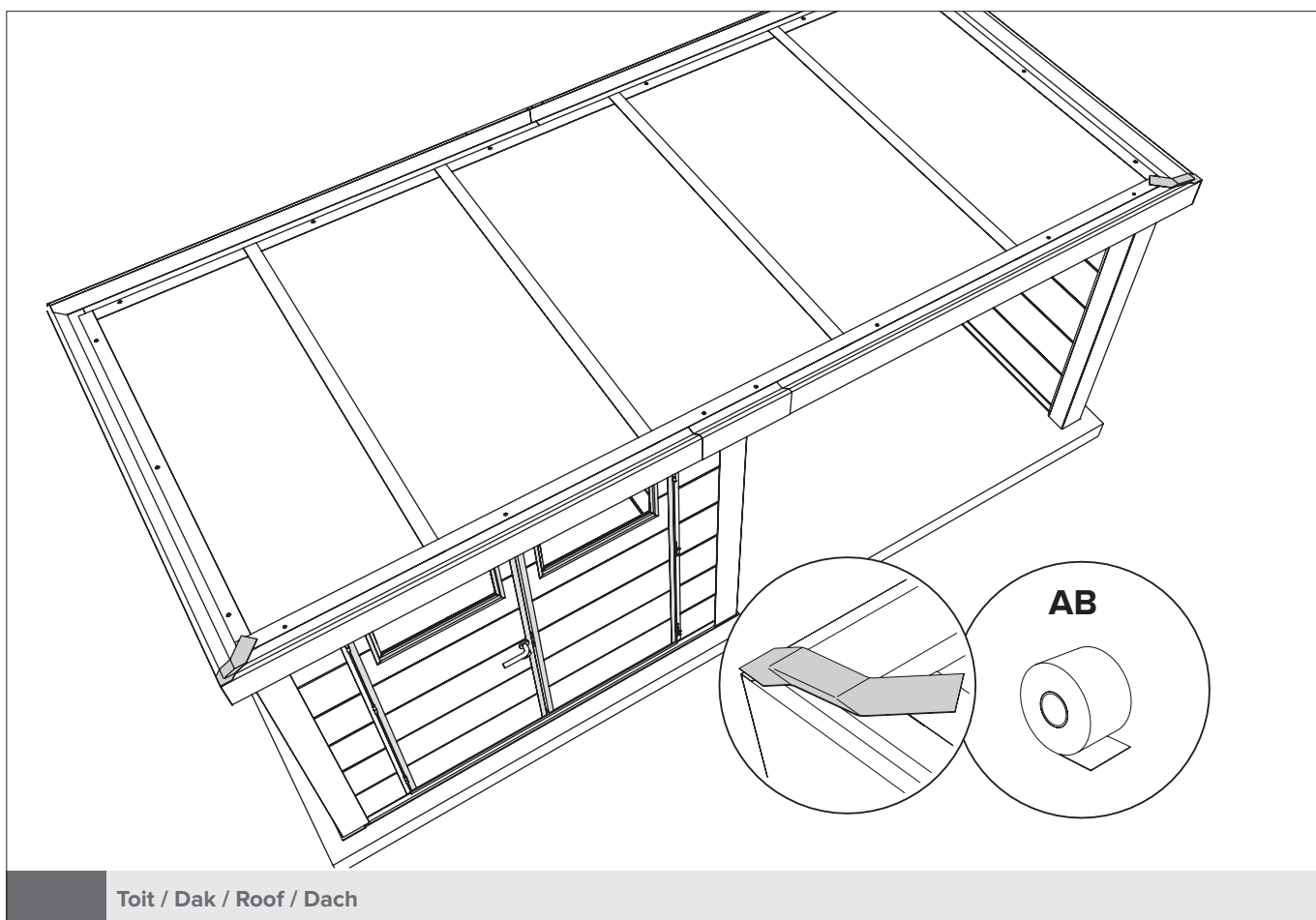
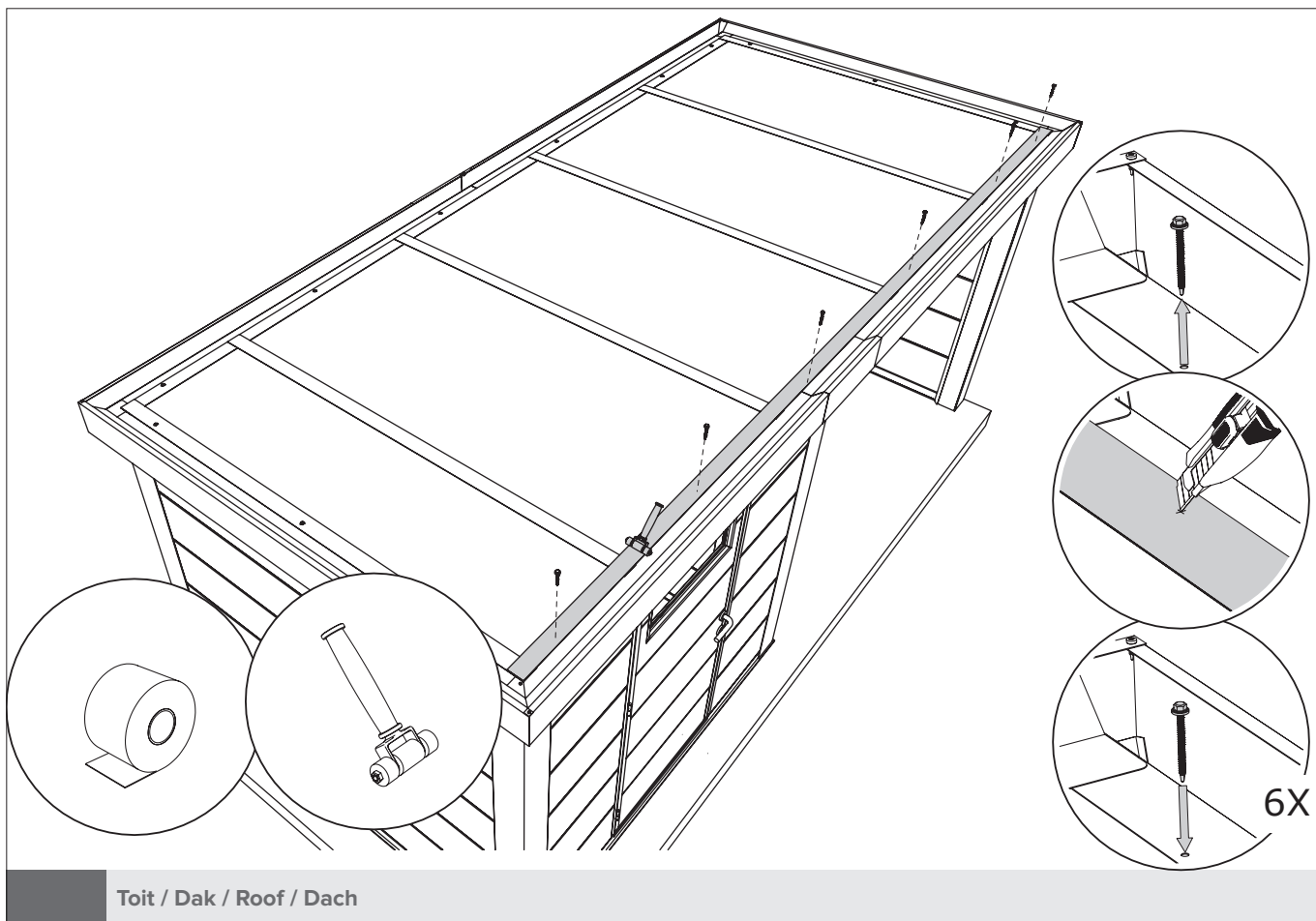

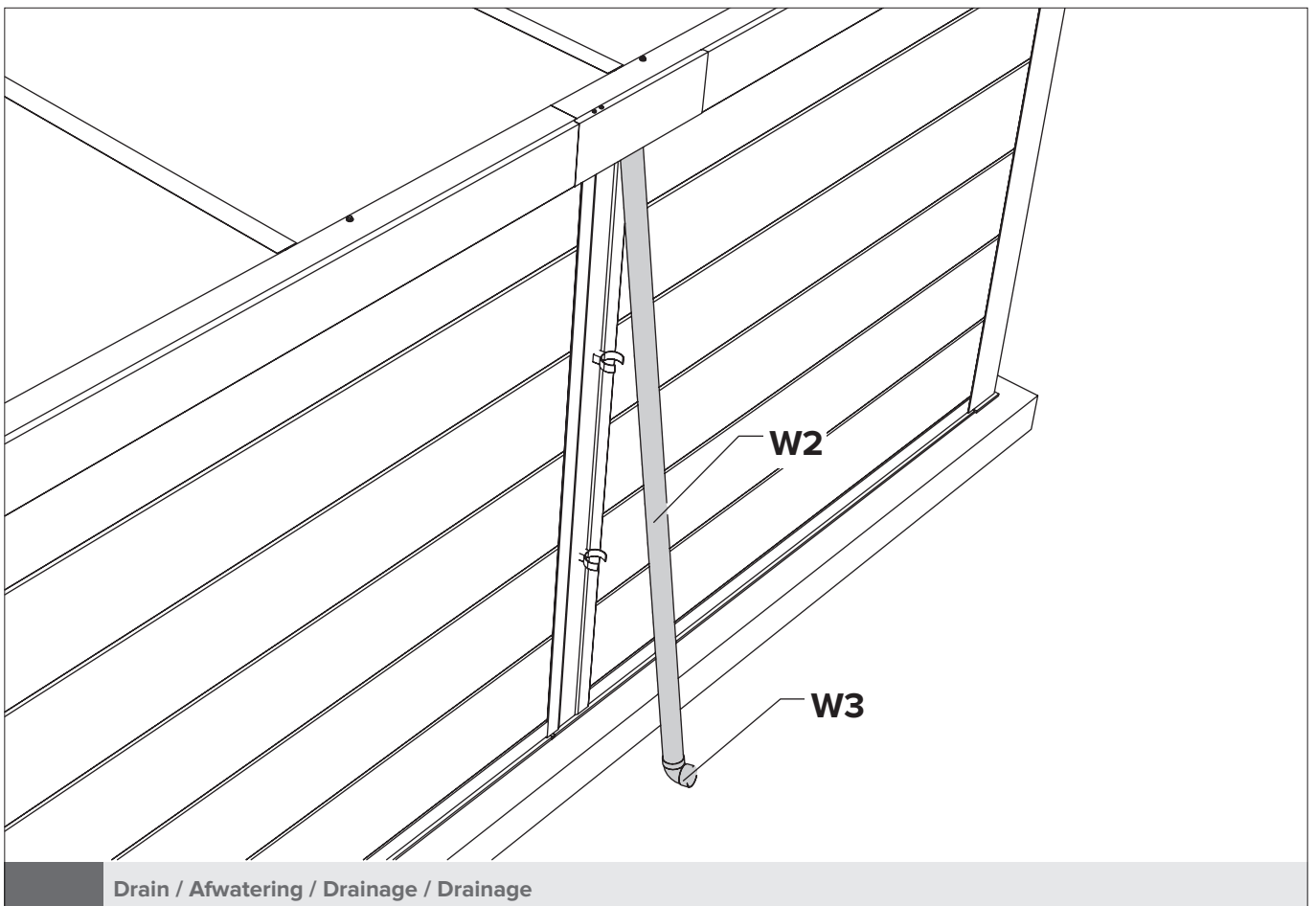
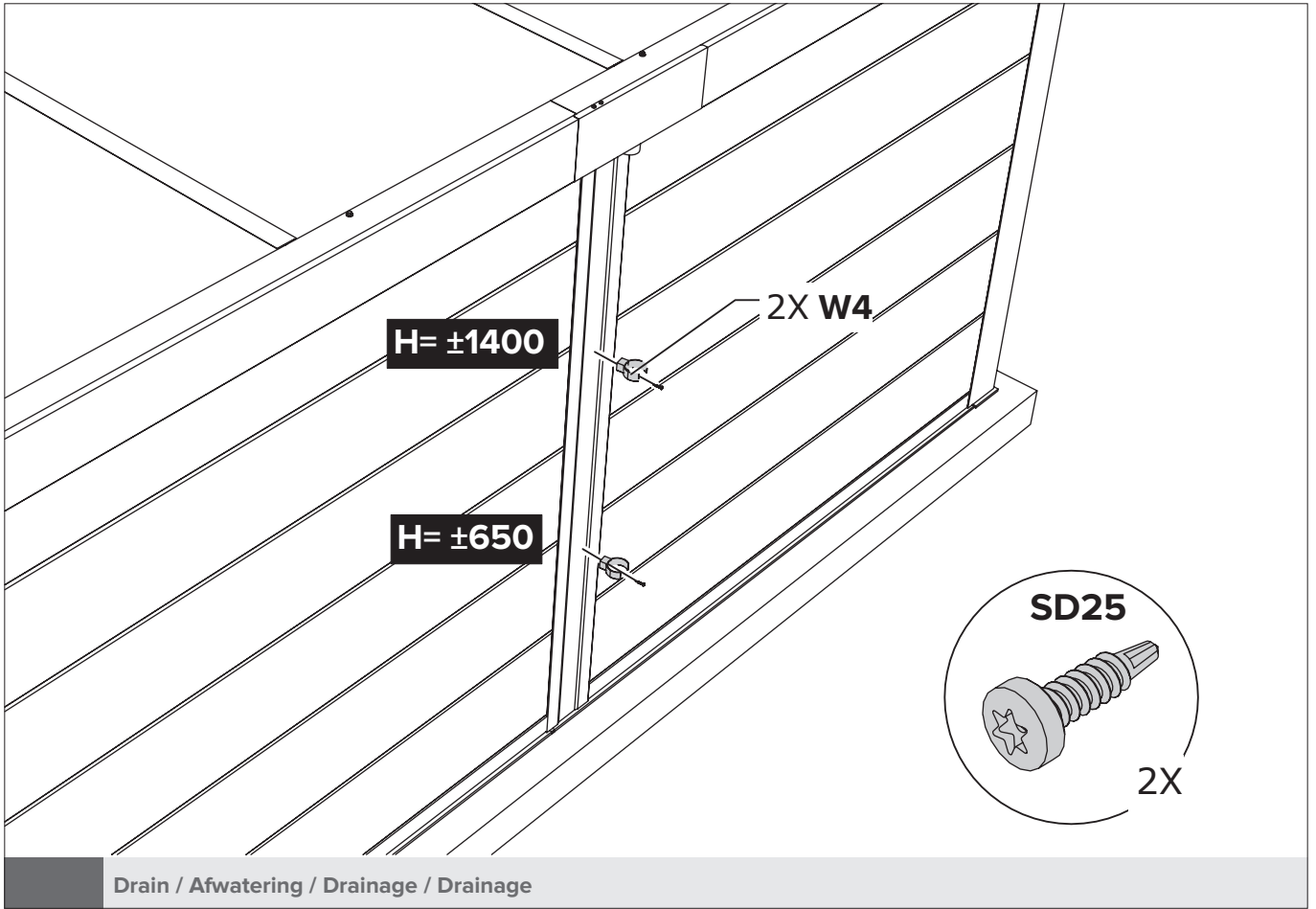

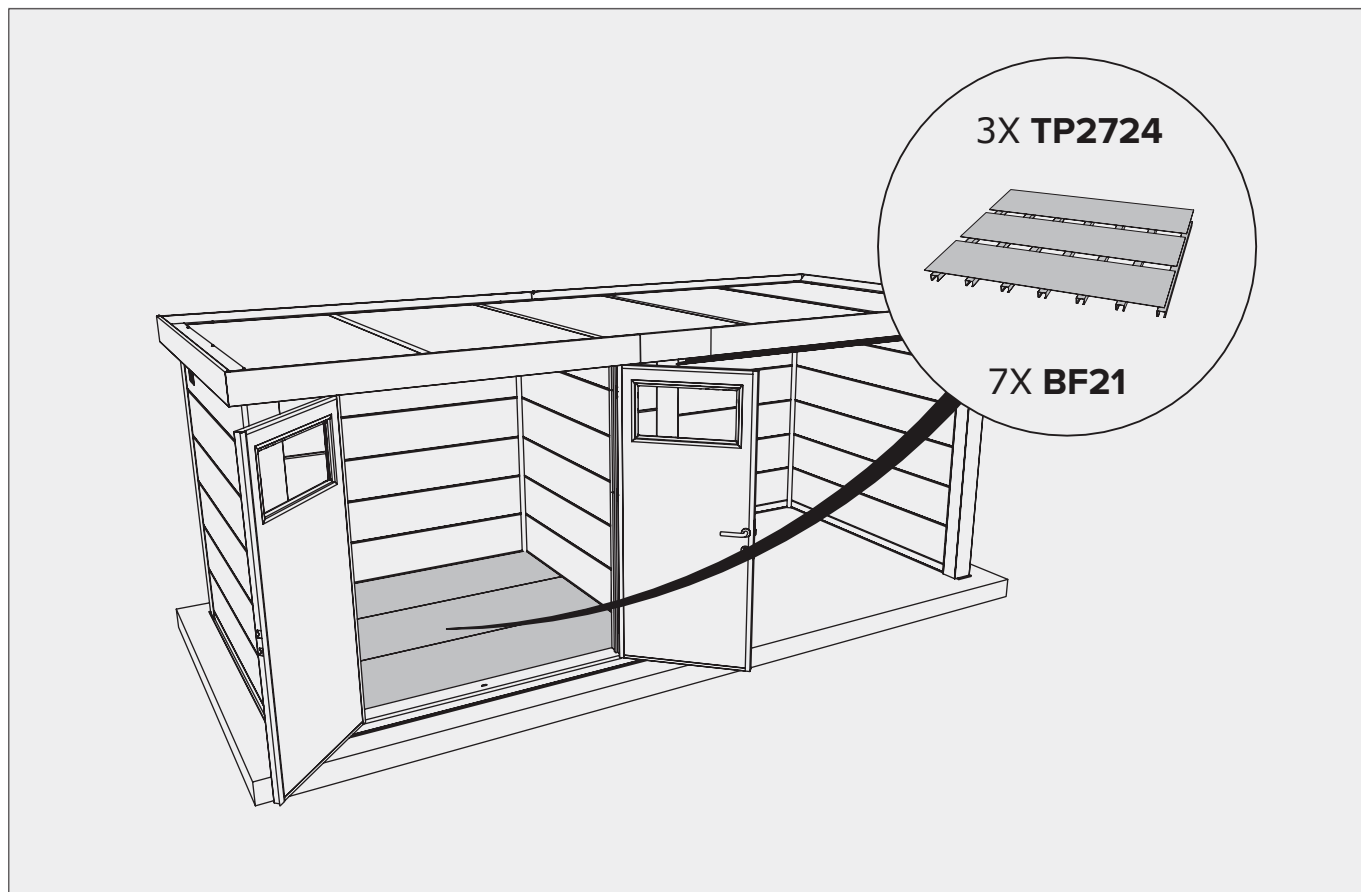

Sol / Vloer / Floor / Boden

Option / Optie / Option / Option

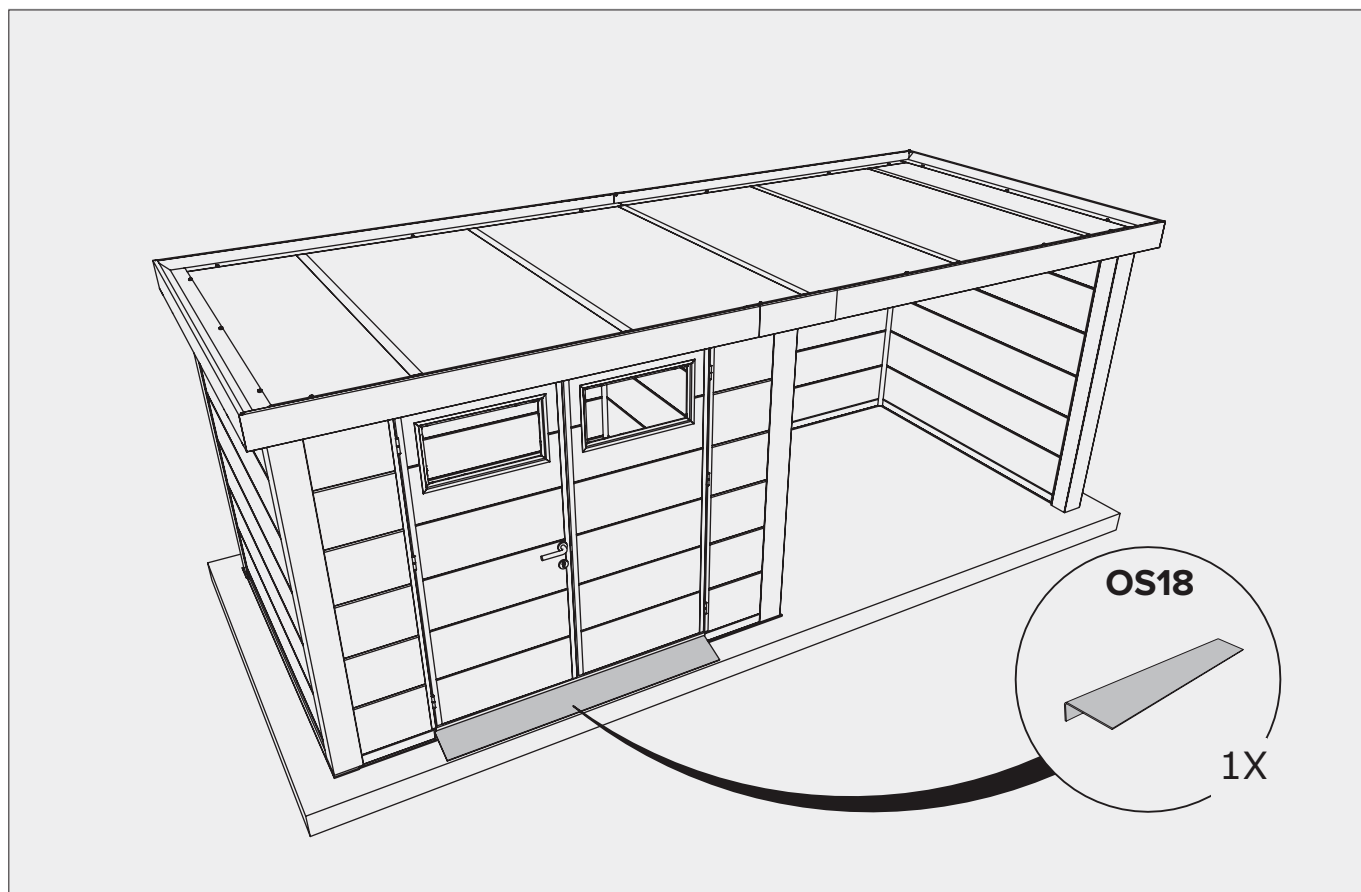

Rampe / Oprijplaat / Ramp / Rampe

Option / Optie / Option / Option

Beanstandungsformular

Bitte senden Sie dieses Formular per E-Mail an **kundendienst@finnhaus.de**

Bitte füllen Sie das Formular aus! (Bitte immer mit Fotonachweis)

Auftrags-, Lieferschein- oder Rechnungsnummer: _____

Hauskontrollnummer: _____

Haustyp/Modell: _____

Datum der Anlieferung: _____

Datum der Beanstandung: _____

Name des Händlers: _____

Ist das Haus von Finnhaus-Monteuren aufgebaut worden? Ja

Nein

Wenn nicht, durch wen wurde das Haus aufgebaut?

Name: _____

Straße/Hausnr.: _____

PLZ/Ort: _____

Telefon/Handy: _____

Wichtig

- Eindeutige Fotos der Beschädigung erstellen
- Fehlteile in der originalen Teile-/Stückliste mit Mengenangabe vermerken

Beanstandungsgrund

Wir bringen Urlaub in den Garten

Serviceleitfaden

Wir legen großen Wert auf die Qualität unserer Produkte.

Sollte es dennoch zu einer Beanstandung kommen, bitten wir Sie, diese grundsätzlich schriftlich per Mail zu melden und folgende Hinweise zu beachten:

Sollten Sie bei der Anlieferung erkennbare Beschädigungen feststellen, halten Sie diese bitte per Fotonachweis fest und lassen sich diese zwingend von dem Anlieferungsfahrer auf dem Frachtbrief/Lieferschein dokumentieren. Kommt erst beim Öffnen des Paketes beschädigte Ware zum Vorschein, erstellen Sie bitte ebenfalls einen Fotonachweis. Die Fotonachweise fügen Sie bitte der Meldung Ihrer Beanstandung bei.

Um Ihre Beanstandung reibungslos bearbeiten zu können, bitten wir um Ihre weitere Unterstützung:

- Geben Sie bitte die Auftragsnummer, Lieferscheinnummer oder Rechnungsnummer von Finnhaus Wolff an.
- An der Verpackung und/oder in den Unterlagen, die dem Paket beiliegen, finden Sie eine Hauskontrollnummer. Anhand dieser Nummer ist uns eine eindeutige Zuordnung möglich.
- Auf der im Paket beiliegenden Teileliste markieren Sie bitte die Positionen, die dem defekten Teil des Artikels entspricht. Bitte geben Sie dort auch die Stückzahl der defekten Teile an.
- Fügen Sie diese kommentierte Teileliste sowie die Hauskontrollnummer Ihrer Beanstandung hinzu.

Bitte senden Sie Ihre Mail an: kundendienst@finnhaus.de

Wir setzen uns in Kürze mit Ihnen in Verbindung.

Herzlichen Dank für Ihre Unterstützung!

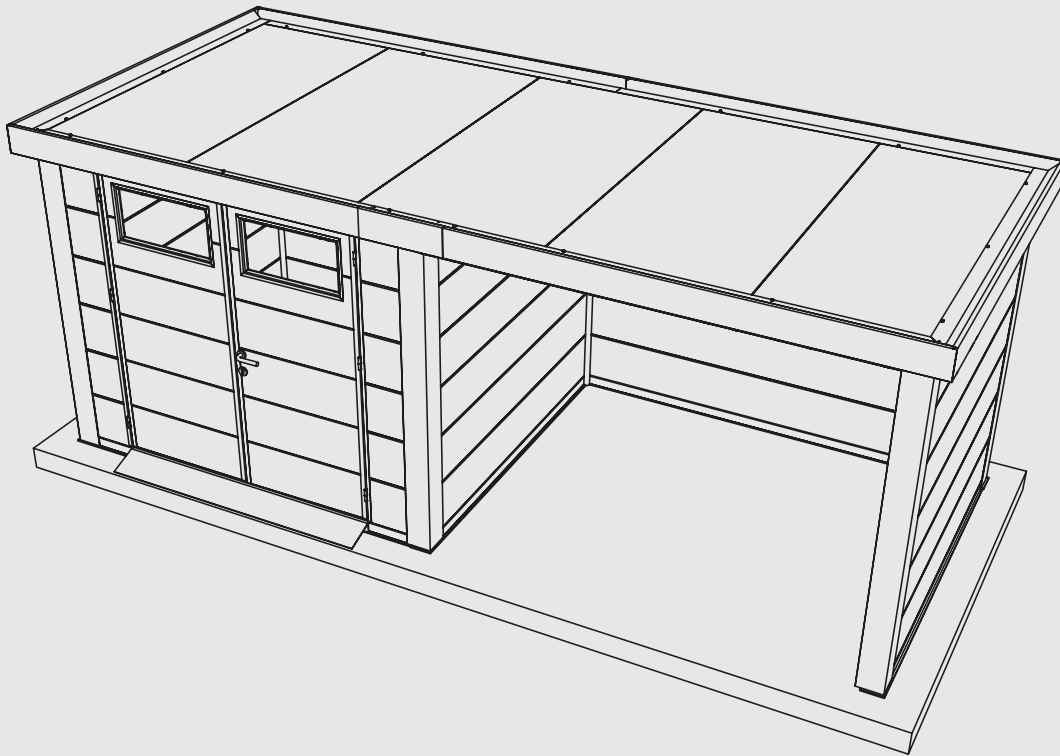

Merci de respecter l'environnement !

Pour une élimination correcte des déchets, il faut trier les différents matériaux conformément à la législation en vigueur. Droits d'auteur Telluria. Tous droits réservés. Aucun élément de la présente publication ne peut être reproduit ou diffusé sans l'autorisation écrite de Telluria. Les informations figurant dans la présente publication sont, pour des raisons techniques et/ou commerciales, sujettes à modification sans avis préalable. Telluria ne peut être tenue pour responsable des éventuels oublis et erreurs de la présente publication.

Draag zorg voor het milieu!

Voor een correcte afvalverwijdering moeten de verschillende materialen volgens de toepasselijke regelgeving worden gescheiden. Auteursrechten Telluria. Alle rechten voorbehouden. Niets in deze publicatie mag worden gereproduceerd of verdeeld zonder de schriftelijke toestemming van Telluria. De gegevens in deze publicatie zijn, omwille van technische en/of commerciële redenen, onderhevig aan wijziging zonder voorafgaande kennisgeving. Telluria is niet verantwoordelijk voor eventuele vergissingen of onjuistheden in deze publicatie.

Protect the environment!

To ensure waste is disposed of correctly, the different materials must be separated according to the applicable regulations. Copyright Telluria. All rights reserved. Nothing in this publication may be reproduced or distributed without written permission from Telluria. The information in this publication is subject to change for technical and/or commercial reasons at any time and without notice. Telluria is not responsible for any errors or inaccuracies in this publication.

Achten Sie auf die Umwelt!

Um eine ordnungsgemäße Entsorgung zu gewährleisten, müssen die verschiedenen Materialien entsprechend den geltenden Vorschriften getrennt werden. Copyright Telluria. Alle Rechte vorbehalten. Kein Teil dieser Publikation darf ohne schriftliche Genehmigung von Telluria vervielfältigt oder verbreitet werden. Aus technischen und/oder kommerziellen Gründen können sich die in dieser Publikation enthaltenen Informationen ohne vorherige Ankündigung ändern. Telluria ist nicht verantwortlich für Fehler oder Ungenauigkeiten in dieser Publikation.

Sie haben Fragen zu diesem Produkt:
Bitte beachten Sie dazu die Informationen
aus dem Serviceleitfaden!

Kostenlose deutschsprachige Service Hotline:
0032 800 - 11564
Montag - Freitag: 09:00 - 16:00 Uhr

Kundendienst-Mail:
eleganto-service@telluria.eu



Merci de respecter l'environnement !

Pour une élimination correcte des déchets, il faut trier les différents matériaux conformément à la législation en vigueur.
Droits d'auteur Telluria. Tous droits réservés. Aucun élément de la présente publication ne peut être reproduit ou diffusé sans l'autorisation écrite de Telluria. Les informations figurant dans la présente publication sont, pour des raisons techniques et/ou commerciales, sujettes à modification sans avis préalable.
Telluria ne peut être tenue pour responsable des éventuels oublis et erreurs de la présente publication.

Draag zorg voor het milieu!

Voor een correcte afvalverwijdering moeten de verschillende materialen volgens de toepasselijke regelgeving worden gescheiden.
Auteursrechten Telluria. Alle rechten voorbehouden. Niets in deze publicatie mag worden gereproduceerd of verdeeld zonder de schriftelijke toestemming van Telluria.
De gegevens in deze publicatie zijn, omwille van technische en/of commerciële redenen, onderhevig aan wijziging zonder voorafgaande kennisgeving.
Telluria is niet verantwoordelijk voor eventuele vergissingen of onjuistheden in deze publicatie.

Protect the environment!

To ensure waste is disposed of correctly, the different materials must be separated according to the applicable regulations.
Copyright Telluria. All rights reserved. Nothing in this publication may be reproduced or distributed without written permission from Telluria. The information in this publication is subject to change for technical and/or commercial reasons at any time and without notice.
Telluria is not responsible for any errors or inaccuracies in this publication.

Achten Sie auf die Umwelt!

Um eine ordnungsgemäße Entsorgung zu gewährleisten, müssen die verschiedenen Materialien entsprechend den geltenden Vorschriften getrennt werden.
Copyright Telluria. Alle Rechte vorbehalten. Kein Teil dieser Publikation darf ohne schriftliche Genehmigung von Telluria vervielfältigt oder verbreitet werden.
Aus technischen und/oder kommerziellen Gründen können sich die in dieser Publikation enthaltenen Informationen ohne vorherige Ankündigung ändern.
Telluria ist nicht verantwortlich für Fehler oder Ungenauigkeiten in dieser Publikation.



BC DESIGN
samen visualiseren

Manual by BC DESIGN bvba



FINNHAUS
WOLFF